



SPICER[®]
Off-Highway Products

Service Manual

Axle 213

ASM-0026E
June 2012

CONTENTS

INTRODUCTION	5
SPECIFICATIONS	6
DEFINITION OF VIEWPOINTS	6
DATA PLATE	6
CONVERSION TABLES	7
TORQUE SPECIFICATIONS	8
COARSE PITCH	8
FINE PITCH	8
WHEEL NUT TIGHTENING TORQUES	9
MAINTENANCE	10
MAINTENANCE POINTS	10
MAINTENANCE INTERVALS	11
ADJUSTMENT AND CHECKS	11
LUBRICANT & SEALANT SPECIFICATIONS	12
SAFETY PRECAUTIONS	13
AXLE BODY OIL CHANGE PROCEDURE	15
CHECKING BRAKE DISC WEAR	15
CHANGING OIL	16
DRAINING	16
FILLING	16
CHECKING WEAR AND REPLACING THE BRAKING DISCS	17
EXPLODED VIEW	17
DISASSEMBLY	18
ASSEMBLY	22
SPECIAL TOOLS	26
T1	26
T2	26
COMPLETE STEERING CASE	27
EXPLODED VIEW	27
DISASSEMBLY	28
ASSEMBLY	30
SERVICE BRAKE AND NEGATIVE PARKING BRAKE	33
EXPLODED VIEW	33
RELEASE	34
ADJUST	34
DISASSEMBLY	35
ASSEMBLY	38
SPECIAL TOOLS	43
T1	43
DOUBLE U-JOINT	45
EXPLODED VIEW	45
DISASSEMBLY	46
ASSEMBLY	47
SPECIAL TOOLS	48
T1	48
T2	48

PLANETARY REDUCTION GEAR	49
EXPLODED VIEW	49
DISASSEMBLY	50
ASSEMBLY	54
SPECIAL TOOLS	57
T1	57
T2	57
T3	58
T4	59
T5	60
T6	60
STEERING CYLINDER	61
EXPLODED VIEW	61
DISASSEMBLY	62
ASSEMBLY	65
SPECIAL TOOLS	71
T1	71
T2	71
DIFFERENTIAL UNIT	73
EXPLODED VIEW	73
DISASSEMBLY	74
INSTALL AND ADJUST	78
SPECIAL TOOLS	83
T1	83
T2	84
T3	84
BEVEL PINION	85
EXPLODED VIEW	85
DISASSEMBLY	86
INSTALL AND ADJUST	89
SPECIAL TOOLS	94
T1	94
T2	95
T3	96
T4	97
T5	98
HYDRAULIC DIFFERENTIAL UNIT	99
EXPLODED VIEW	99
DISASSEMBLY	100
ASSEMBLY	105
SPECIAL TOOLS	108
T1	108
T2	109
LIMITED SLIP DIFFERENTIAL UNIT 45%	111
EXPLODED VIEW	111
DISASSEMBLY	112
ASSEMBLY	114

INTRODUCTION

The efficiency and continued operation of mechanical units depend on constant, correct maintenance and also on efficient repair work, should there be a break-down or malfunction. The instructions contained in this manual have been based on a complete overhaul of the unit. However, it is up to the mechanic to decide whether or not it is necessary to assemble only individual components, when partial repair work is needed. The manual provides a quick and sure guide which, with the use of photographs and diagrams illustrating the various phases of the operations, allows accurate work to be performed. All the information needed for correct disassembly, checks and assembly of each individual component is set out below. In order to remove the differential unit from the vehicle, the manuals provided by the vehicle manufacturer should be consulted. In describing the following operations it is presumed that the unit has already been removed from the vehicle.

IMPORTANT: In order to facilitate work and protect both working surfaces and operators, it is advisable to use proper equipment such as: trestles or supporting benches, plastic or copper hammers, appropriate levers, pullers and specific spanners or wrenches. Before going on to disassemble the parts and drain the oil, it is best to thoroughly clean the unit, removing any encrusted or accumulated grease.

INTRODUCTORY REMARKS: All the disassembled mechanical units should be thoroughly cleaned with appropriate products and restored or replaced if damage, wear, cracking or seizing have occurred. In particular, thoroughly check the condition of all moving parts (bearings, gears, crown wheel and pinion, shafts) and sealing parts (o-rings, oil shields) which are subject to major stress and wear. In any case, it is advisable to replace the seals every time a component is overhauled or repaired. During assembly, the sealing rings must be lubricated on the sealing edge. In the case of the crown wheel and pinion, replacement of one component requires the replacement of the other one. During assembly, the prescribed pre-loading, backlash and torque of parts must be maintained.

CLASSIFICATION: This manual classifies units according to part numbers. For a correct interpretation, classification is indicated as follows:

- ▶▶ □ = up to the part number
- ▶▶ = from the part number on

When no classification is given, disassembly and assembly operations are the same for all versions.

SPECIFIC EQUIPMENT AND SPARE PARTS: The drawings of all specific tools required for maintenance and repair work can be found at the end of this manual ; spare parts may be ordered either from the vehicle manufacturer or directly from the Service Centers or Authorized Distributors of SPICER.

SPECIFICATIONS

DEFINITION OF VIEWPOINTS

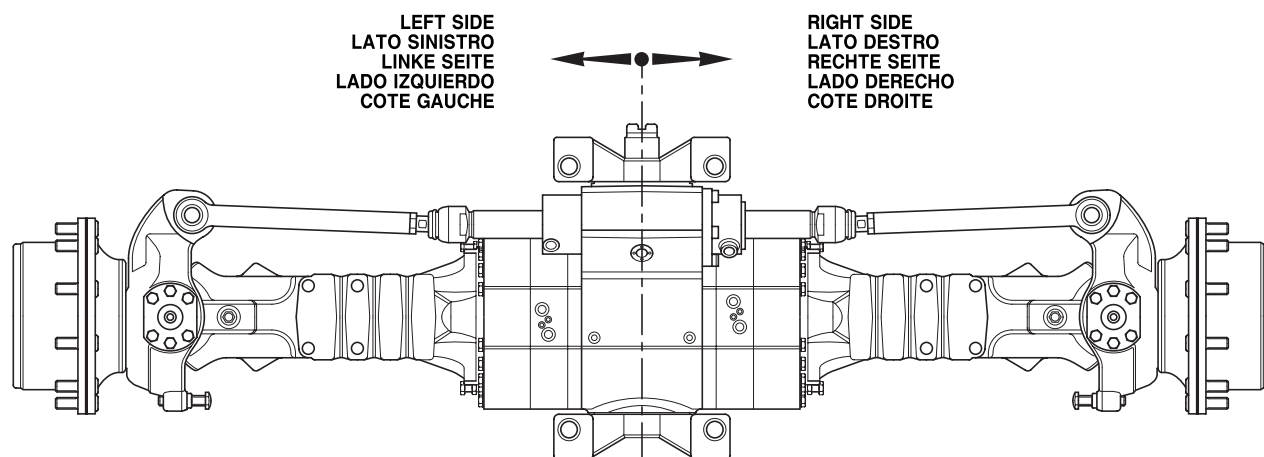

DATA PLATE

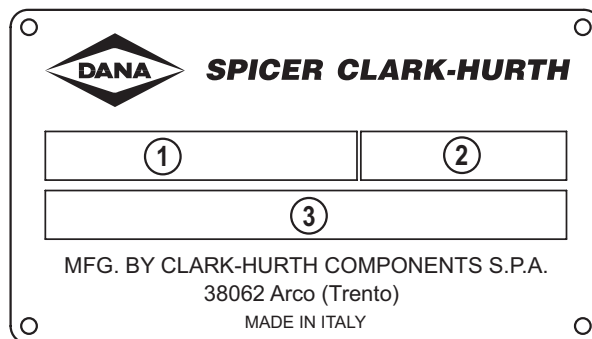

- 1 - Type and model unit - modification index
- 2 - Serial number
- 3 - Lubricant

CONVERSION TABLES

UNITS OF PRESSURE

1 ATM=1 BAR=10⁵ PA=14.4 PSI

UNIT OF WEIGHT

	N	daN	kN	kg	lbs
1N	1	0,1	0,001	0,102	0,225
1daN	10	1	0,01	1,02	2,25
1kN	1000	100	1	102	225
1kg	9,81	0,981	0,00981	1	2,205

UNITS OF TORQUE

	N·m	daN·m	kN·m	kg·m	lb·in
1N·m	1	0,1	0,001	0,102	8,854
1daN·m	10	1	0,01	1,02	88,54
1kN·m	1000	100	1	102	8854
1kg·m	9,81	0,981	0,00981	1	86,8
1 lb·in	0,1129	0,01129	0,0001129	0,01152	1

TORQUE SPECIFICATIONS

TORQUE SPECIFICATIONS

COARSE PITCH

SIZE OF BOLT	TYPE OF BOLT					
	8.8	8.8 + Loctite 270	10.9	10.9 + Loctite 270	12.9	12.9 + Loctite 270
M6 x 1 mm	9,5 – 10,5 N·m	10,5 – 11,5 N·m	14,3 – 15,7 N·m	15,2 – 16,8 N·m	16,2 – 17,8 N·m	18,1 – 20 N·m
M8 x 1,25 mm	23,8 – 26,2 N·m	25,6 – 28,4 N·m	34,2 – 37,8 N·m	36,7 – 40,5 N·m	39 – 43 N·m	43,7 – 48,3 N·m
M10 x 1,5 mm	48 – 53 N·m	52 – 58 N·m	68 – 75 N·m	73 – 81 N·m	80 – 88 N·m	88 – 97 N·m
M12 x 1,75 mm	82 – 91 N·m	90 – 100 N·m	116 – 128 N·m	126 – 139 N·m	139 – 153 N·m	152 – 168 N·m
M14 x 2 mm	129 – 143 N·m	143 – 158 N·m	182 – 202 N·m	200 – 221 N·m	221 – 244 N·m	238 – 263 N·m
M16 x 2 mm	200 – 221 N·m	219 – 242 N·m	283 – 312 N·m	309 – 341 N·m	337 – 373 N·m	371 – 410 N·m
M18 x 2,5 mm	276 – 305 N·m	299 – 331 N·m	390 – 431 N·m	428 – 473 N·m	466 – 515 N·m	509 – 562 N·m
M20 x 2,5 mm	390 – 431 N·m	428 – 473 N·m	553 – 611 N·m	603 – 667 N·m	660 – 730 N·m	722 – 798 N·m
M22 x 2,5 mm	523 – 578 N·m	575 – 635 N·m	746 – 824 N·m	817 – 903 N·m	893 – 987 N·m	974 – 1076 N·m
M24 x 3 mm	675 – 746 N·m	732 – 809 N·m	950 – 1050 N·m	1040 – 1150 N·m	1140 – 1260 N·m	1240 – 1370 N·m
M27 x 3 mm	998 – 1103 N·m	1088 – 1202 N·m	1411 – 1559 N·m	1539 – 1701 N·m	1710 – 1890 N·m	1838 – 2032 N·m
M30 x 3,5 mm	1378 – 1523 N·m	1473 – 1628 N·m	1914 – 2115 N·m	2085 – 2305 N·m	2280 – 2520 N·m	2494 – 2757 N·m

FINE PITCH

SIZE OF BOLT	TYPE OF BOLT					
	8.8	8.8 + Loctite 270	10.9	10.9 + Loctite 270	12.9	12.9 + Loctite 270
M8 x 1 mm	25,7 – 28,3 N·m	27,5 – 30,5 N·m	36,2 – 39,8 N·m	40 – 44 N·m	42,8 – 47,2 N·m	47,5 – 52,5 N·m
M10 x 1,25 mm	49,4 – 54,6 N·m	55,2 – 61 N·m	71,5 – 78,5 N·m	78 – 86 N·m	86 – 94 N·m	93 – 103 N·m
M12 x 1,25 mm	90 – 100 N·m	98 – 109 N·m	128 – 142 N·m	139 – 154 N·m	152 – 168 N·m	166 – 184 N·m
M12 x 1,5 mm	86 – 95 N·m	94 – 104 N·m	120 – 132 N·m	133 – 147 N·m	143 – 158 N·m	159 – 175 N·m
M14 x 1,5 mm	143 – 158 N·m	157 – 173 N·m	200 – 222 N·m	219 – 242 N·m	238 – 263 N·m	261 – 289 N·m
M16 x 1,5 mm	214 – 236 N·m	233 – 257 N·m	302 – 334 N·m	333 – 368 N·m	361 – 399 N·m	394 – 436 N·m
M18 x 1,5 mm	312 – 345 N·m	342 – 378 N·m	442 – 489 N·m	485 – 536 N·m	527 – 583 N·m	580 – 641 N·m
M20 x 1,5 mm	437 – 483 N·m	475 – 525 N·m	613 – 677 N·m	674 – 745 N·m	736 – 814 N·m	808 – 893 N·m
M22 x 1,5 mm	581 – 642 N·m	637 – 704 N·m	822 – 908 N·m	903 – 998 N·m	998 – 1103 N·m	1078 – 1191 N·m
M24 x 2 mm	741 – 819 N·m	808 – 893 N·m	1045 – 1155 N·m	1140 – 1260 N·m	1235 – 1365 N·m	1363 – 1507 N·m
M27 x 2 mm	1083 – 1197 N·m	1178 – 1302 N·m	1520 – 1680 N·m	1672 – 1848 N·m	1834 – 2027 N·m	2000 – 2210 N·m
M30 x 2 mm	1511 – 1670 N·m	1648 – 1822 N·m	2138 – 2363 N·m	2332 – 2577 N·m	2565 – 2835 N·m	2788 – 3082 N·m

TORQUE SPECIFICATIONS

WHEEL NUT TIGHTENING TORQUES

Wheel nut tightening torques recommended from rim's O.E.M. with reference to the quality of the rim's material.

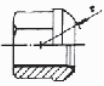
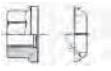
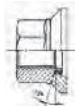
WHEEL NUT TIGHTENING TORQUES				
CHARACTERISTICS	ILLUSTRATION	WHEEL STUD THREAD	RECOMMENDED WHEEL NUTS TORQUE	
			RIM MATERIAL QUALITY	
			ST 37	**ST 52
WHEEL NUTS WITH INTEGRATE SPHERICAL COLLAR		M18 x 1,5 mm	330 N·m	460 N·m
		M20 x 1,5 mm	490 N·m	630 N·m
		M22 x 1,5 mm	630 N·m	740 N·m
FLAT COLLAR WHEEL NUTS WITH SEPARATE SPHERICAL LOCK WASHER		M18 x 1,5 mm	270 N·m	360 N·m
		M20 x 1,5 mm	360 N·m	450 N·m
		M22 x 1,5 mm	460 N·m	550 N·m
WHEEL NUTS WITH INTEGRATE SEAT CAPTIVE WASHER		M18 x 1,5 mm	260 N·m	360 N·m
		M20 x 1,5 mm	350 N·m	500 N·m
		M22 x 1,5 mm	450 N·m	650 N·m

****RIM MATERIAL ST 52 IS RECOMMENDED BY DANA ON AXLE APPLICATIONS. IT IS THE OPTIMUM MATERIAL FOR TIGHTENING THE RIM TO THE HUB.**

NOTE:

The wheel nut tightening torque is related only on nut thread and stud thread dry. (Without oil or any lubricant).

NOTE:

The wheel nut tightening torque takes into consideration not only the nut + stud characteristics, but also the quality of the rim material.

THE DANA OFFICIAL TIGHTENING TORQUE TABLE, THAT IS INCLUDED IN EACH SERVICE MANUAL, SHOWS THE TORQUE FIGURE RELATED TO THE BOLT CHARACTERISTIC ONLY.		
DANA OFFICIAL TIGHTENING TORQUE TABLE		
NUT MATERIAL QUALITY 8.8 & 10.9	STUD MATERIAL QUALITY 10.9	*ALLOW TIGHT TORQUE
M18 x 1,5 mm	M18 x 1,5 N·m	442 ÷ 489 N·m
M20 x 1,5 mm	M20 x 1,5 N·m	613 ÷ 677 N·m
M22 x 1,5 mm	M22 x 1,5 N·m	822 ÷ 908 N·m

***THE TORQUE FIGURE ON NUT AND STUD COUPLING MUST BE RELATED ON STUD MATERIAL QUALITY (DANA AXLES ARE 10.9 ONLY).**

MAINTENANCE

MAINTENANCE

MAINTENANCE POINTS

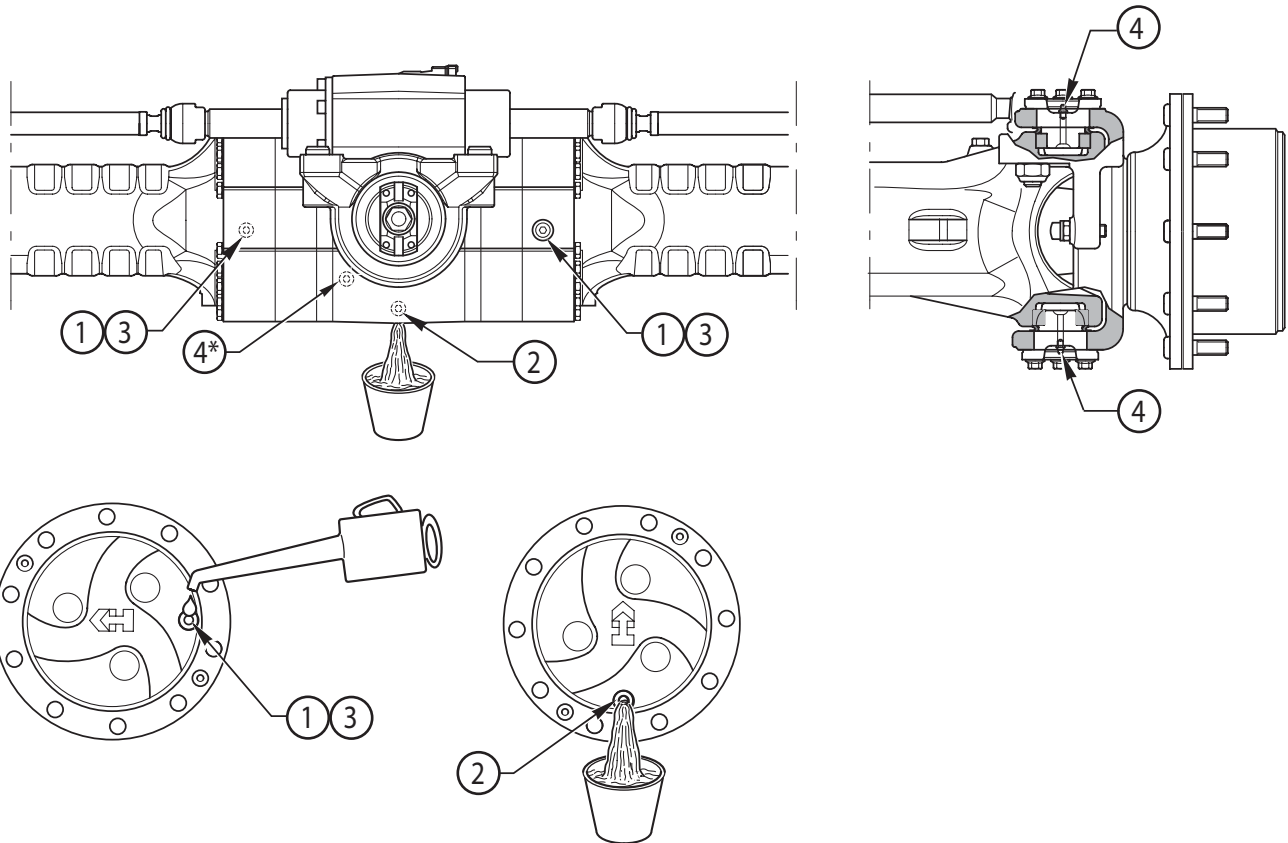

- 1 - Oil filling plug
- 2 - Oil draining plug
- 3 - Check level plug
- 4 - Grease zerk
- * Not present in all models

MAINTENANCE INTERVALS

OPERATION		FREQUENCY	LUBRICANTS
Check levels	Differential	Monthly	SAE85W90 (API GL4 - MIL L-2105) With additives for oil-bath brakes
	Planetary reduction	Every 200 hours	
Oil change	Differential	Every 800 hrs *	
	Planetary reduction	Every 1000 hrs *	
	Self-locking differential gear	Every 700 hrs	

Recommended to set axle's oil changes according to the machine maintenance intervals

If working in heavy conditions half intervals should be used

* Initially after 100 working hours

OPERATION	MEMBER	CONDITIONS	FREQUENCY	LUBRICANTS
Greasing	Articulations	Normal work	Monthly	NLGI 3 EP (ASTM D217: 220 - 250)
		Severe duty	Weekly	

ADJUSTMENT AND CHECKS

UNIT	OPERATION	FREQUENCY	SERVICE BRAKE CIRCUIT
Negative brake	Adjustment	Every 1000 hours*	Only for mineral oil use e.g. ATF Dexron II. Make sure that master cylinder seals are suitable for mineral oil.
Service brake	Adjustment	Every 500 hours	
Wheel nuts	Tightening	Every 200 hours**	

* Initially after 100 working hours

** Initially after 10 working hours

MAINTENANCE

LUBRICANT & SEALANT SPECIFICATIONS

1 - Locking, sealing and lubricating materials referred to in this manual are the same used in the shop-floor.

2 - The table below gives an account of the typical applications of each single material, in order to facilitate replacement with similar products marketed by different brand names with different trade marks.

LOCTITE 242

Anaerobic product apt to prevent the loosening of screws, nuts and plugs. Used for medium-strength locking. Before using it, completely remove any lubricant by using the specific activator.

LOCTITE 243

The oleocompatible alternative to 242. Does not require the activation of lubricated surfaces.

LOCTITE 270

Anaerobic product for very-high strength locking of screws and nuts. Before using it, completely remove any lubricant by using the specific activator.

To remove parts, it may be necessary to heat them at 80° C approximately.

LOCTITE 275

Anaerobic product suitable for high-strength locking and sealing of large threaded parts, bolts and stud bolts, for pipe sealing and for protecting parts against tampering; suitable for sealing coupling surfaces with a maximum diametrical clearance of 0.25 mm.

LOCTITE 510

Anaerobic product for the hermetic sealing of flanged units and screw holes communicating with fluids. Can seal clearances between flanges up to 0.2 mm.

LOCTITE 577

Quick anaerobic sealant for sealing threaded portions of conical or cylindrical unions up to M80. Before using it, remove any lubricant with the specific activator. After polymerisation, disassembly may result rather difficult, so heating may be necessary for larger diameters.

LOCTITE 638

Anaerobic adhesive for fast and high-strength gluing of cylindrical metal joints (hub on shaft). Can glue together parts with clearance ranging between 0.1 and 0.25 mm.

LOCTITE 648

Anaerobic adhesive for fast and medium-strength gluing of cylindrical metal joints (hub on shaft). Can glue together parts with radial clearance below 0.1 mm.

AREXONS (REPOSITIONABLE JOINTING COMPOUND FOR SEALS)

Solvent-based sealing compound for elastic seals, drying through evaporation. Used for sealing the outer diameter of sealing rings for rotating shafts with outer metal reinforcement.

SILICONE

Semi-fluid adhesive material used for sealing and filling and to protect components from environmental and physical elements. Polymerises with non-corrosive dampness.

TECNO LUBE/101 (SILICONE-BASED GREASE)

Highly adhesive synthetic grease, with silicone compounds added.

Applied to adjustment screws with hole communicating with oil-type fluids.

Used when frequent adjusting is required.

MOLIKOTE (DOW CORNING)

Lubricating compound containing molybdenum disulphide, used to lubricate articulation pins and to prevent sticking and oxidation of parts that are not lubricated on a regular basis.

(LITHIUM-BASED) GREASE

Applied to bearings, sliding parts and used to lubricate seals or parts during assembly.

SAFETY PRECAUTIONS

- 1** - During all operations described in this manual, the axle should be fastened onto a trestle, while the other parts mentioned should rest on supporting benches.
- 2** - When removing one of the arms, an anti-tilting safety trestle should be placed under the other arm.
- 3** - When working on an arm that is fitted on the machine, make sure that the supporting trestles are correctly positioned and that the machine is locked lengthways.
- 4** - Do not admit any other person inside the work area; mark off the area, hang warning signs and remove the ignition key from the machine.
- 5** - Use only clean, quality tools; discard all worn, damaged, lowquality or improvised wrenches and tools. Ensure that all torque wrenches have been checked and calibrated.
- 6** - Always wear gloves and non-slip rubber shoes when performing repair work.
- 7** - Should you stain a surface with oil, remove marks straight away.
- 8** - Dispose of all lubricants, seals, rags and solvents once work has been completed. Treat them as special waste and dispose of them according to the relative law provisions obtaining in the country where the axles are being overhauled.
- 9** - Make sure that only weak solvents are used for cleaning purposes; avoid using turpentine, dilutants and toluol, xylolbased or similar solvents; use light solvents such as Kerosene, mineral spirits or water-based, environment friendly solvents.
- 10** - For the sake of clarity, the parts that do not normally need to be removed have not been reproduced in some of the diagrams.
- 11** - After repair work has been completed, accurately touch up any coated part that may have been damaged.
- 12** - Follow all safety instructions in the Original Equipment Manufacturer (OEM) manual that came with the vehicle.

AXLE BODY OIL CHANGE PROCEDURE

CHECKING BRAKE DISC WEAR

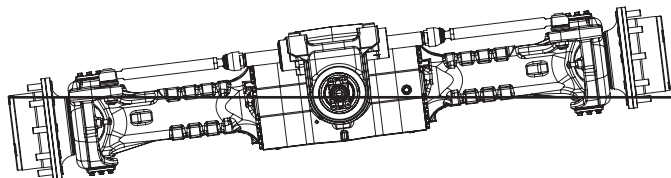
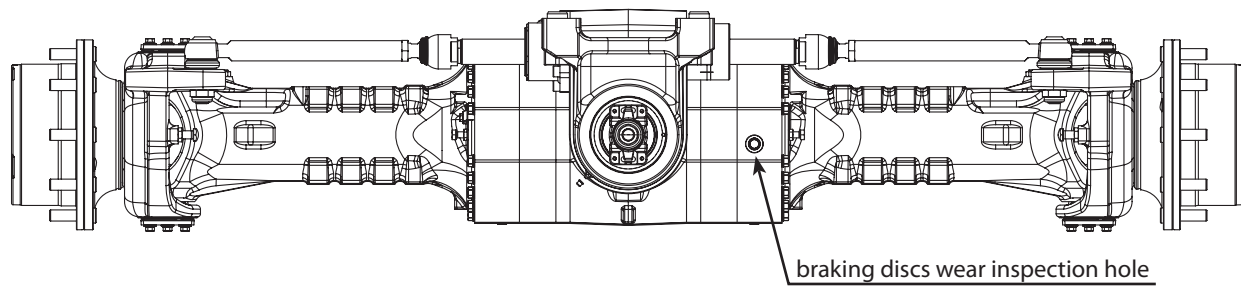

⚠ CAUTION

Brake disc wear can be checked in two ways as follows:

- 1 - without draining the oil, tilt the axle so that oil does not leak from the inspection hole (approximately 8°)
- 2 - drain the oil from the axle and then check

CHECKING BRAKE DISC WEAR

CHANGING OIL

WARNING

Hot oil components can cause injury. Avoid skin contact.

NOTE:

Make sure all fluids are contained during inspection, maintenance, tests, adjustment and repair of the product. Prepare a suitable container to collect the fluid before removing any component containing fluids. Dispose of all fluids following legal and local regulations.

DRAINING

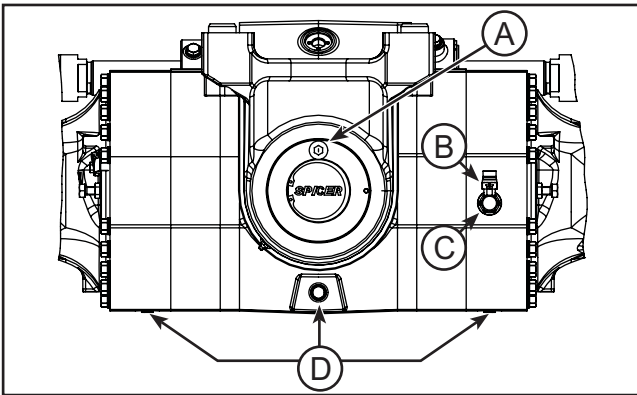

- 1 - Before draining the oil, remove the level plugs (A) to release any internal pressure.

FOR MODELS WITH OIL FITTING ELBOW:

- 2 - Remove the oil fitting elbow (B).

NOTE:

DO NOT REMOVE THE ELBOW FITTING (C).

FOR STANDARD MODELS: REMOVE THE OIL FITTING PLUG IN POSITION (C).

- 3 - To drain the oil from the central part of the axle, slacken and remove the drain plugs (D).

FILLING

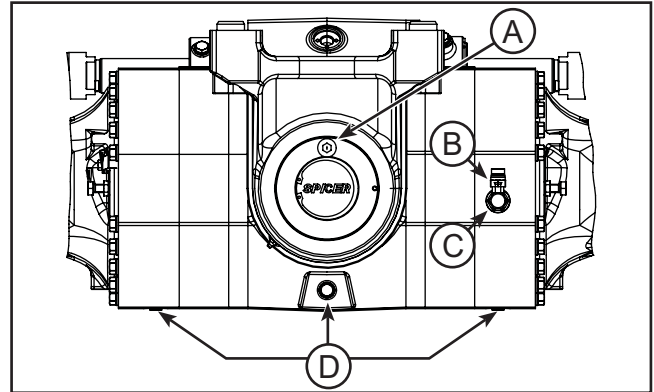

- 1 - Tighten the drain plugs (D) to a torque of 50 - 60 N·m.
- 2 - Fill up the axle body (A) with new oil. When filling the axle with oil, WAIT FOR 15 MINUTES for the oil to flow through the differential and the brakes into the axle arms.
- 3 - Check carefully that the oil is at the correct level and top up if necessary.

NOTE:

On models with oil fitting elbow, see the illustration below for the fill level and then tighten the oil fitting elbow to 50 - 70 N·m.

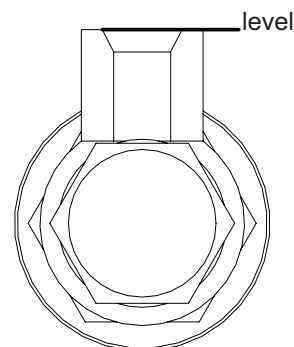

- 4 - Fit the oil plug (A) and tighten to a torque of 50 - 60 N·m.

CHECKING WEAR AND REPLACING THE BRAKING DISCS

EXPLODED VIEW

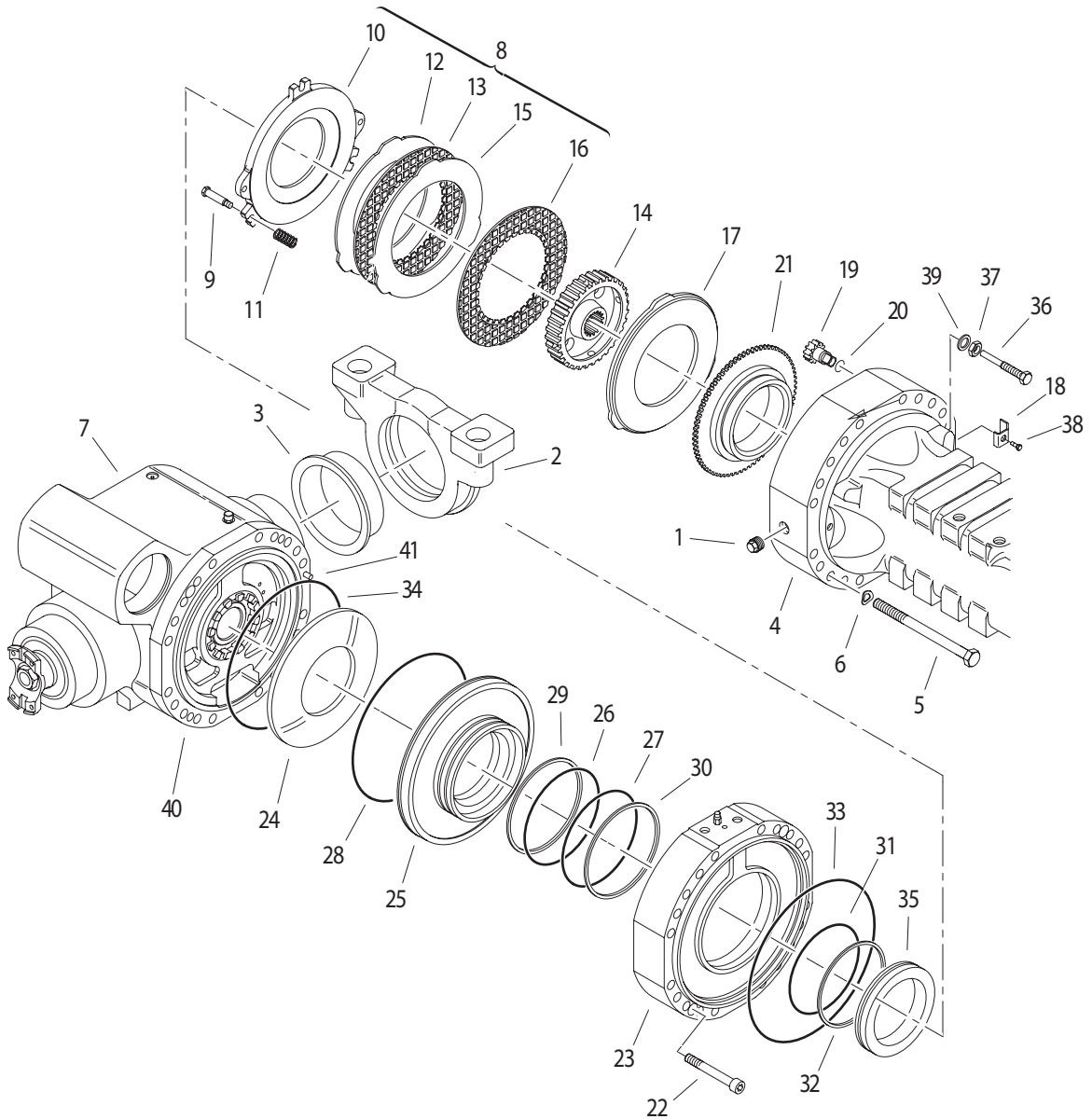

DISASSEMBLY

DISASSEMBLY

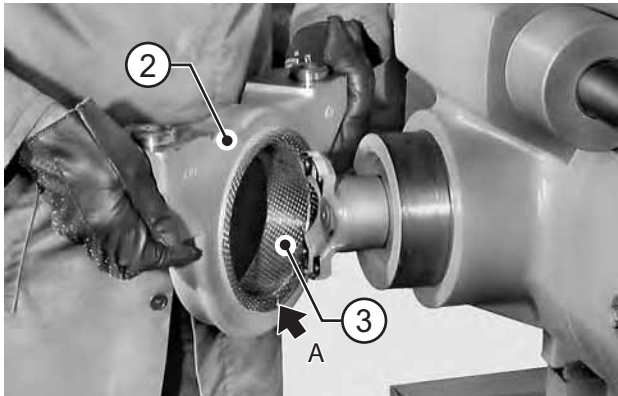

FIGURE 1: REPLACING DISCS
Remove the rocking support (2) from non-drive end.

NOTE:

If bushing (3) will be replaced because it is worn, write down direction of installation of joint split "A".

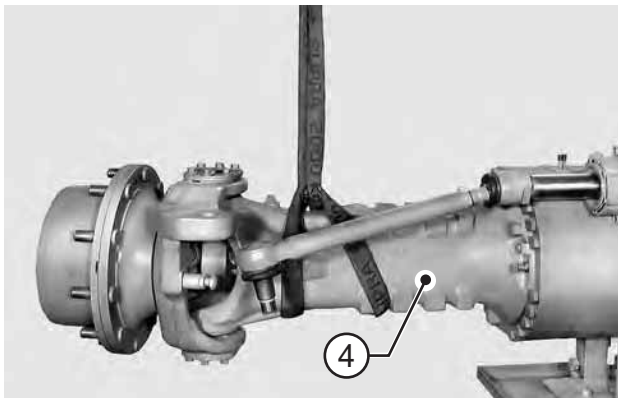

FIGURE 2: Disconnect steering bar pivots from the steering cases (See STEERING CYLINDER p. 61). Sling arm (4) to be removed and slightly tighten the sling rope.

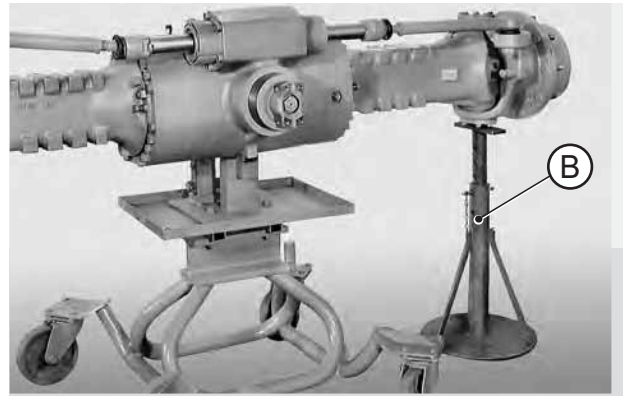

FIGURE 3: If axle is positioned on an overhaul bench, place a safety anti-tilting stand "B" under the arm that remains connected and block wheels, if any.

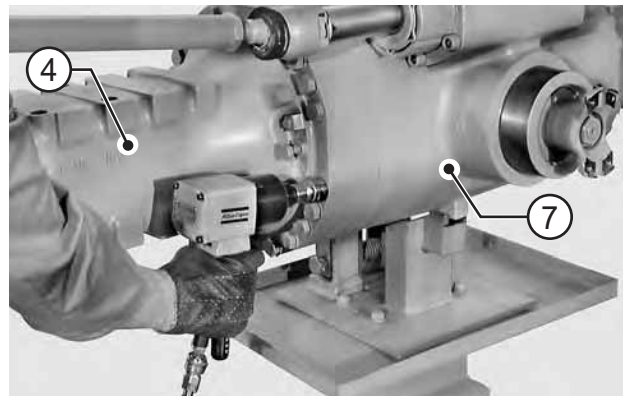

FIGURE 4: Loosen and remove the screws (5) and washers (6) that fix the arm (4) to the main body (7).

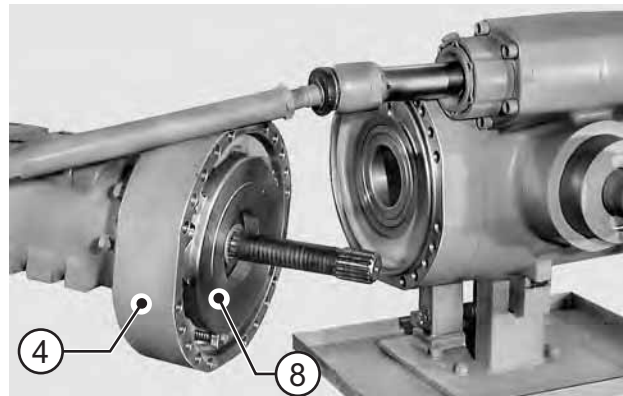

FIGURE 5: Remove arm (4) along with brake discs pack (8). Lay the arm on a workbench.

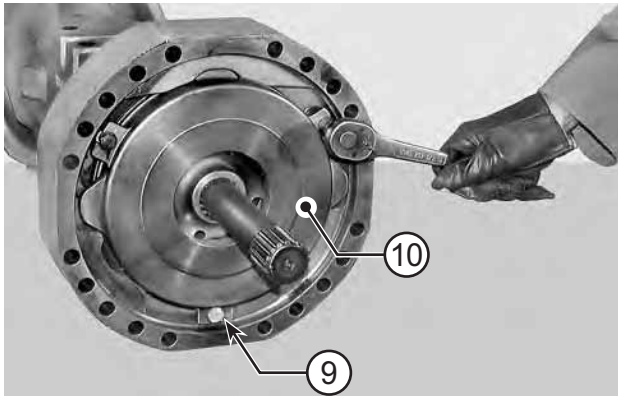

FIGURE 6: Loosen check and guide screws (9) of thrust disc (10).

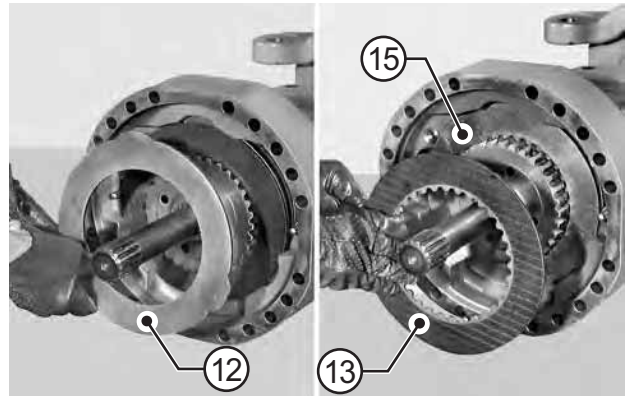

FIGURE 8: Remove in sequence: first intermediate disc (12), friction disc (13), and second intermediate disc (15).

⚠ CAUTION

Loosen screws (9) in several stages, sequentially and slowly.

⚠ CAUTION

Check friction disc thickness; if thickness is 5 mm or less, replace discs on both sides.

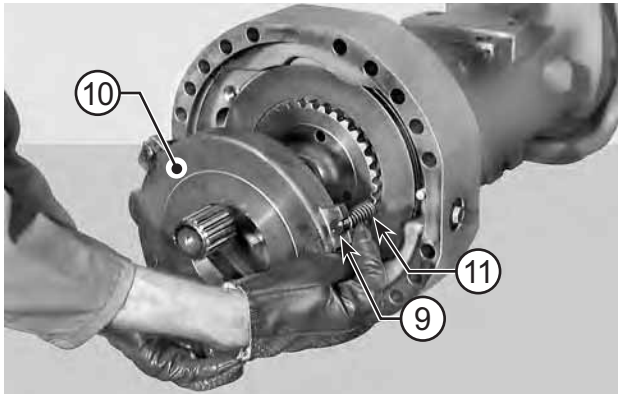

FIGURE 7: Remove the thrust disc (10) along with screws (9) and springs (11).

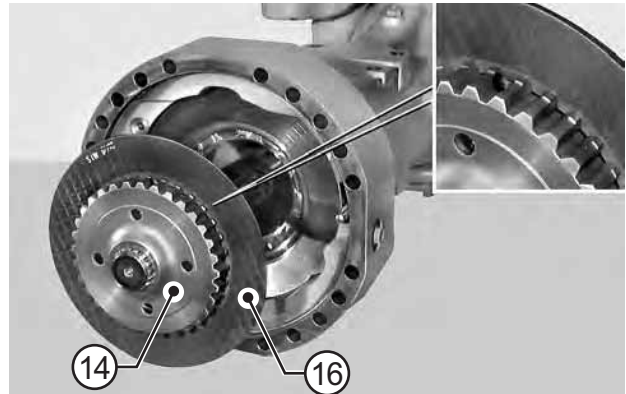

FIGURE 9: Remove both coupling (14) and friction disc (16) at the same time.

📌 NOTE:

Write down direction of installation.

⚠ CAUTION

Write down direction of installation of coupling (14) in relation to brake disc (16).

DISASSEMBLY

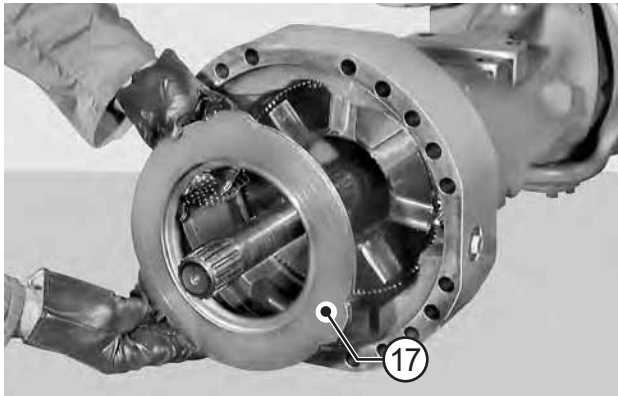

FIGURE 10: Remove end counter plate (17).

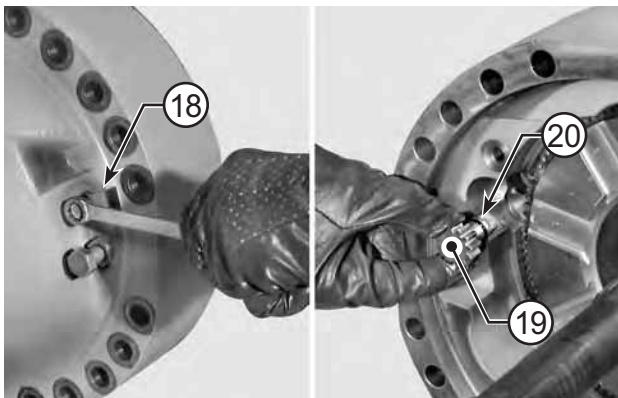

FIGURE 11: Only if necessary, remove catch (18) and pinion (19) for the brake adjustment and replace the o-ring (20).

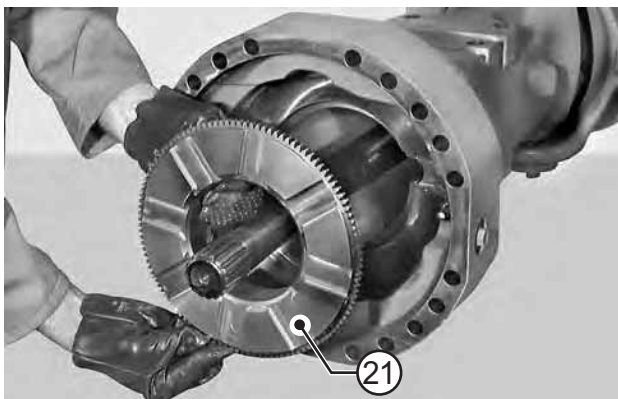

FIGURE 12: Only if necessary, remove ring (21) for the brake adjustment.

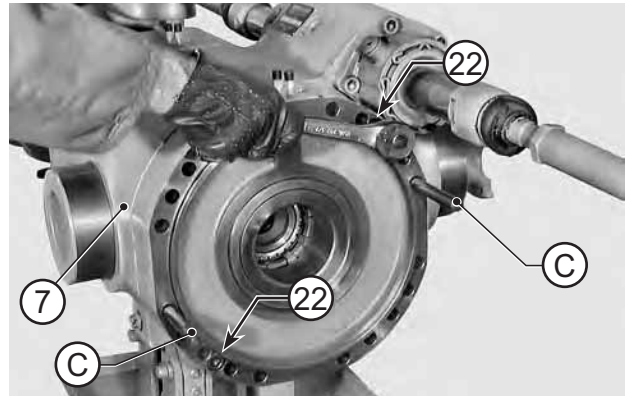

FIGURE 13: REPLACING BRAKE SEALS

Tighten two safety studs "C" in two opposite holes on the main body (7). Loosen screws (22) in an alternate manner until the thrust exerted by the Belleville washer is eliminated, then remove the screws.

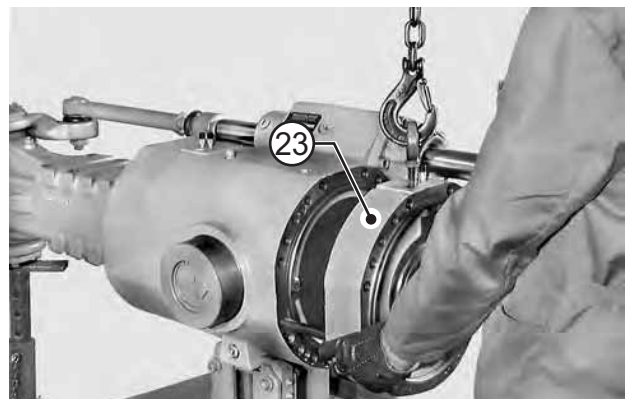

FIGURE 14: Tighten an eye-bolt in either of the connection holes of the braking system and connect the eye-bolt to a hoist. Extract screws "C" and remove brake cylinder (23).

NOTE:

Support the Belleville washers (24), as they may fall.

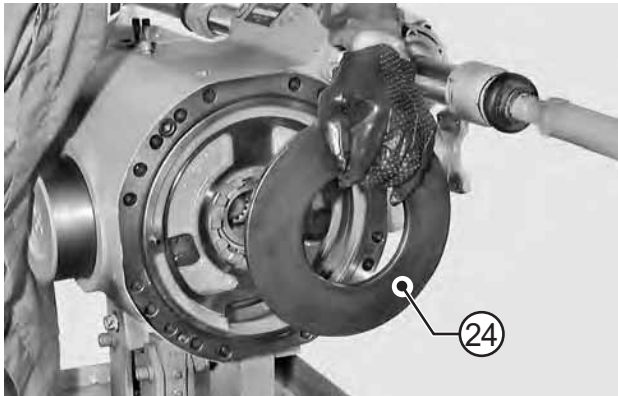

FIGURE 15: Remove Belleville washer (24) from the main body (7).

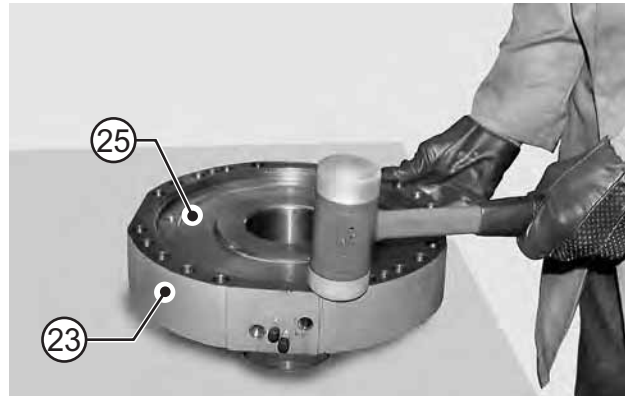

FIGURE 18: Hammer the brake cylinder (23) with a plastic hammer until the negative brake piston (25) comes out.

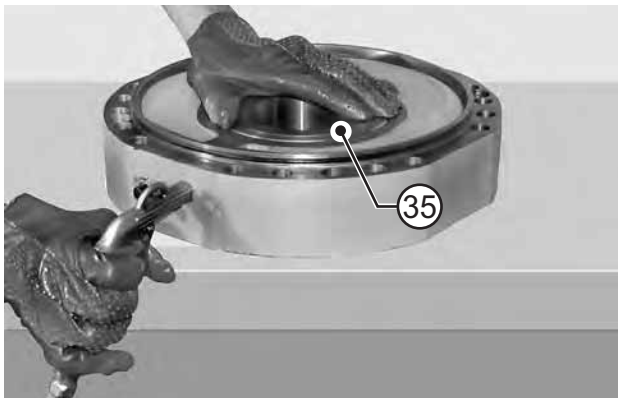

FIGURE 16: Carefully introduce low pressure compressed air through the hole of service brake and eject piston (35).

NOTE:

Tap around the whole rim and replace seals at each disassembly.

NOTE:

Replace seals at each disassembly.

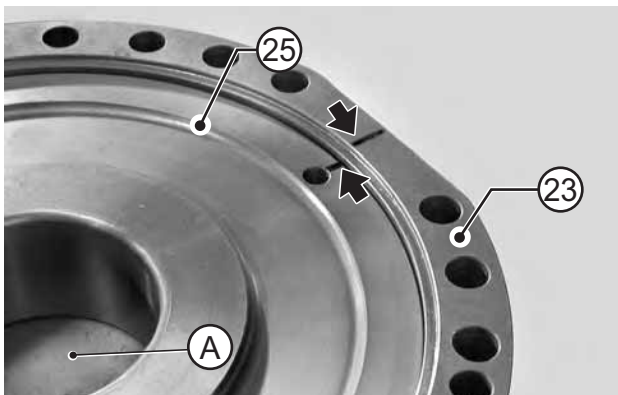

FIGURE 17: Turn assembly (23) over and place it on a support "A" 125 x 50 mm made of tender material (aluminium or copper). Make positional marks across brake cylinder (23) and piston (25) to mark the position of the pin hole.

ASSEMBLY

ASSEMBLY

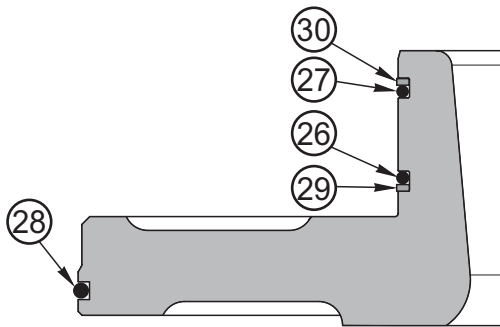

FIGURE 19: Thoroughly clean negative brake piston as well as beds and seal seats. Replace o-ring seals (26), (27) and (28) as well as anti-extrusion rings (29) and (30), keeping to assembling positions.

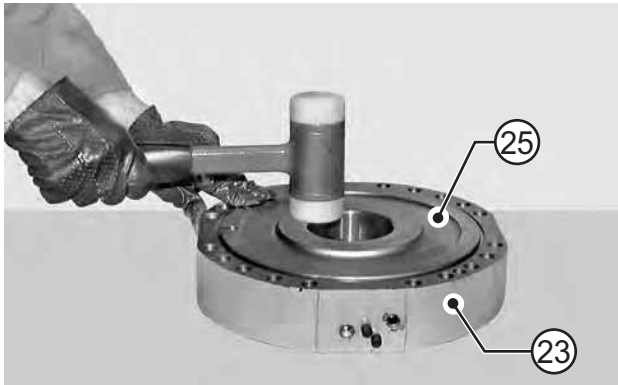

FIGURE 20: Lubricate seals (26), (27) and (28) with oil and, using a plastic hammer, install piston (25) into brake cylinder (23).

CAUTION

- 1 - Hammer around the whole rim
- 2 - Check match marks of guide pin hole

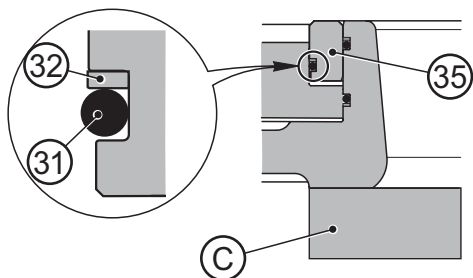

FIGURE 21: Turn the kit over and lay it on a support "C". Clean piston (35) of service brake as well as bed and seal seat. Replace o-ring (31) and anti-extrusion ring (32) observing assembling position.

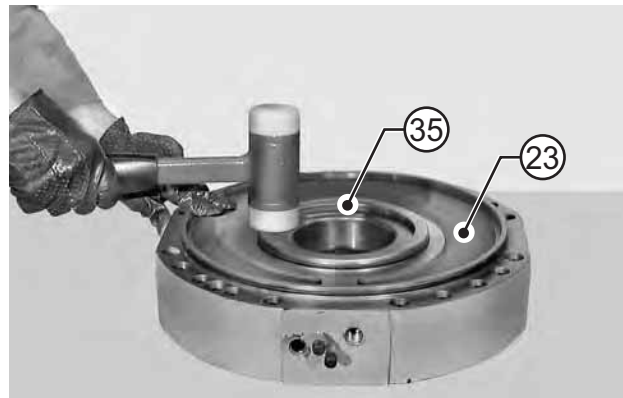

FIGURE 22: Lubricate seal (31) with oil and install piston (35) in brake cylinder (25) using a plastic hammer.

CAUTION

- 1 - Hammer around the whole rim
- 2 - Check direction of installation

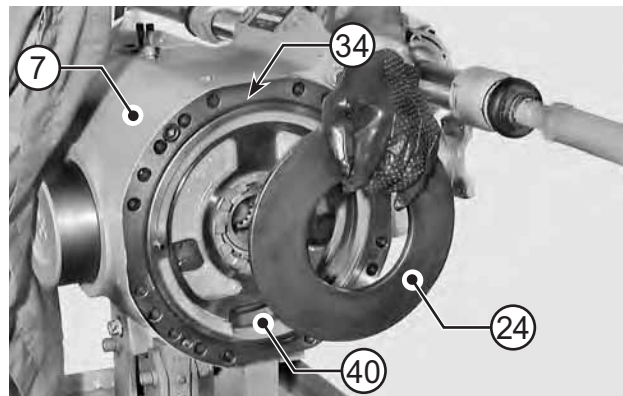

FIGURE 23: Coat the outer rim of the Belleville washer (24) with grease and place it in the appropriate seat in the intermediate cover. Install a new o-ring (34) in the intermediate cover.

CAUTION

The outer rim of the Belleville washer must be centered in the intermediate cover (40).

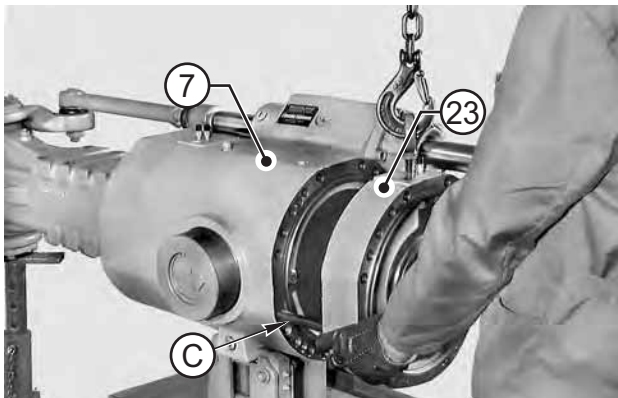

FIGURE 24: Hoist the brake cylinder (23) and position it opposite the main body (7). Tighten two safety studs "C" in the main body (7) and disconnect from the hoist.

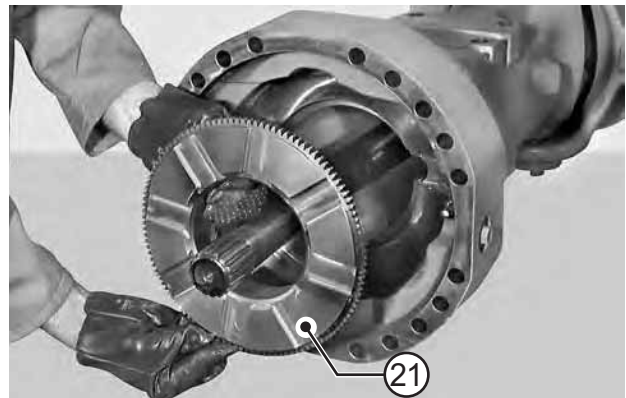

FIGURE 27: Only if adjustment ring has been removed, tighten the ring (21) for the brake adjustment.

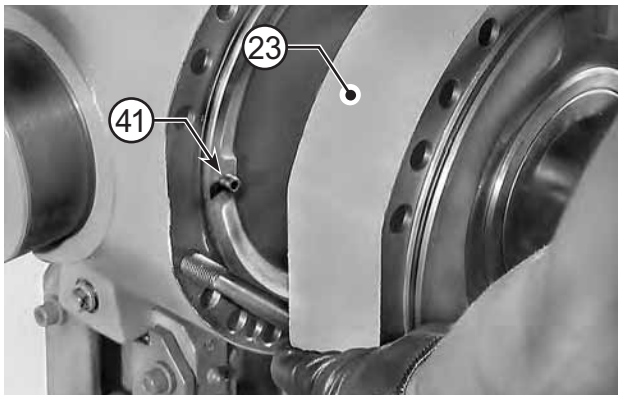

FIGURE 25: Push cylinder unit (23) to stop and check that the anti-rotation pin (41) is centered.

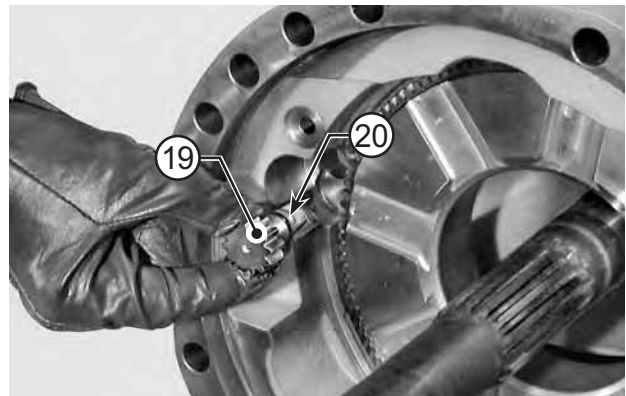

FIGURE 28: Only if pinion has been removed, install pinion (19) with new o-ring (20) coated with grease.

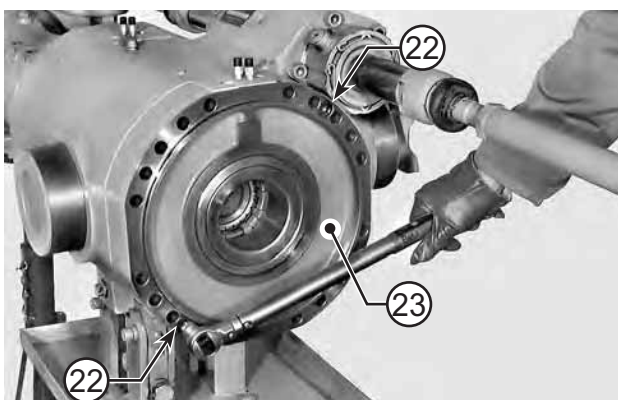

FIGURE 26: Attach cylinder (23) with screws (22) tightened and coated with Loctite 242 to a torque of 130 N·m. Remove the studs "C" used for assembly.

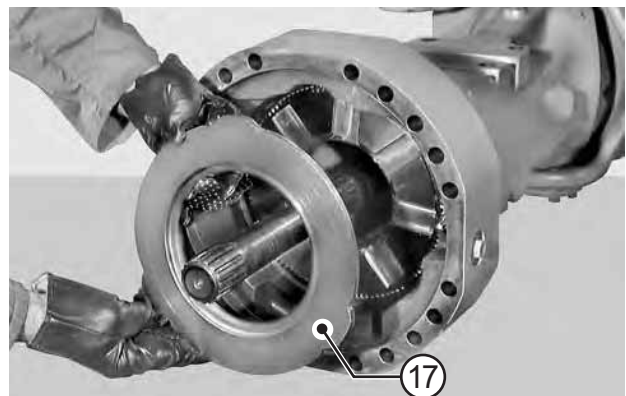

FIGURE 29: Install the thickest counter plate (17).

ASSEMBLY

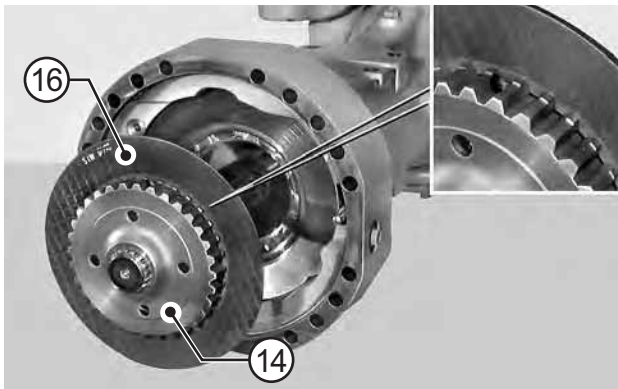

FIGURE 30: Lubricate the friction disc (16) with oil SAE 85W90; install friction disc and coupling (14).

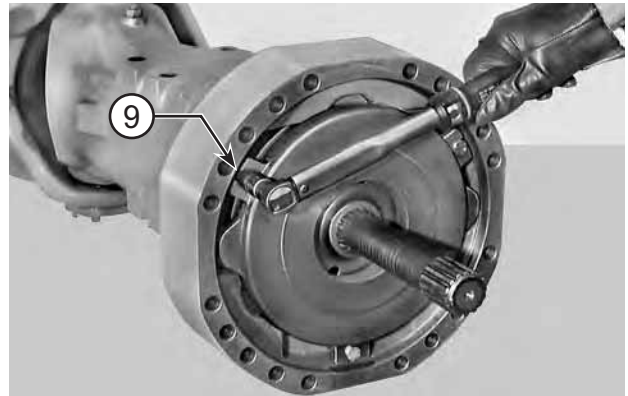

FIGURE 33: Tighten screws (9) sequentially and in several stages to a torque of 20 - 30 N·m.

⚠ CAUTION

Check coupling's direction of installation carefully.

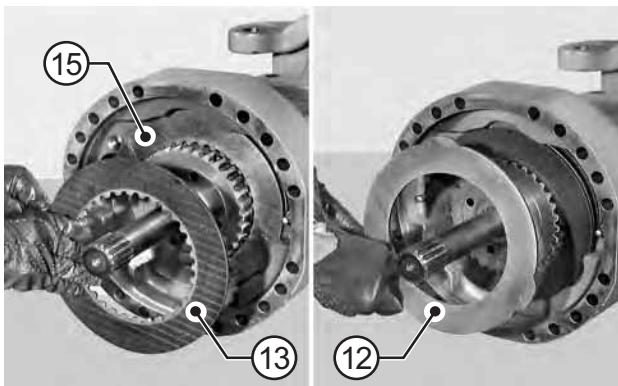

FIGURE 31: Install parts in the following sequence: intermediate disc (15), friction disc (13), and second intermediate disc (12).

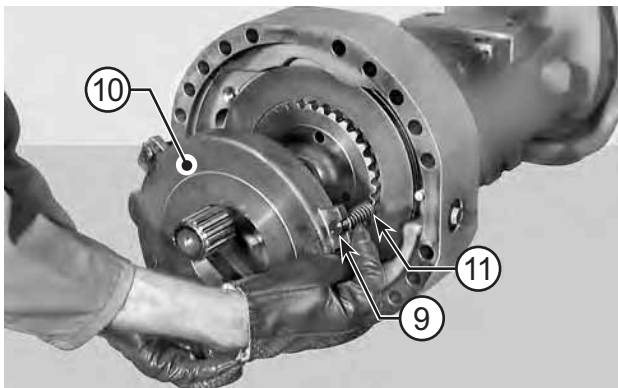

FIGURE 32: Install the thrust disc (10), springs (11), and screws (9).

⚠ CAUTION

Orient disc (10) to align on horizontal axis the negative brake release screws (36) recesses.

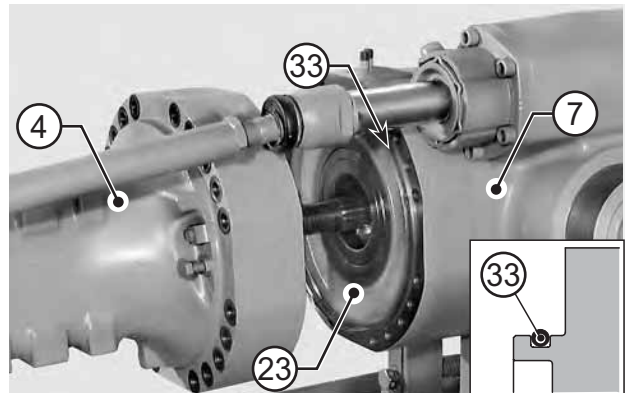

FIGURE 34: Fit a new o-ring (33) on the brake cylinder (23). Connect the complete arm (4) to a hoist and install it in the main body (7).

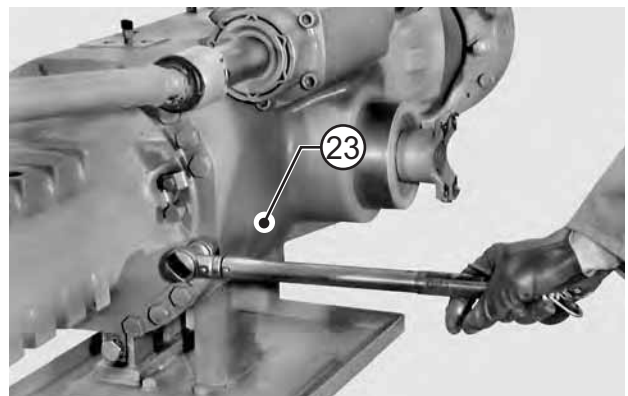

FIGURE 35: Fasten the arm to the brake cylinder (23) and attach the arm with screws and washers (6).

📌 NOTE:

Tighten screws to make the coupling faces just touch each other.

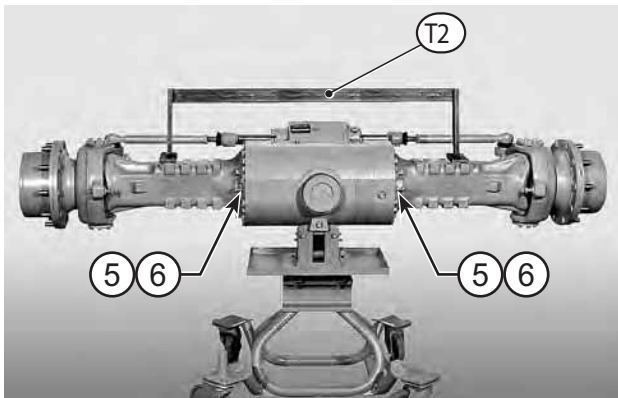

FIGURE 36: Using tool T2 (See drawing T2 p. 26) check that the arms are level, then finally lock them with screws (5) and washers (6) using the criss-cross method. Tightening torque: 283 - 312 N·m.



FIGURE 37: ADJUSTING BRAKES
When adjusting the brakes, connect a hydraulic pump to the access hole of the negative brake and introduce pressure at 20 - 25 bar to release the brake disc.

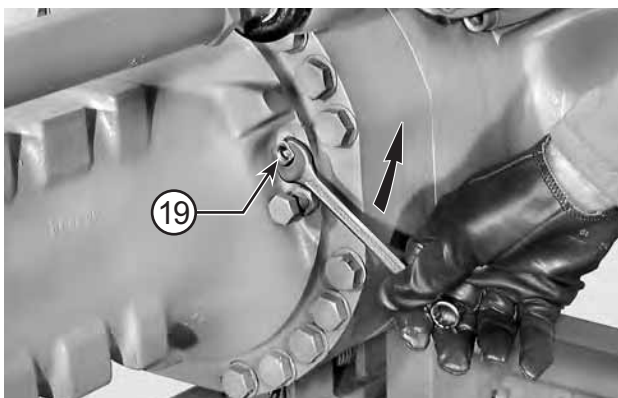

FIGURE 38: Rotate the pinion (19) counter-clockwise until it reaches the end of stroke and a slight torque is obtained.

NOTE:
All existing clearances between discs are eliminated as a result of this operation.

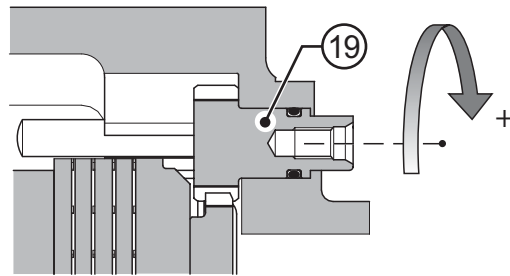

FIGURE 39: Rotate pinion (19) clockwise to obtain the accurate clearance.
Axles with two friction discs: 3 turns + 3 sides; clearance: 0.75 mm;
Axles with three friction discs: 5 turns; clearance: 1 mm.

NOTE:
Every turn of the pinion produces a clearance of 0.2 mm.

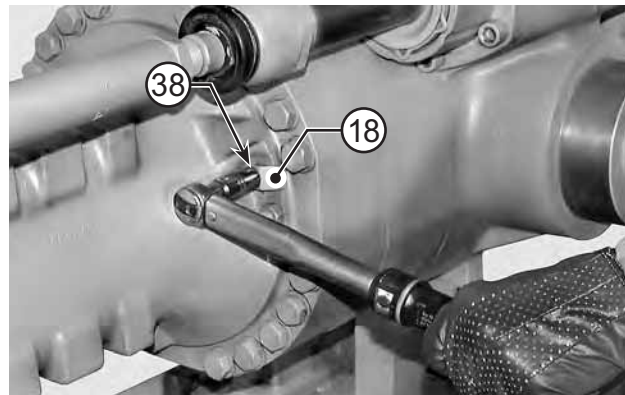

FIGURE 40: Release pressure, fit the catch (18) and lock with screw (38) coated with Loctite 242. Tighten screw to a torque of 20 - 30 N·m.

SPECIAL TOOLS

SPECIAL TOOLS

T1

P/N: 2362

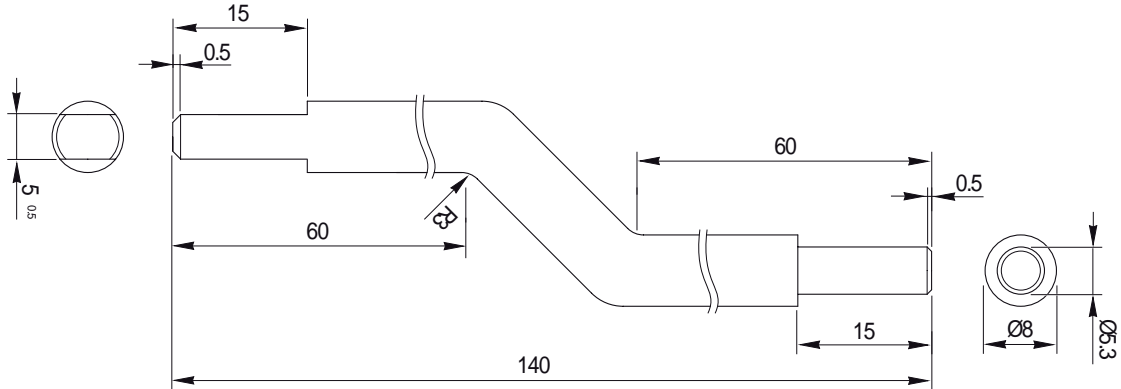

T2

P/N: 2363

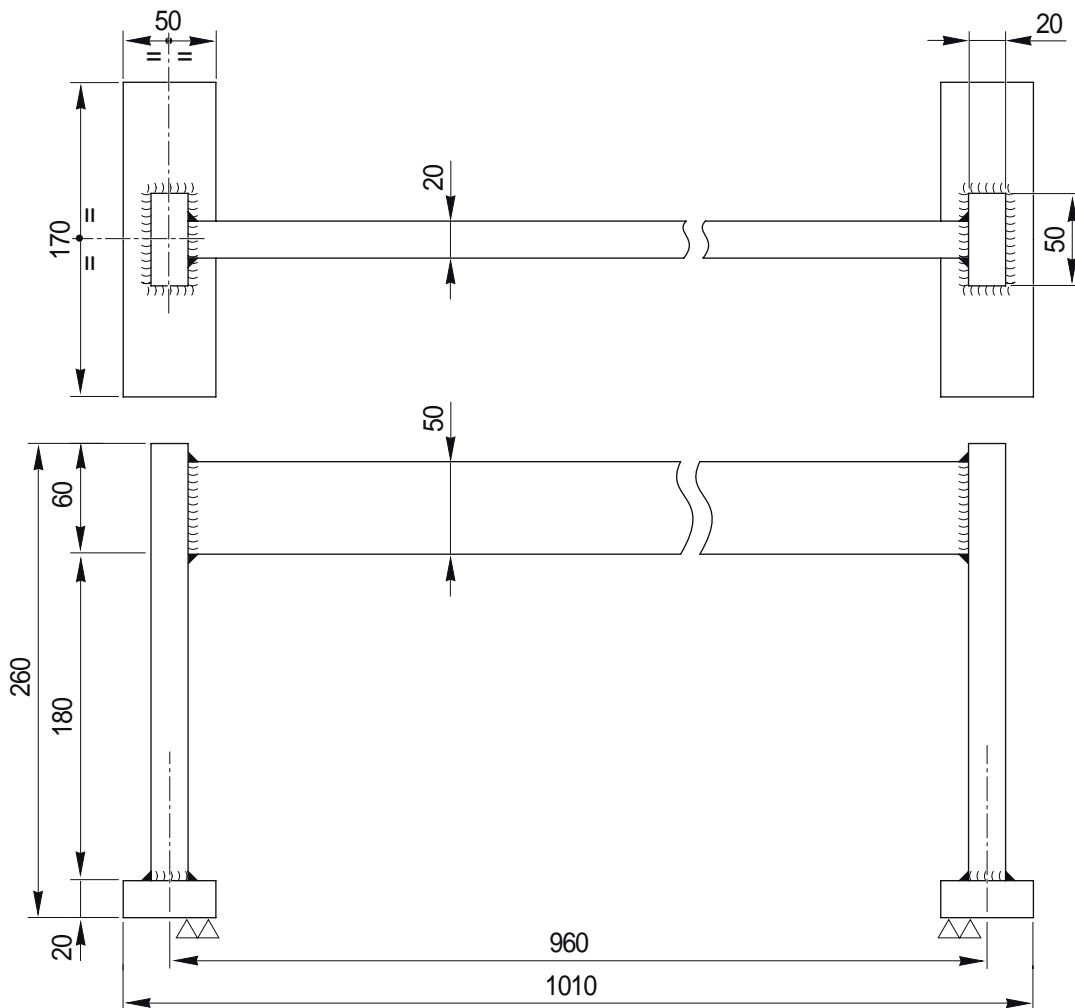

COMPLETE STEERING CASE

EXPLODED VIEW

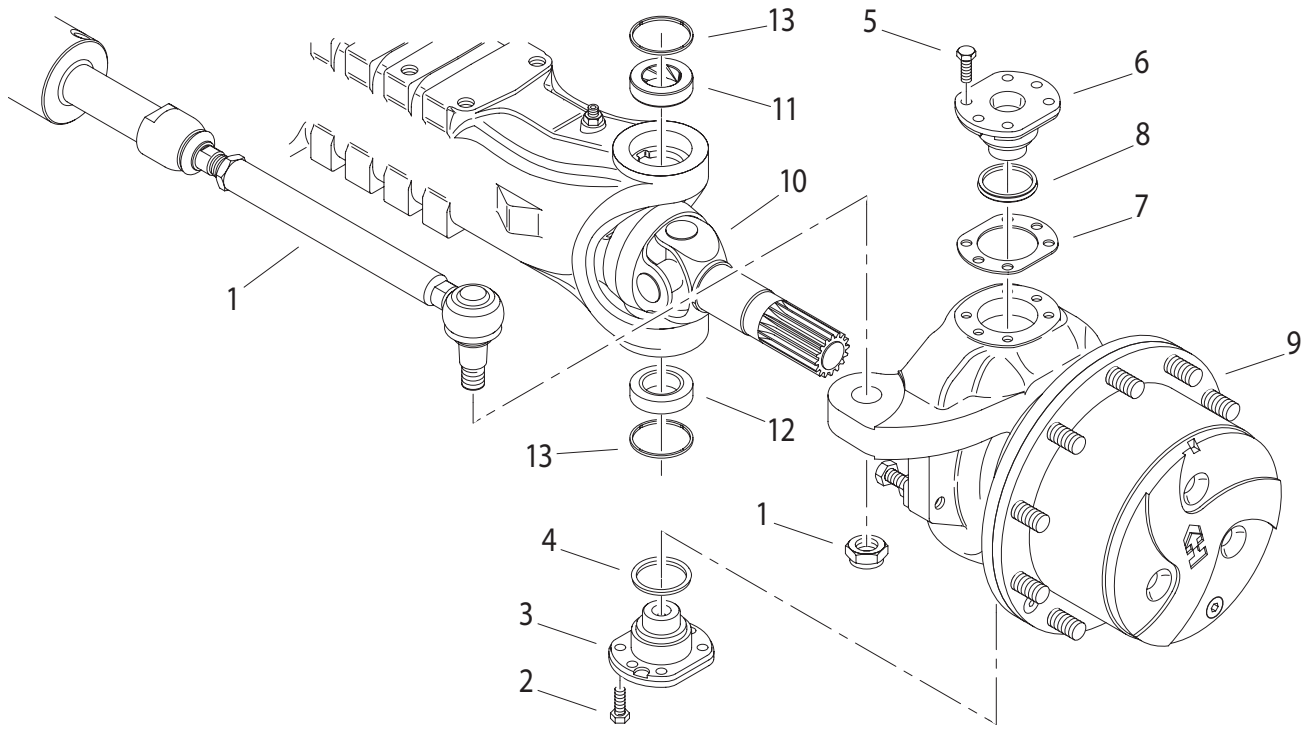

DISASSEMBLY

DISASSEMBLY

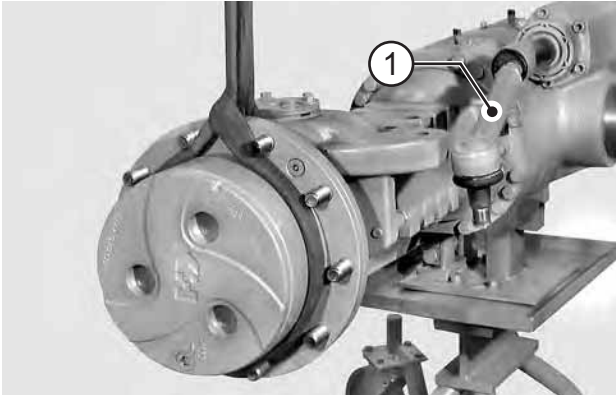

FIGURE 1: Disconnect the pivot of the steering bar (1) from the steering case. (See STEERING CYLINDER p. 61). Sling the whole unit (1) and connect it to a hoist; then lightly tighten the sling rope.

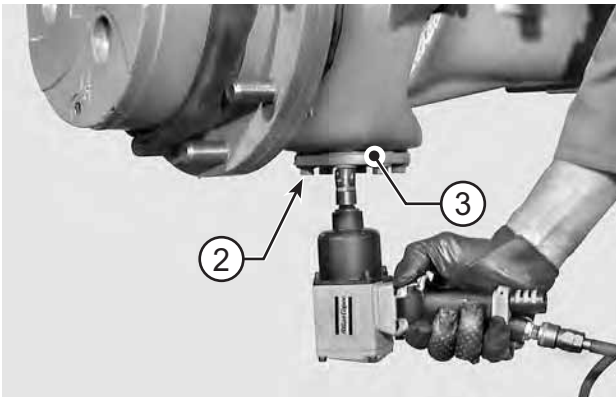

FIGURE 2: Loosen and remove the check screws (2) of the lower pivot pin (3).



FIGURE 3: Insert a screwdriver or lever alternately in the slots provided and pry out the lower pivot pin (3) along with the dust ring (4).

⚠ CAUTION

Replace the ring (4) at each disassembly.

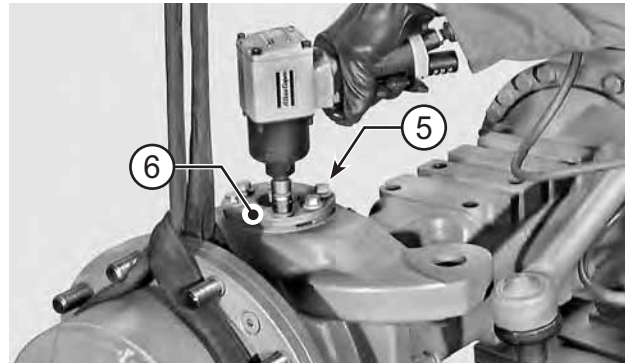

FIGURE 4: Loosen and remove the check screws (5) of the upper pivot pin (6).

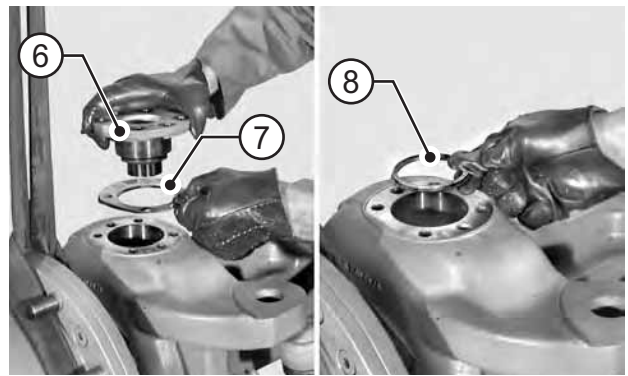

FIGURE 5: With the same method used for the lower pivot pin, remove the complete pivot pin (6), shims (7), and dust ring (8).

⚠ CAUTION

Replace ring (8) at each disassembly.



FIGURE 6: Remove the complete steering case (9) by drawing it out from the twin joint (10).

⚠ CAUTION

For twin joint seal ring replacement, see PLANETARY REDUCTION GEAR p. 49.

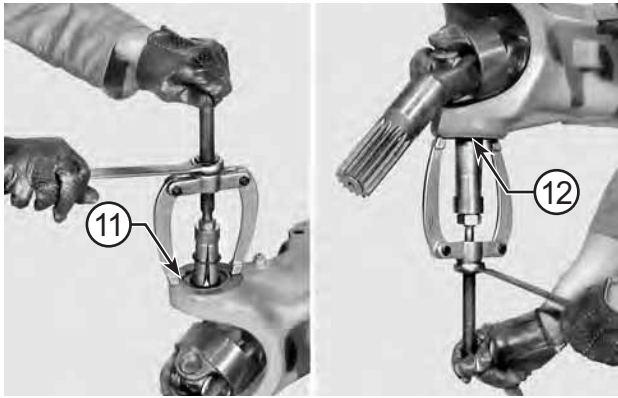

FIGURE 7: Using a puller for inner parts, remove the upper bushing (11) and lower ball bushing (12).

NOTE:

When bushings are pulled out, spacers (13) are removed as well.

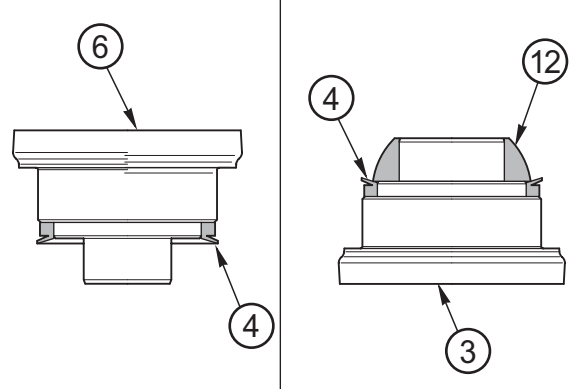

FIGURE 10:

- 6 - upper pivot pin
- 4 - dust ring
- 3 - lower pivot pin
- 12 - lower ball bushing



FIGURE 8: Remove the dust ring from the lower pivot pin (4).

NOTE:

Write down direction of installation.

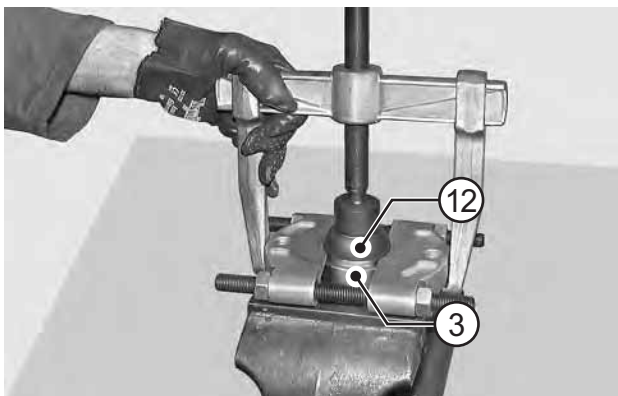

FIGURE 9: Only if round cap needs replacing, remove round cap (12) from lower pivot pin (3).

ASSEMBLY

ASSEMBLY

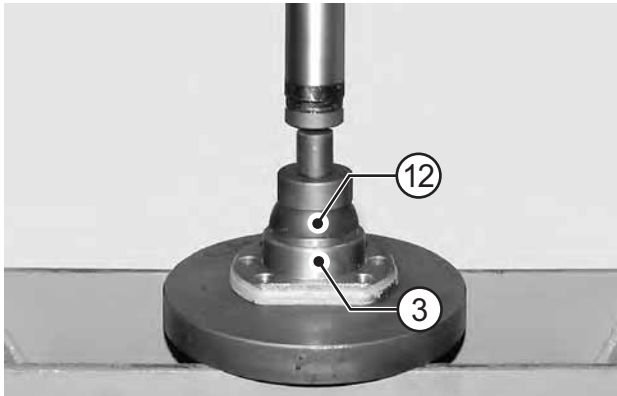

FIGURE 11: Only if lower pivot pin has been disassembled, position the lower pivot pin (3) under a press and fit the round cap (12).

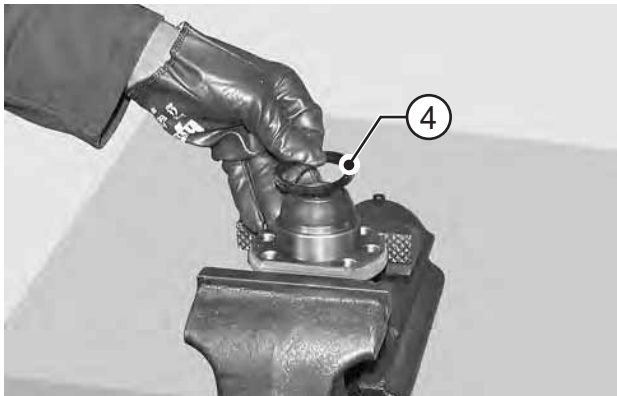

FIGURE 12: Fit the dust ring (4) onto the lower pivot pin.

NOTE:

Check orientation carefully.

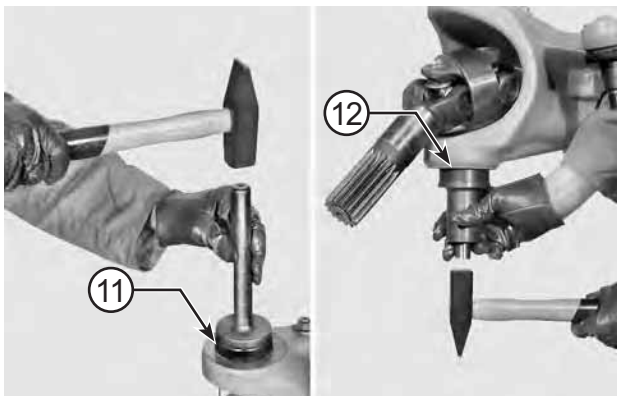

FIGURE 13: Lubricate the upper bushing (11) and round lower bushing (12). Fit them in the fulcrum holes provided on the arm, using a suitable tool.

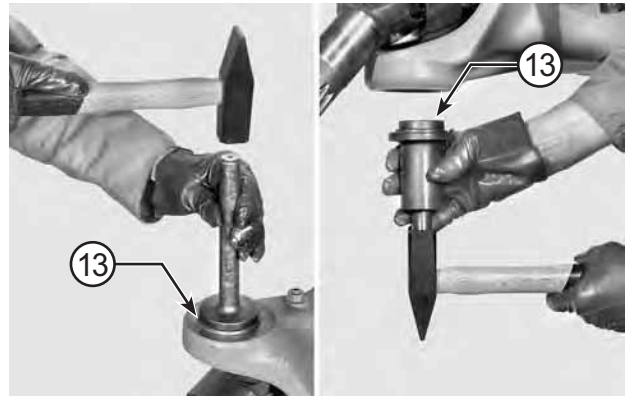

FIGURE 14: Install spacers (13) using the same tools.

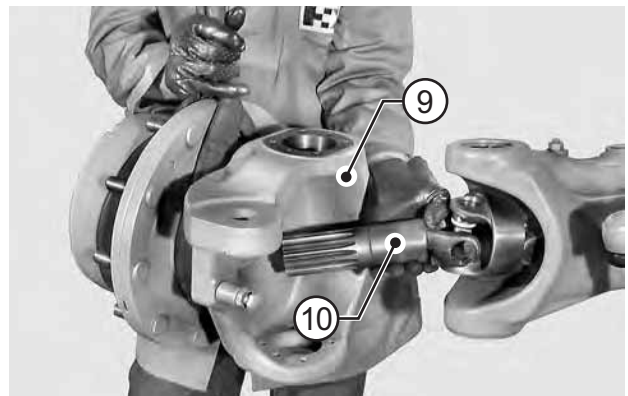

FIGURE 15: Lubricate the end part of twin u-joint (10) and mount steering case (9).

CAUTION

Pay special attention not to damage the seal ring of the twin joint.

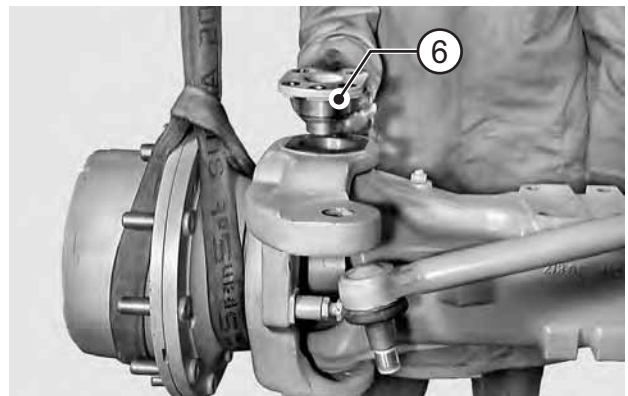

FIGURE 16: Make sure that the holes for the upper and lower fulcrum pins are perfectly coaxial, then fit the upper pivot pin (6).

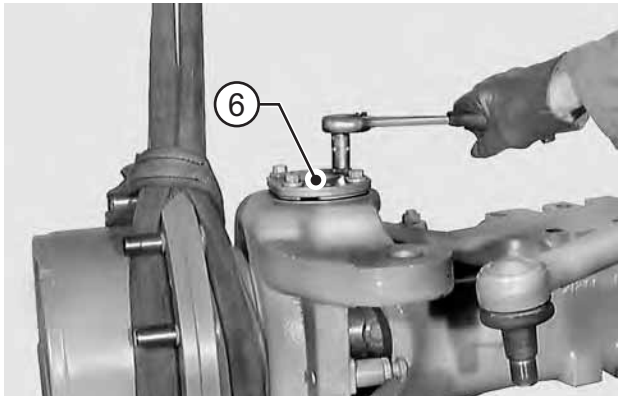

FIGURE 17: Temporarily lock the upper pivot pin (6) with four screws (5), but without shims.

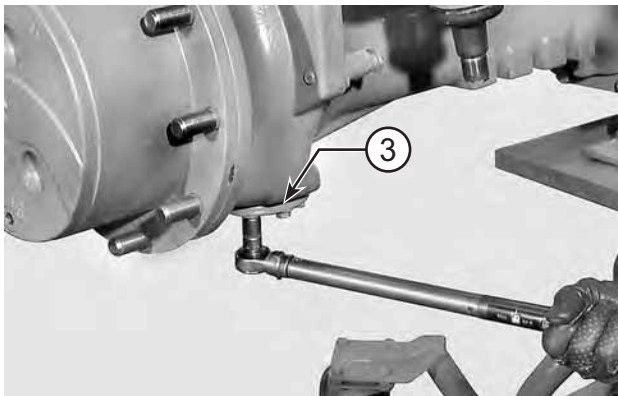

FIGURE 18: Fill the seat of the lower pivot pin with NLGI 3 EP grease and insert the complete pin (3). Apply a coat of Loctite 242 to the screws (2) and tighten until the pin is secured (3). Loosen upper pivot pin screws by about 4 mm and lock lower screws to a torque of 130 - 142 N·m using the criss-cross method.

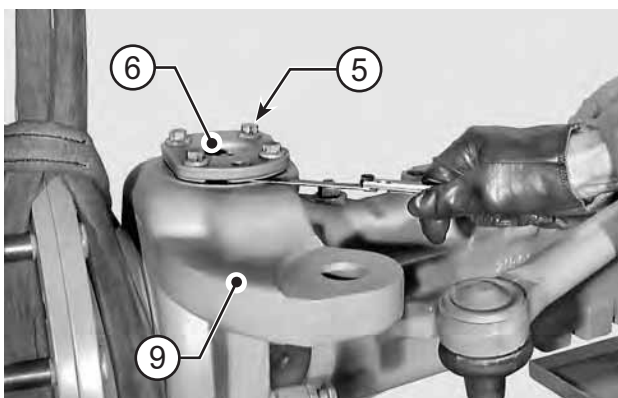

FIGURE 19: Tighten screws (5) of upper pivot pin (6) with the criss-cross method until a slight increase in the torque of the steering case (9) occurs. Using a feeler gauge, check clearance between upper pivot flange (6) and steering case; check several points.



FIGURE 20: Calculate the average of measurements taken and subtract 0 - 0.1 mm from the resulting measurement until you have rounded off to the lower decimal figure. Make up the pack of shims choosing among available shims.

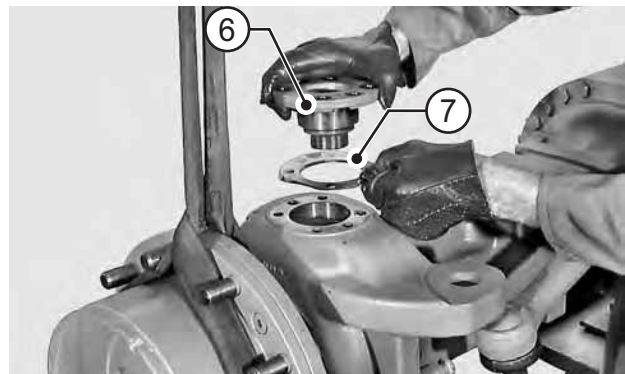

FIGURE 21: Remove upper pivot pin (6) and install the dust ring (8). Fill the seat of the upper pivot pin with NLGI 3 EP grease. Position the pack of shims (7) previously calculated and reinstall the upper pivot pin (6) with screws (5) coated with Loctite 242 to a torque of 130 - 142 N·m using the criss-cross method.

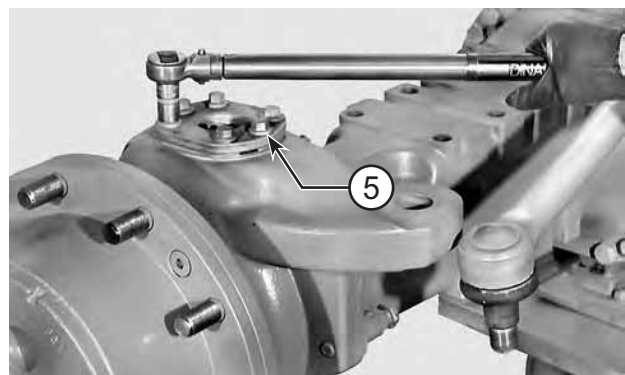

FIGURE 22: Check that the steering case is not jammed and has no vertical clearance; if necessary, recalculate shims as described earlier.

NOTE:

Thoroughly lubricate the two pivot pins with NLGI 3 EP grease.

SERVICE BRAKE AND NEGATIVE PARKING BRAKE

EXPLODED VIEW

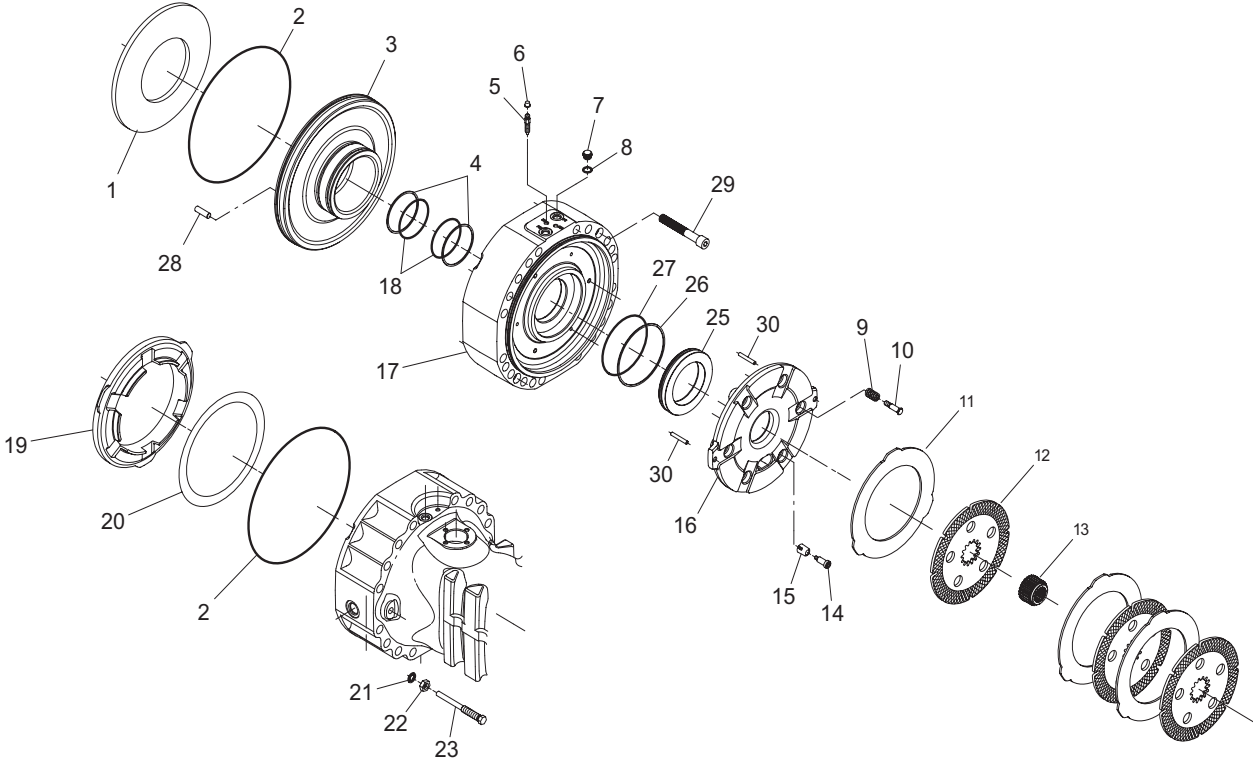

RELEASE

RELEASE

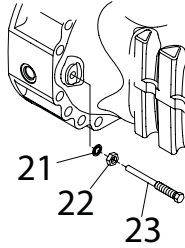

FIGURE 1: Loosen nuts (22) of screws (23) provided for the mechanical and manual release of the braking units, then move the nuts backwards by approximately 8 mm.

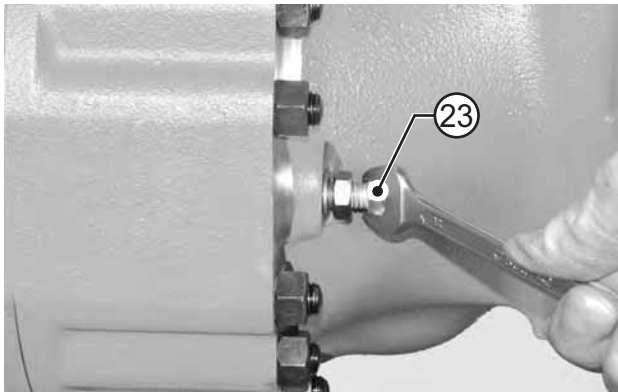

FIGURE 2: Tighten screws (23) to fasten them onto the pressure plate (16).

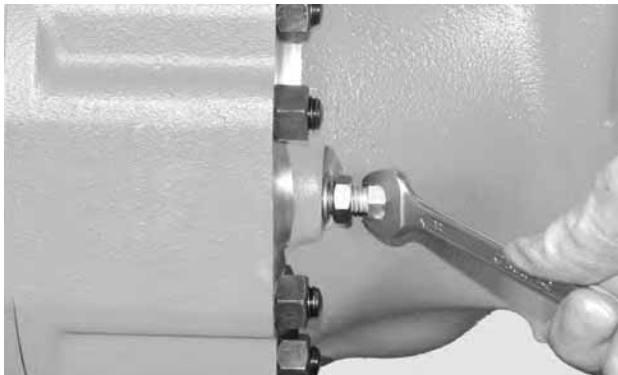

FIGURE 3: Using a wrench, tighten the screws (23) in an alternate sequence by 1/4 turn at a time so as to compress the Belleville washers (1) and disengage the braking disks.

⚠ CAUTION

Tighten maximum by one turn.

ADJUST

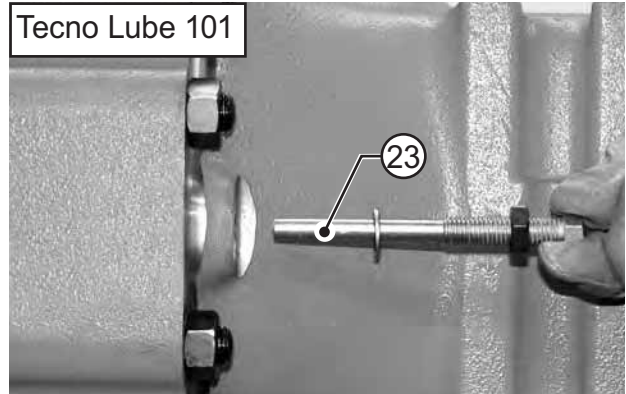

FIGURE 4: ADJUSTMENT AFTER MANUAL RELEASE
Remove screws complete with nuts and seals. Replace seals, apply silicone-based Tecno Lube /101 grease to the screws, and install all parts into the arm.

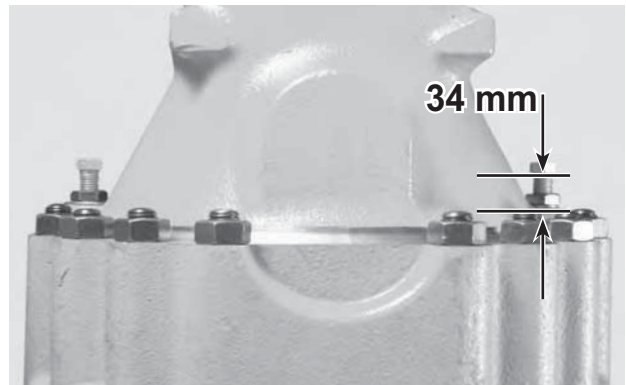

FIGURE 5: Adjust screws (23) to obtain a distance of 34 mm in relation to the arm.



FIGURE 6: Lock into position with nuts (22).

⚠ CAUTION

Hold screws (23) into position while locking the nuts (22); after locking, check the distance of screws (23) once more.

DISASSEMBLY

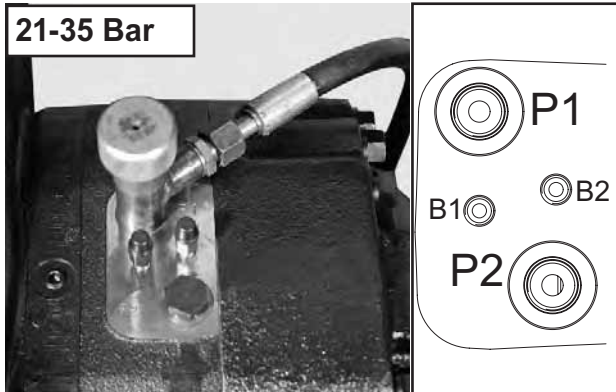

FIGURE 7: Connect an external pump to the union piece “P1” of the negative brake and introduce a pressure of 21 - 35 bar to eliminate the pressure of the Belleville washers (1).

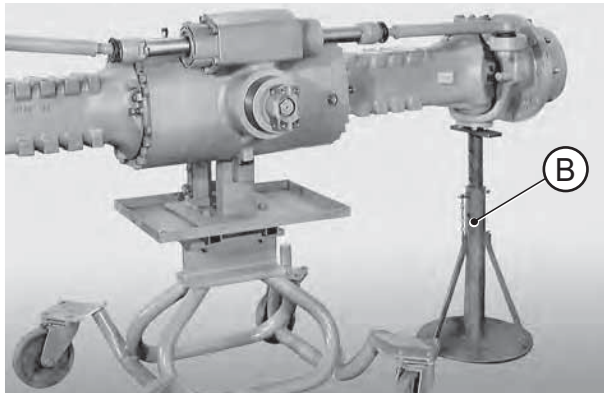

FIGURE 8: If axle is positioned on an overhaul bench, place a safety anti-tilting stand “B” under the arm that remains connected and block wheels, if any.

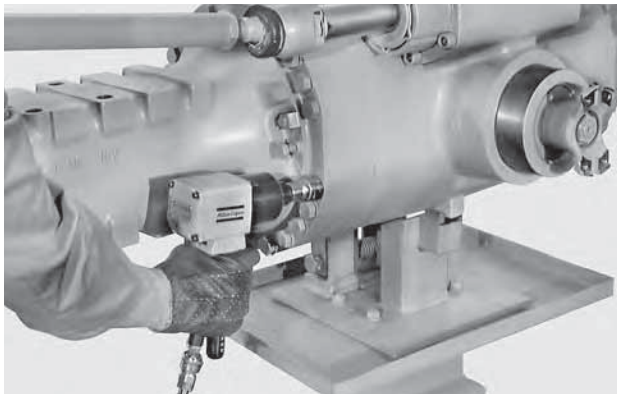

FIGURE 9: Sling the arm to be removed and connect it to a hoist. Remove the retainer screws and washers.

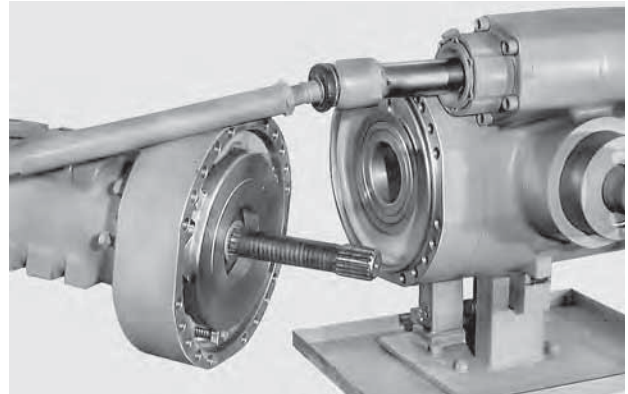

FIGURE 10: Remove arm together with brakes and axle shafts; lay down the arm vertically. Release pressure.



FIGURE 11: Remove braking discs (11)(12), noting down direction of assembly.

NOTE:

If disks are not being replaced, avoid changing their position.

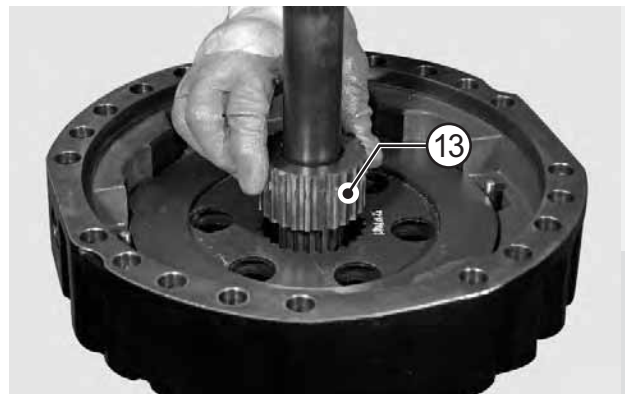

FIGURE 12: Remove the flange (13) complete with the discs, noting the direction of assembly.

DISASSEMBLY

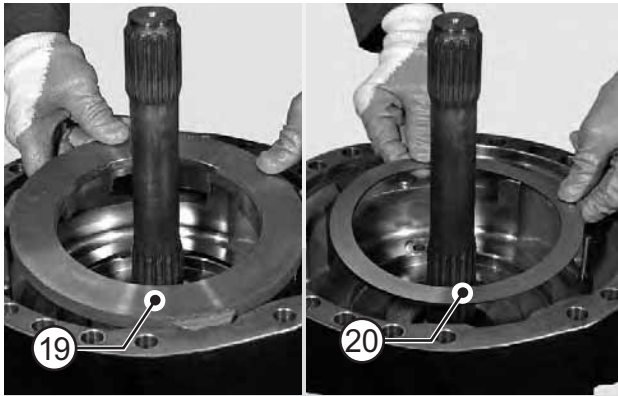

FIGURE 13: Remove spacer-braking discs (19) and shims (20) noting direction of assembly.

NOTE:

Build a stack of washers and check the measure.

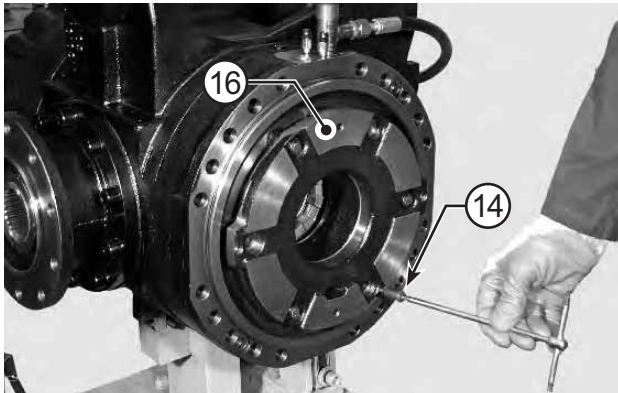

FIGURE 14: Remove the adjusting screws (14) from the counterwasher (16).



FIGURE 15: Remove the reversal springs (9) and screws (10).

NOTE:

If the springs (9) are weak or deformed they must be replaced.

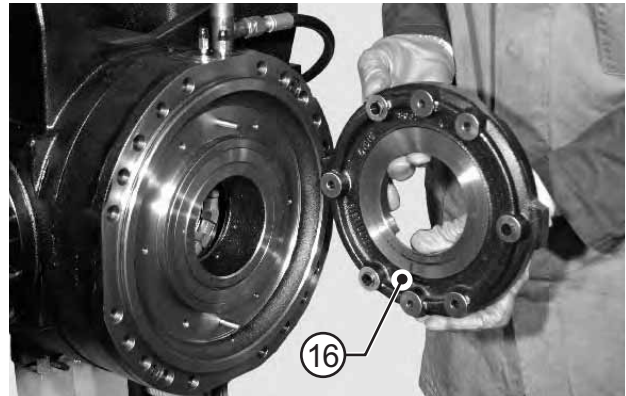

FIGURE 16: Write down the order of assembly and remove the counterwasher (16).

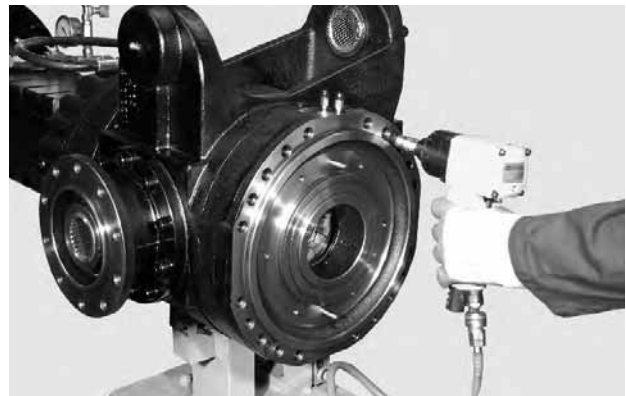

FIGURE 17: Loosen the screws (29) in an alternate manner and remove them.

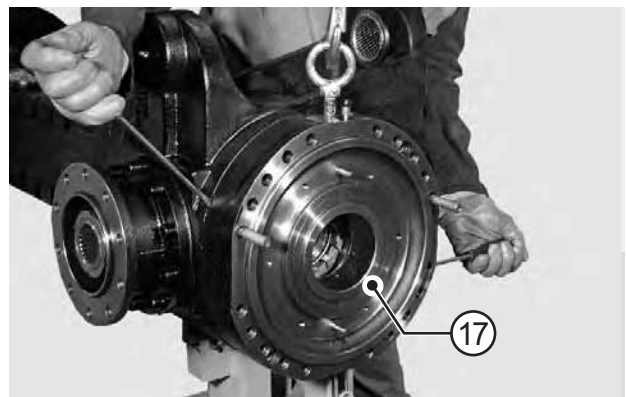

FIGURE 18: Remove the brake cylinder (17).

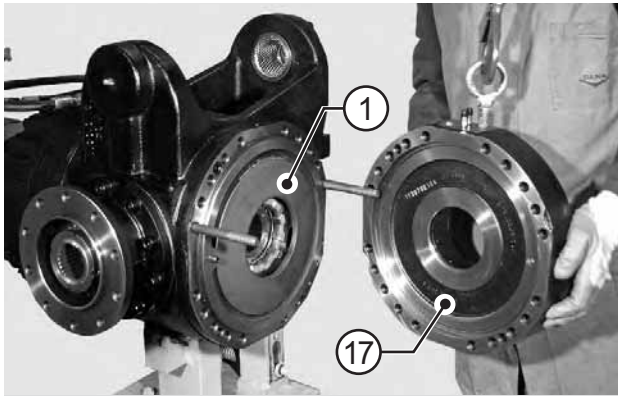

FIGURE 19: Move the cylinder (17) outwards while supporting the Belleville washers (1). Remove the Belleville washers (1) and write down the direction of assembly.

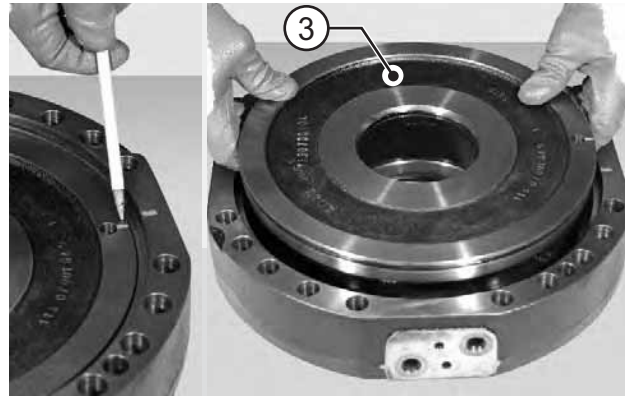

FIGURE 21: Slowly introduce low-pressure compressed air through the connection member for the negative brake (P1), in order to extract the piston (3).

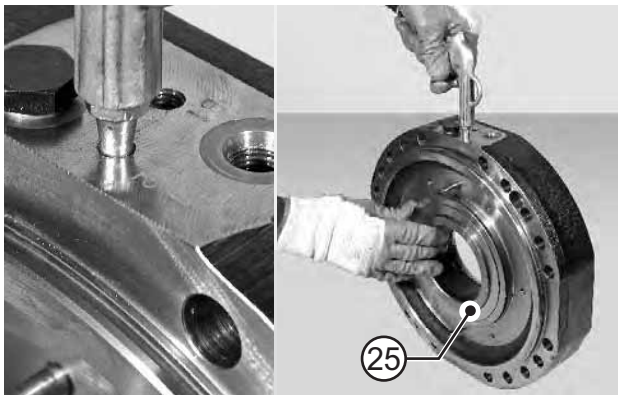

FIGURE 20: Slowly introduce low-pressure compressed air through the connection member for the service brake (P2), in order to extract the piston (25).

⚠ CAUTION

Hold the piston (3) back, as it may be suddenly ejected and damaged. Write down the order of assembly.

⚠ CAUTION

Hold the piston (25) back, as it may be suddenly ejected and damaged.

ASSEMBLY

ASSEMBLY

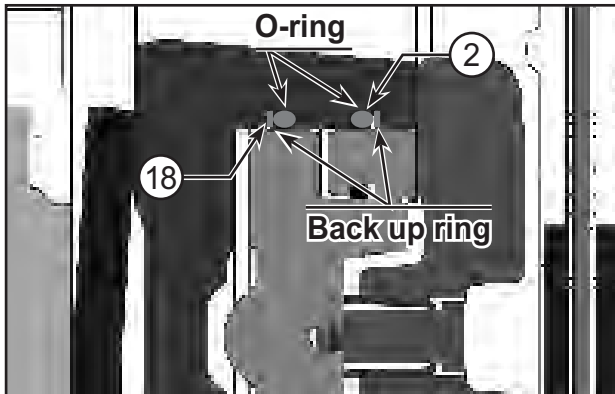

FIGURE 22: The o-rings always have to be assembled from the pressure facing side.



FIGURE 23: Fit o-ring (2) and (4) and anti-extrusion ring (18) onto the piston (3).

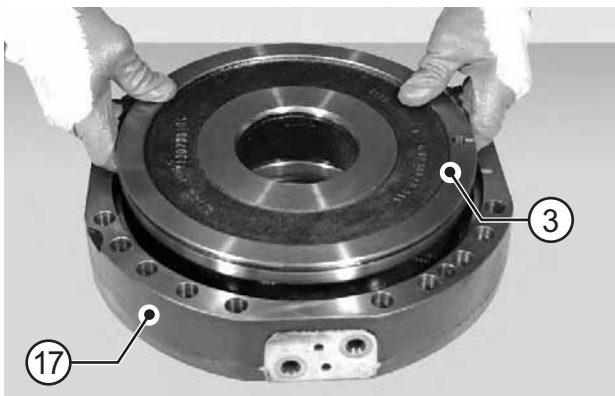

FIGURE 24: Check the position of the anti-extrusion (18) and o-rings (2) and (4). Lubricate the piston and the o-rings and install the unit (3) into the cylinder (17) .



FIGURE 25: Using a plastic hammer, install the piston (3) into the cylinder (17).

NOTE:

Lightly hammer all around the edge in an alternate sequence.

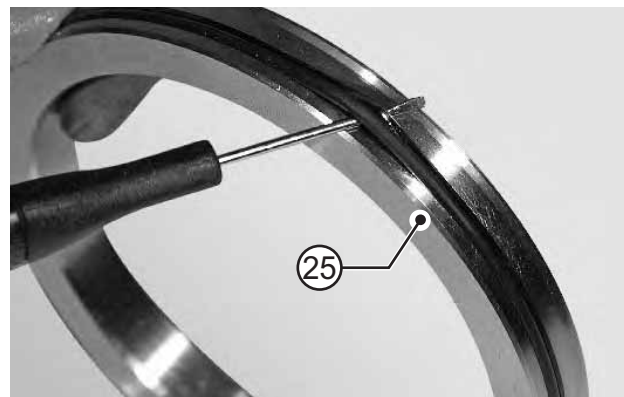

FIGURE 26: Fit o-ring (27) and anti-extrusion ring (26) onto the piston (25).



FIGURE 27: The o-rings always have to be assembled from the pressure facing side.

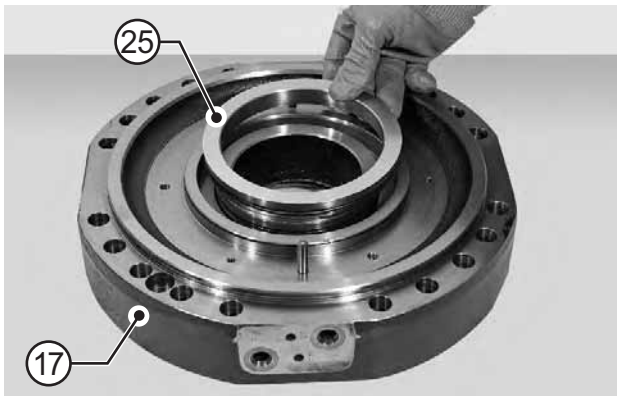

FIGURE 28: Lubricate the piston and the o-rings and install the unit (25) into the cylinder (17) .



FIGURE 29: Using a plastic hammer, install the piston (25) into the cylinder (17).

NOTE:

Lightly hammer all around the edge in an alternate sequence.

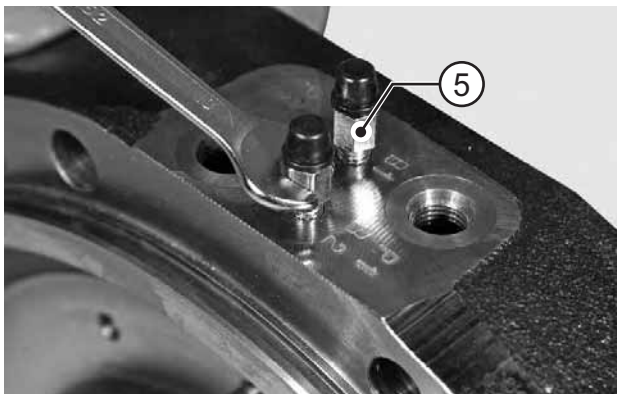

FIGURE 30: Assemble the breather (5).

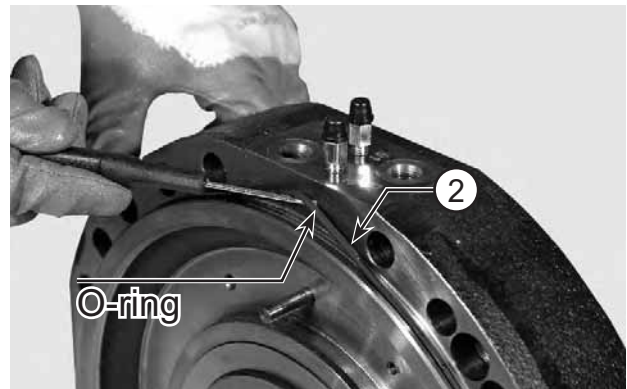

FIGURE 31: Check condition and position of the cylinder's o-ring (2).

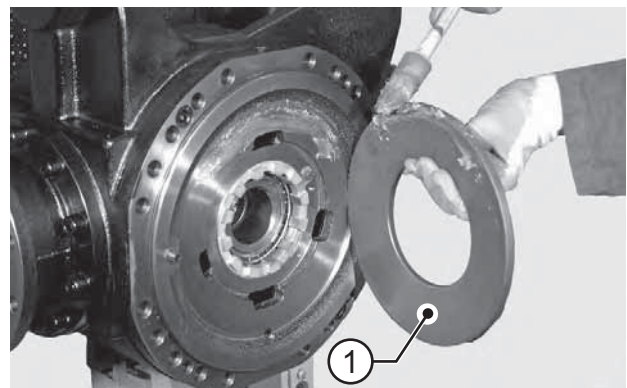

FIGURE 32: Position the Belleville washers (1) and engage the cylinder, spread grease over the contact surfaces to hold them in position while mounting on the central housing.

NOTE:

Check the sense of direction of Belleville washers (1) and relative centering.

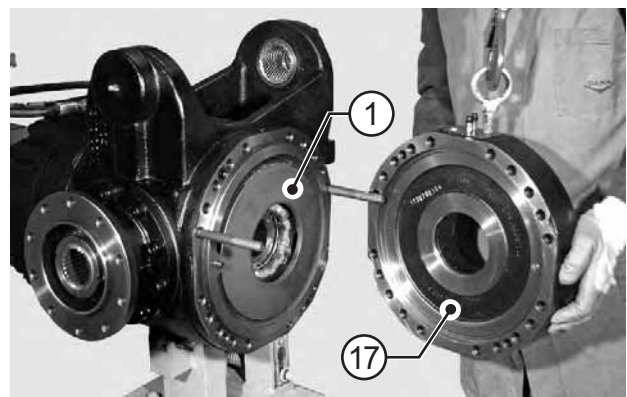

FIGURE 33: Install the cylinder (17).

NOTE:

Check the sense of direction of washers (1) and relative centering.

ASSEMBLY

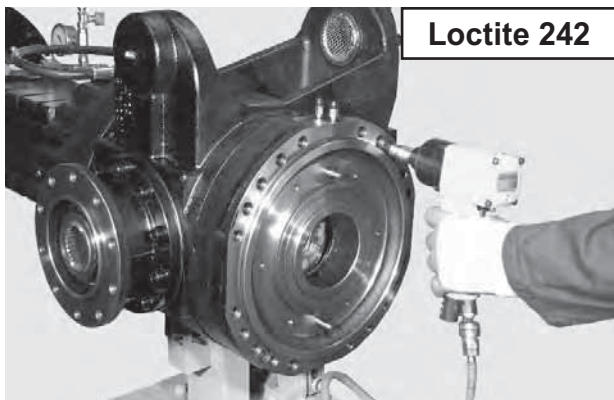

FIGURE 34: Insert the screws (29) and tighten them alternately. Lock the cylinder (17).

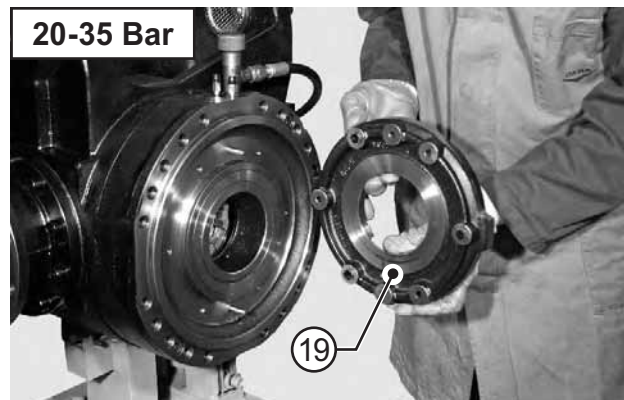

FIGURE 37: Insert the intermediate disc (19). Connect an external pump to the negative brake and introduce pressure to 20 - 35 bar.

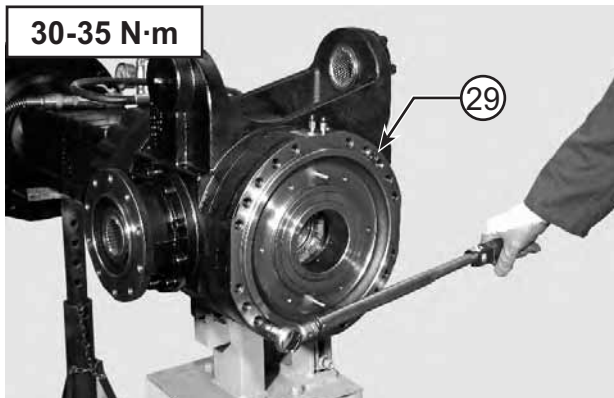

FIGURE 35: Tightening the screws (29) with a torque wrench set to 30 - 35 N·m.

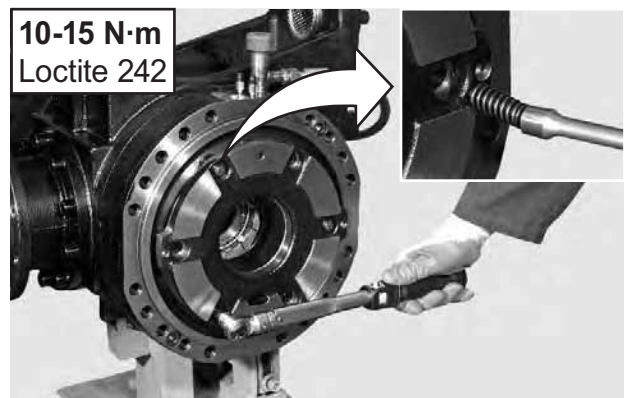

FIGURE 38: Install the reversal springs (9) and screws (10) on the intermediate disk (16). Apply LOCTITE 242 to the thread of the screw. Tighten to a torque wrench setting of 10 - 15 N·m

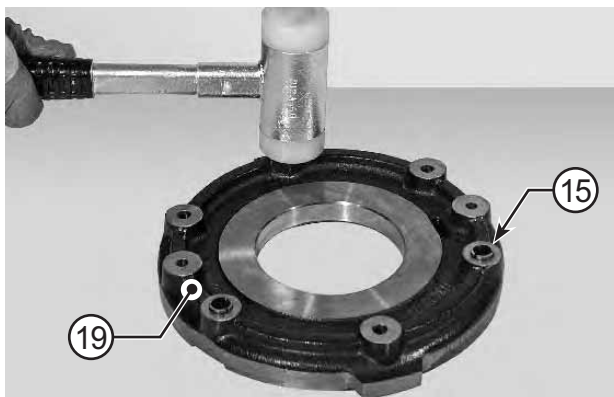

FIGURE 36: Insert the stroke automatic regulation springs (15); place them in line with the intermediate disc (19).

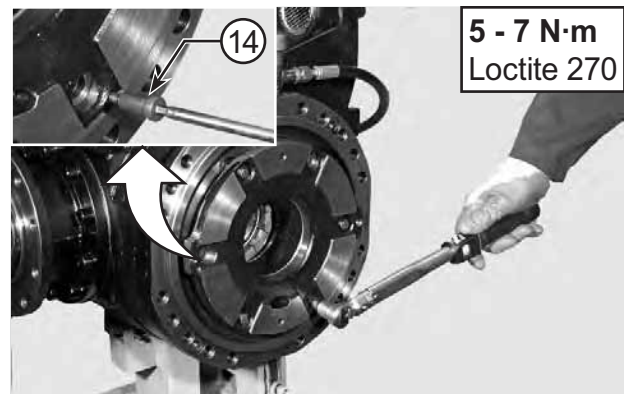

FIGURE 39: Install the adjusting screws (14). Apply Loctite 270 to the thread and torque to 5 - 7 N·m.



FIGURE 40: Take the measurement from the surface of the intermediate disk to the cover sealing surface with 20 - 35 bar of pressure introduced.
EXAMPLE: 30,6 mm

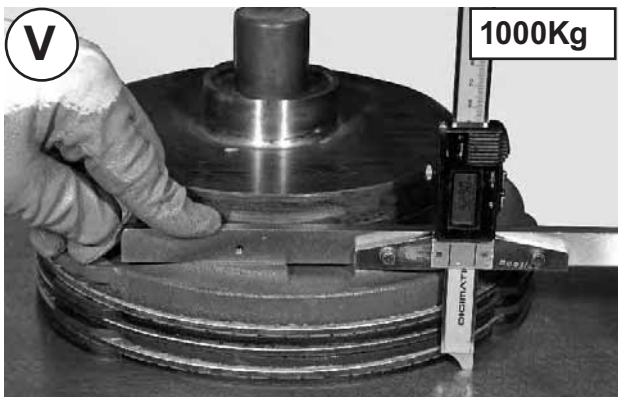

FIGURE 41: Put the brake disc pack including the shim under a press. Load with 1000 kg and take the measure "V".
EXAMPLE: V = 52,9 mm

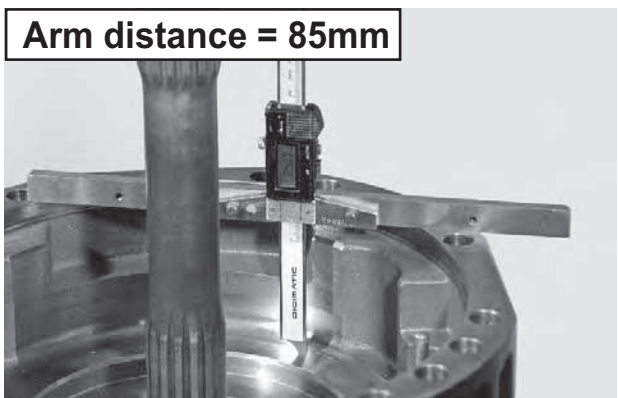
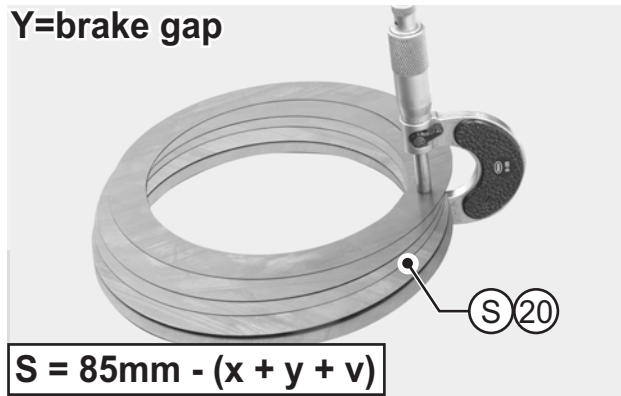

FIGURE 42: Arm distance = 85 mm

Y=brake gap



$$S = 85\text{mm} - (x + y + v)$$

FIGURE 43: $S = 85 \text{ mm} - (x + y + v)$ = Thickness of shims to insert under the shim washer.
EXAMPLE: $85 \text{ mm} - (30,6 + 52,9 + 1) = S = 0,5 \text{ mm}$

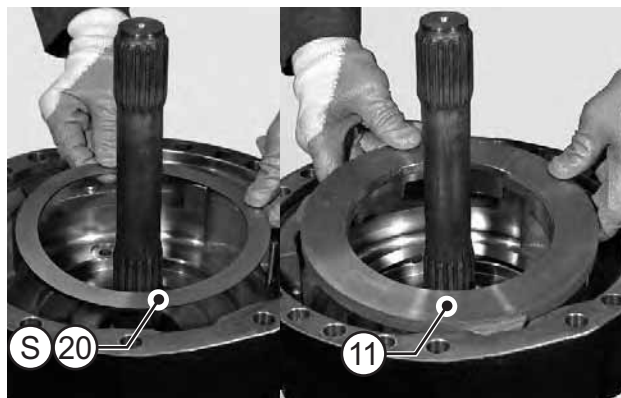

FIGURE 44: Insert under the shim washer a thickness of shims (20).

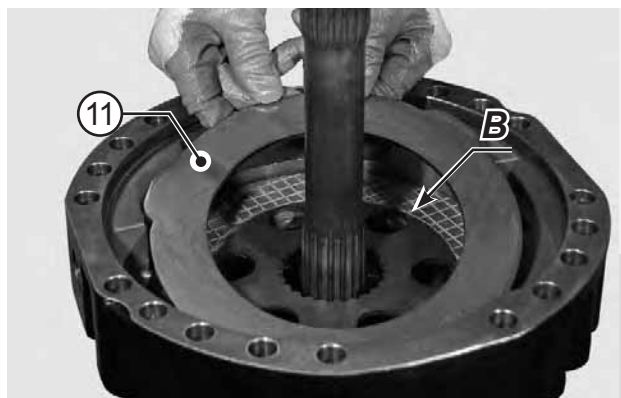

FIGURE 45: Slightly lubricate the braking disks (11) and (12) and fit them in the arm following the correct sequence. Orient so that the oil circulation holes and the marks "B" are perfectly lined up.

ASSEMBLY

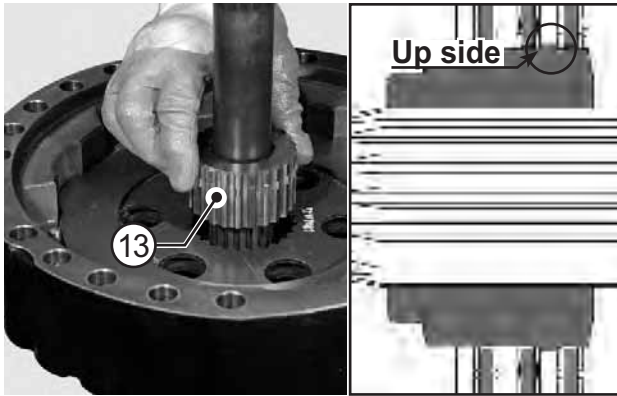

FIGURE 46: Install the flange (13) on the arm.

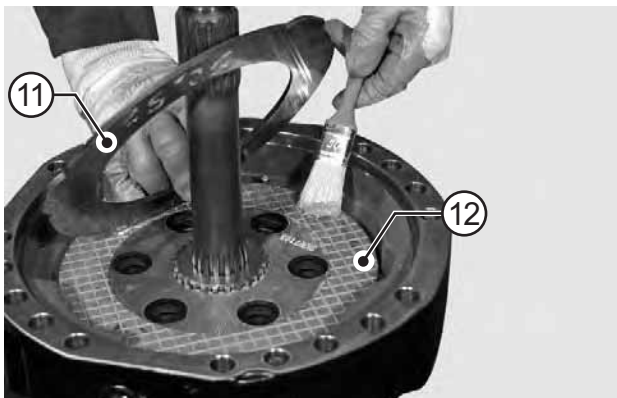

FIGURE 47: Insert the brake discs (11) and (12) in the right sequence.

NOTE:

The last brake disc to be inserted must be steel material.

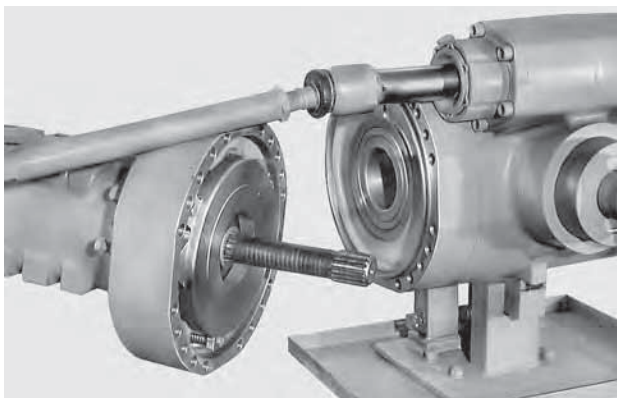

FIGURE 48: Check condition and position of the arm's o-ring. Install the complete arm.

NOTE:

To assist axle shaft centering, slightly move the wheel hub.

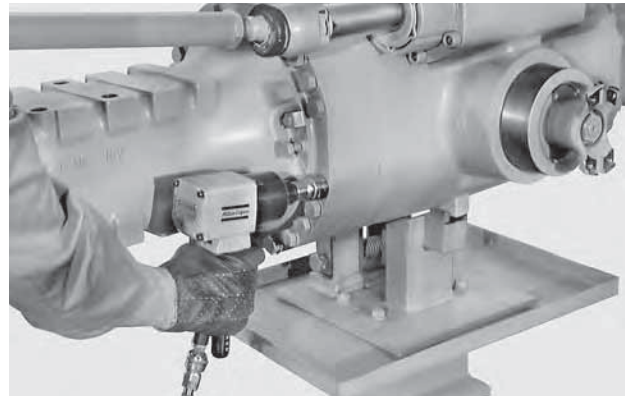

FIGURE 49: Temporarily lock the arm with nuts previously coated with Loctite 242; tighten lightly to make the unit touch the main body.

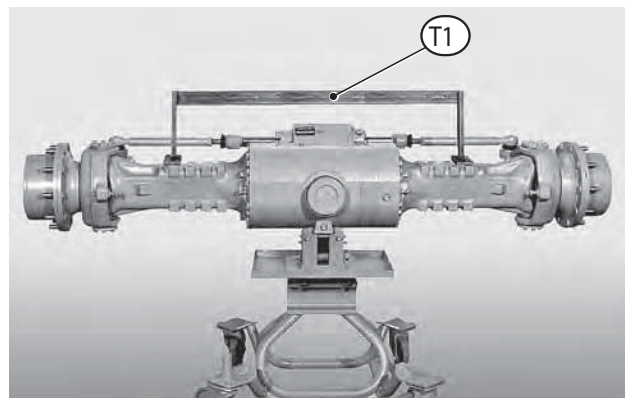

FIGURE 50: Check that the arms are level, using tool T1 (See drawing T1 p. 43); then lock the arms into their final position, using screws adequately coated with Loctite 242.

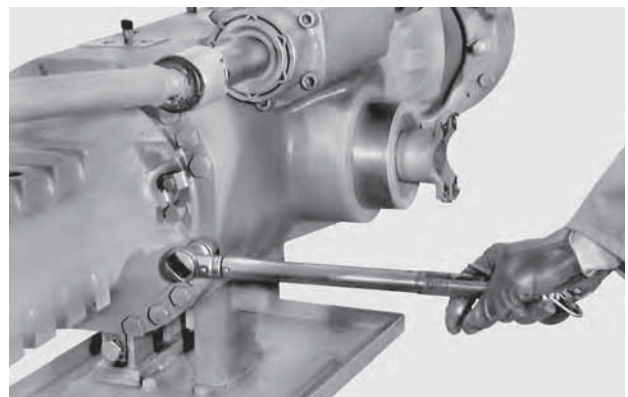
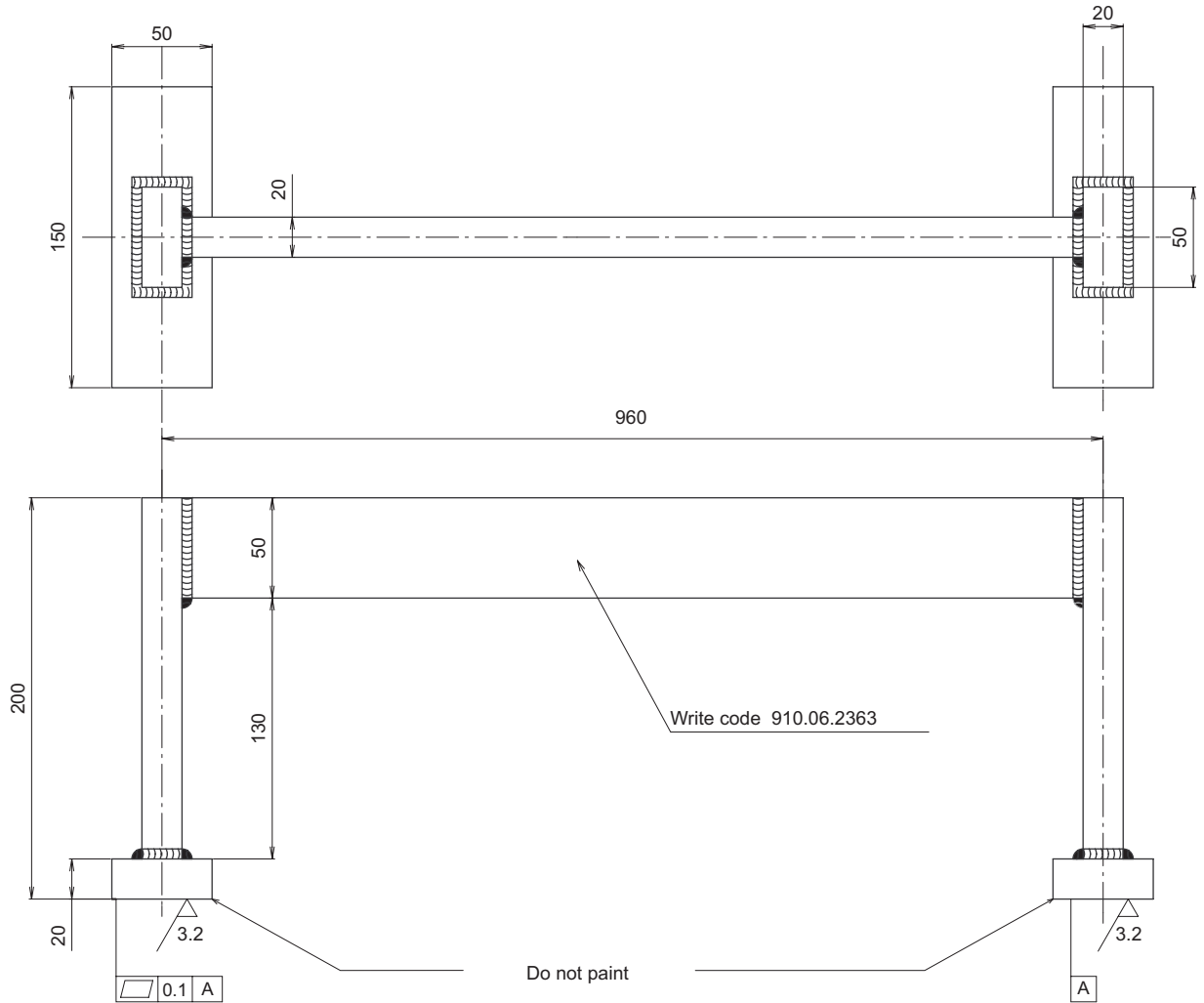

FIGURE 51: Secure in position with the screws and washers, by tightening to a torque of 298 N·m.

SPECIAL TOOLS

T1

P/N: 910.06.2363



DOUBLE U-JOINT

EXPLODED VIEW

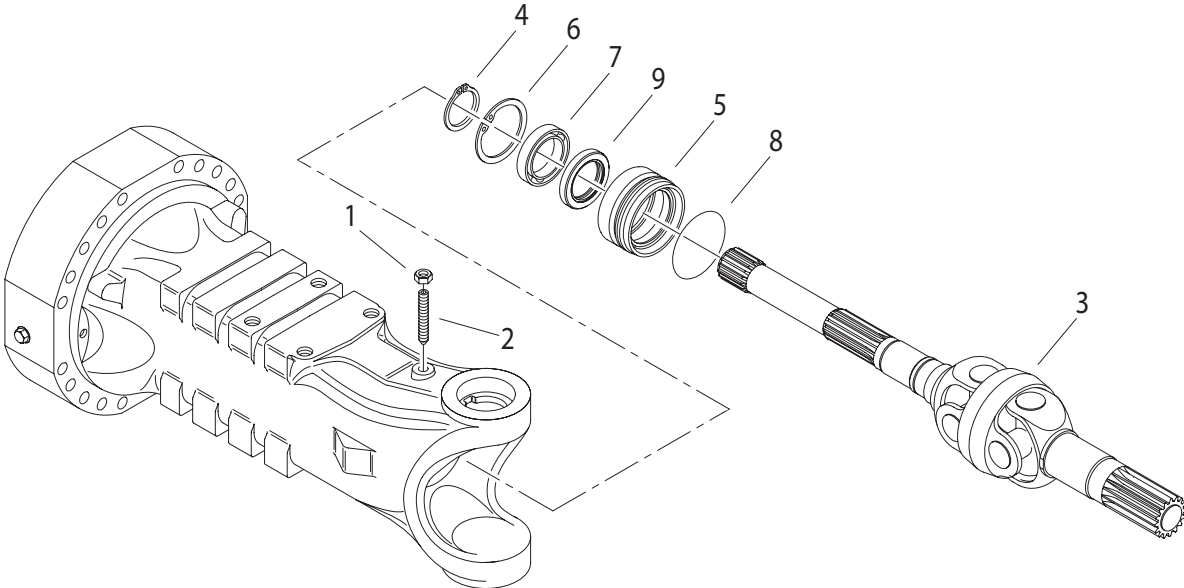

DISASSEMBLY

DISASSEMBLY

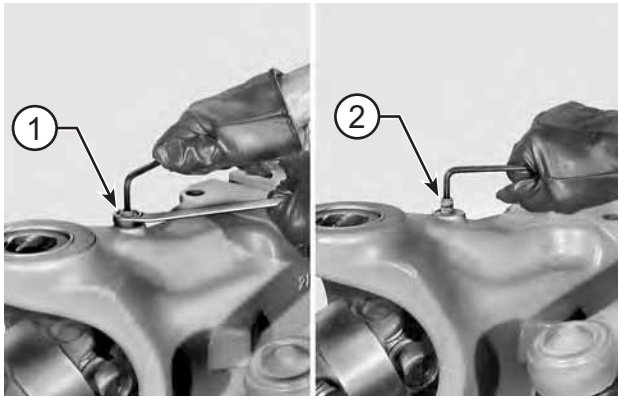

FIGURE 1: Loosen and remove the check nut (1) of the stud (2). Remove stud (2).



FIGURE 2: Extract the whole twin u-joint (3).

NOTE:

If necessary, use a plastic hammer or lever to ease extraction of the twin u-joint.

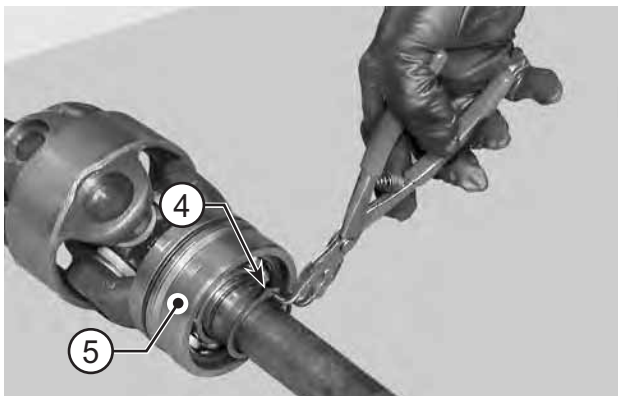

FIGURE 3: Remove the bushing (5) snap ring (4).

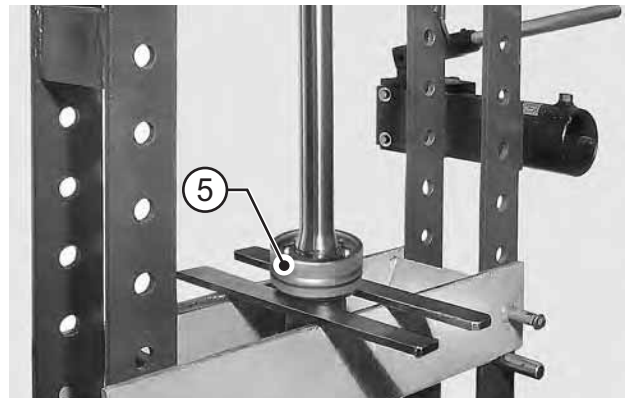

FIGURE 4: Place the u-joint under a press and remove the complete bushing (5).

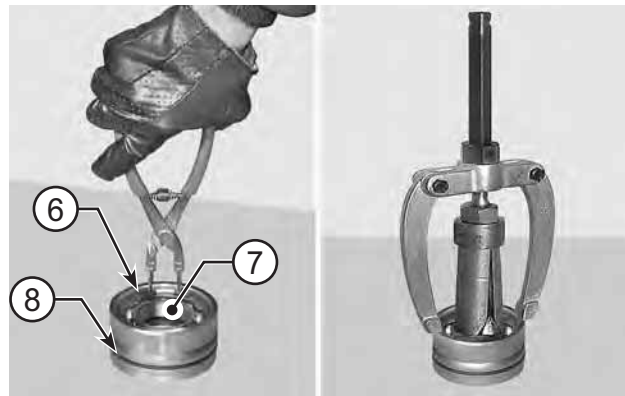

FIGURE 5: Remove the bearing (7) snap ring (6). Remove the o-ring (8) and, using a puller for inner parts, remove the bearing (7) and seal ring (9).

NOTE:

Write down direction of installation of seal ring.

ASSEMBLY

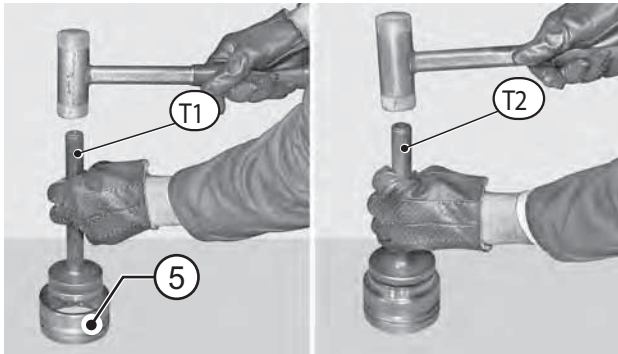

FIGURE 6: Using tools T1 (See drawing T1 p. 48) and T2 (See drawing T2 p. 48), introduce the seal ring (9) and bearing (7) into the bushing (5).

NOTE:

Check direction of installation of seal (9) carefully.

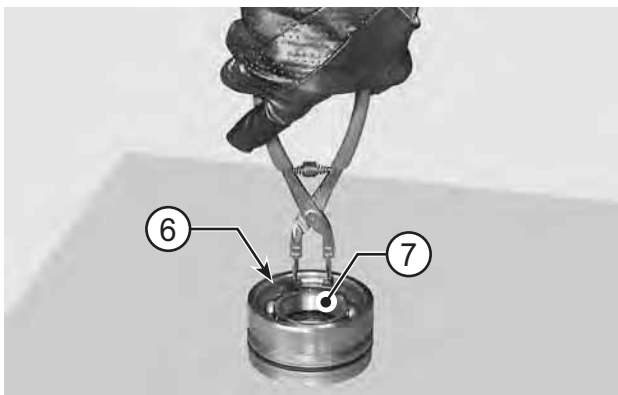

FIGURE 7: Install the bearing (7) snap ring (6).

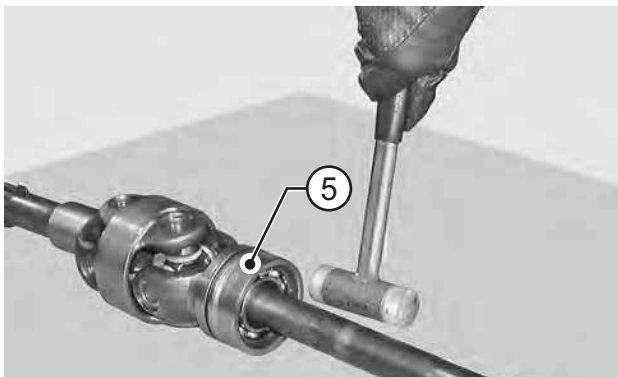

FIGURE 8: Install the complete bushing (5) onto the twin u-joint and set bushing into position with a plastic hammer.

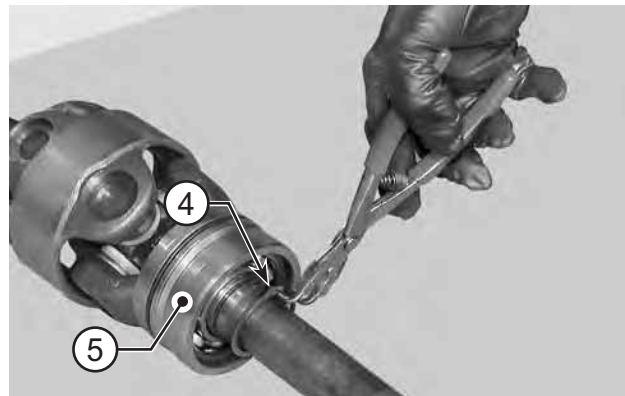

FIGURE 9: Install the bushing (5) snap ring (4) and position the o-ring (8) as well.

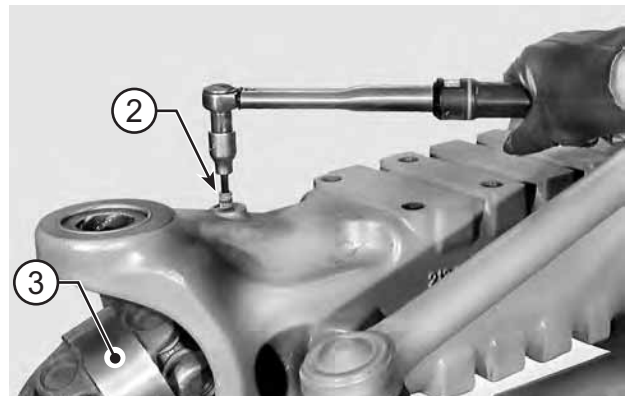

FIGURE 10: Introduce the twin u-joint (3) into the arm and lock into position with stud (2) coated with Loctite 242. Tighten stud to a maximum torque of 15 N·m.

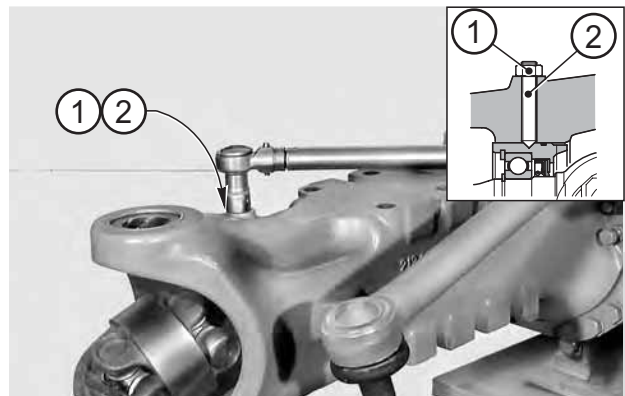

FIGURE 11: Apply Loctite 242 to the jutting portion of the stud (2) and tighten nut (1) to a torque of 60 - 70 N·m while holding stud (2) in position.

CAUTION

Tap around the whole rim.

SPECIAL TOOLS

SPECIAL TOOLS

T1

P/N: 3342

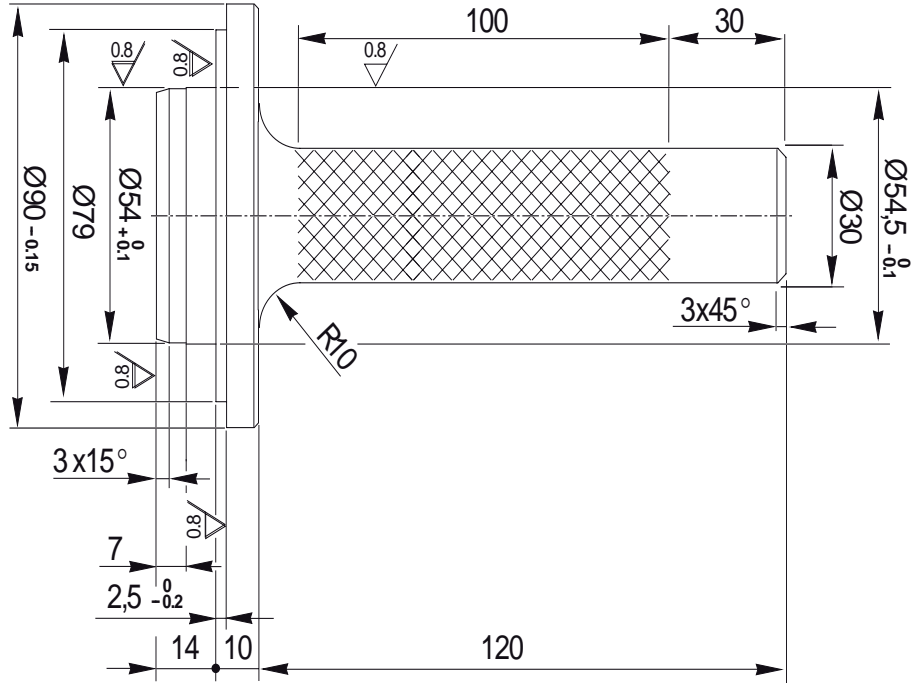

T2

P/N: 2301

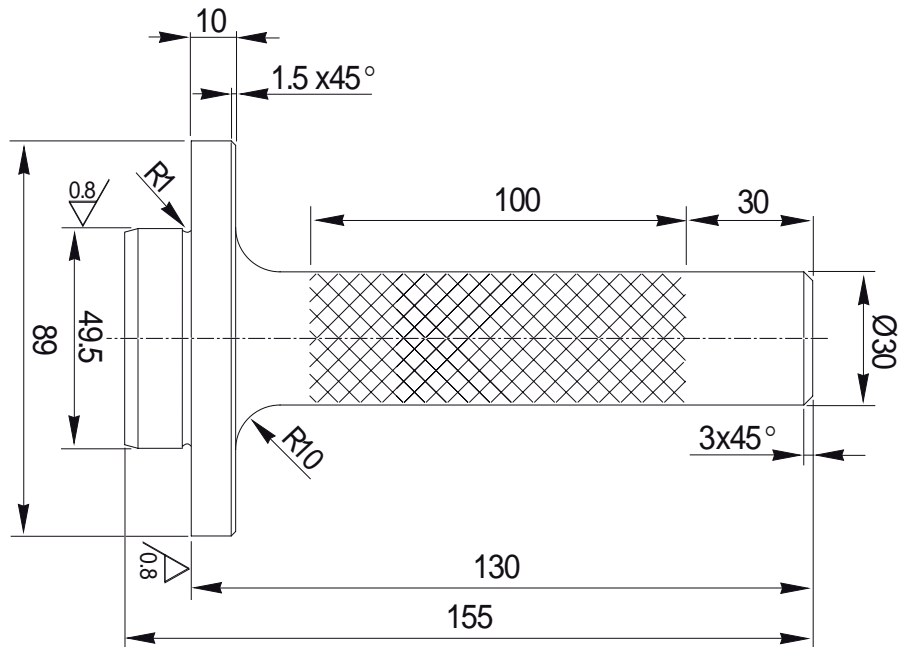

PLANETARY REDUCTION GEAR

EXPLODED VIEW

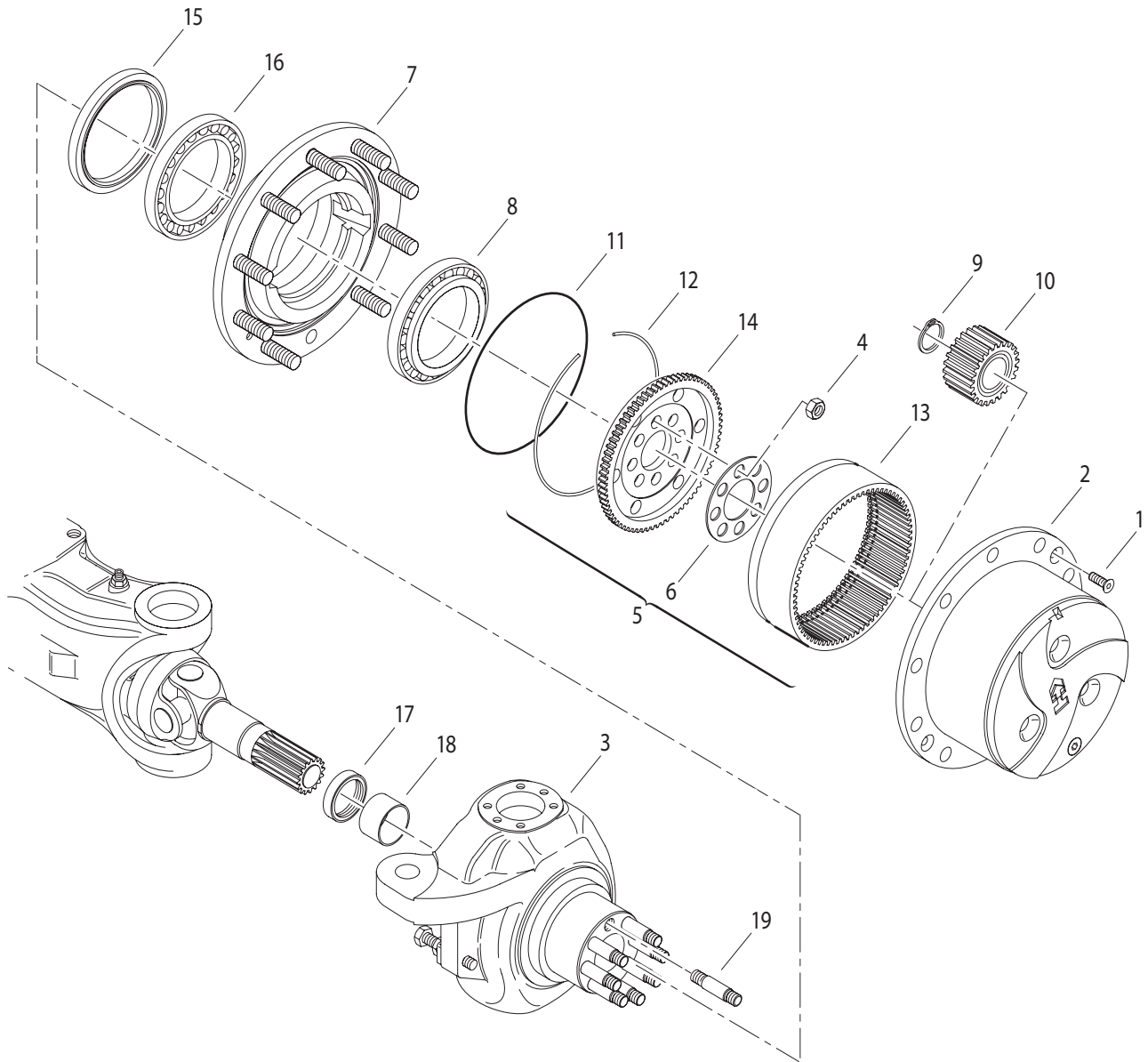

DISASSEMBLY

DISASSEMBLY

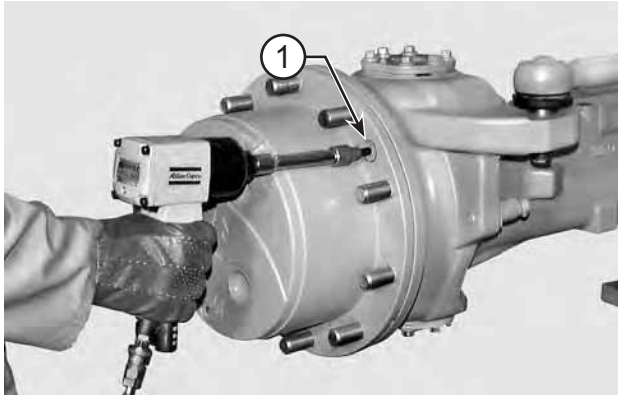

FIGURE 1: Remove screws (1) from planetary cover.

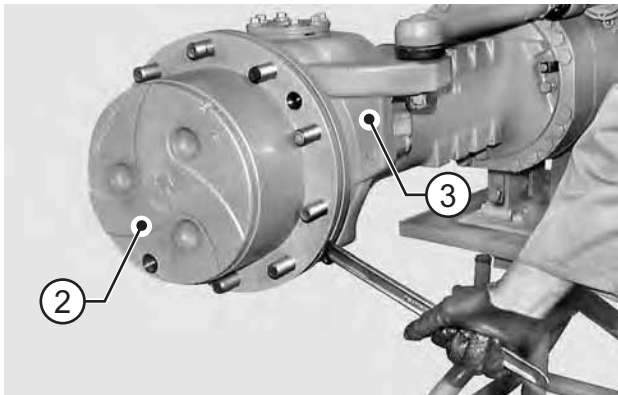

FIGURE 2: Alternately insert a lever in the slots provided and pry to separate the planetary cover (2) from the steering case (3).

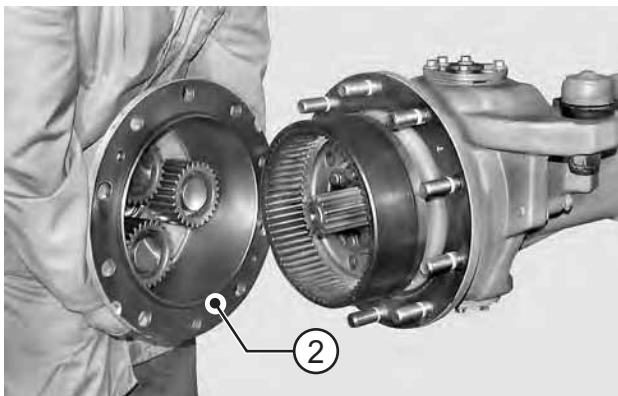

FIGURE 3: Remove the complete planetary cover (2).

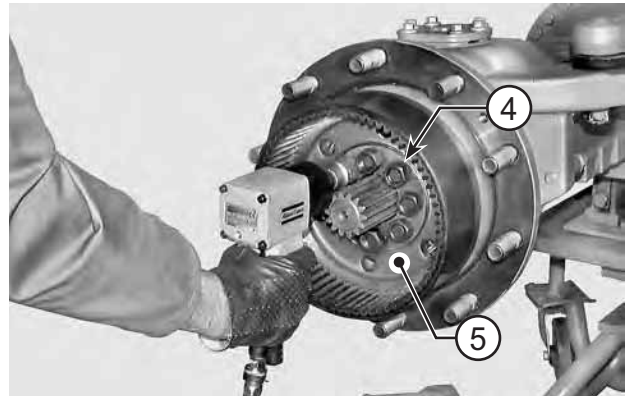

FIGURE 4: Loosen and remove the nuts (4) that lock the ring gear flange (5).

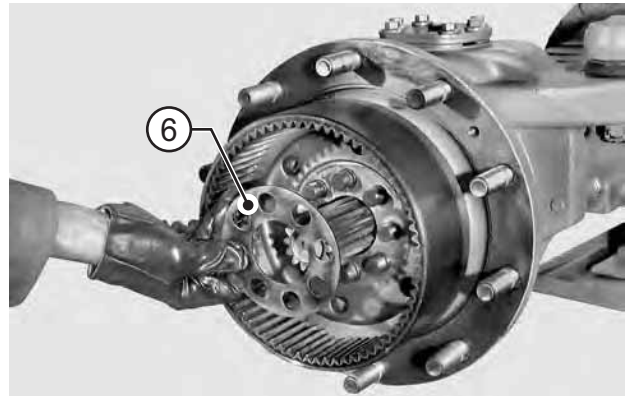

FIGURE 5: Remove safety flange (6).

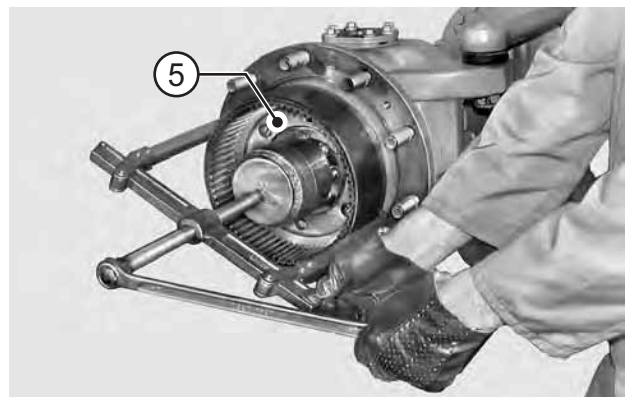

FIGURE 6: Remove the complete ring gear flange (5) by using a puller and applying counter pressure to the studs.

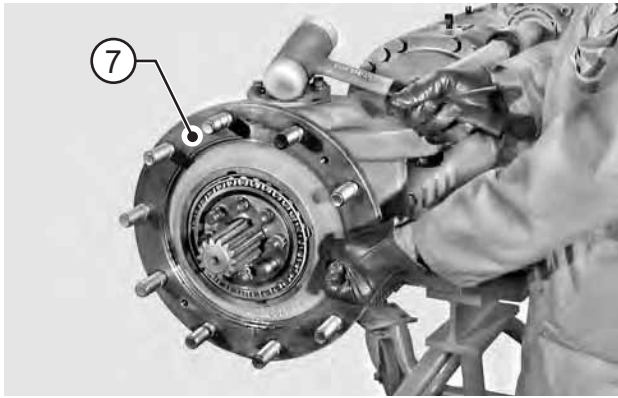

FIGURE 7: Partially draw out the wheel hub (7) by using a plastic hammer.

NOTE:

Hammer alternately on several equidistant points.

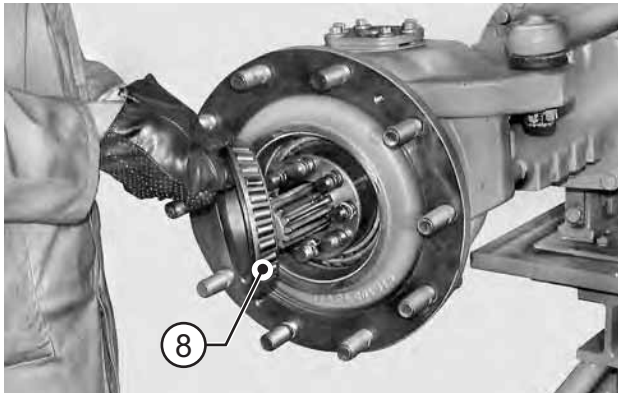

FIGURE 8: Remove the external bearing (8).

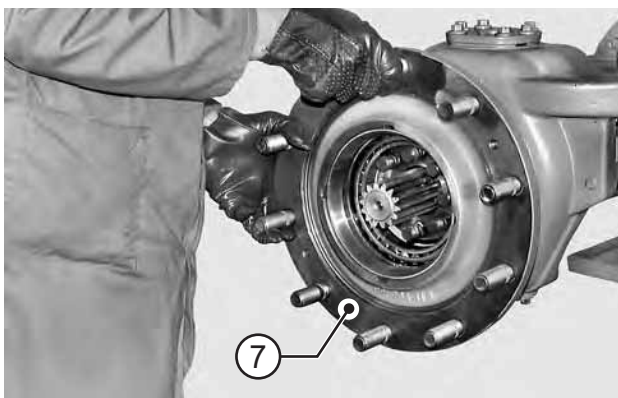

FIGURE 9: Draw out the wheel hub (7).

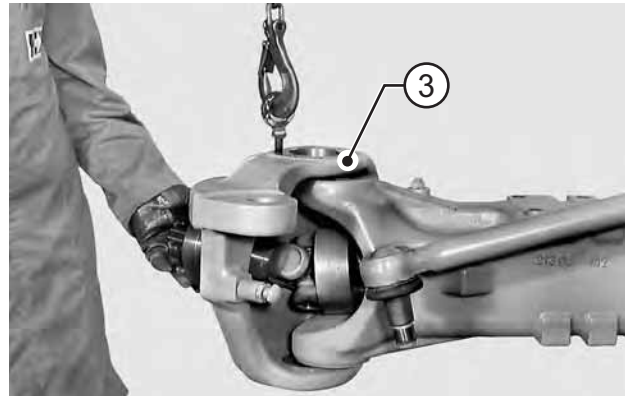

FIGURE 10: Remove the pins and steering case (3). For pin removal details, see COMPLETE STEERING CASE p. 27.

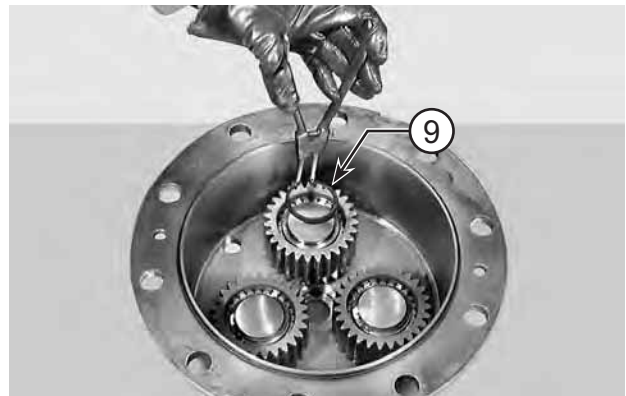

FIGURE 11: Remove the snap rings (9).

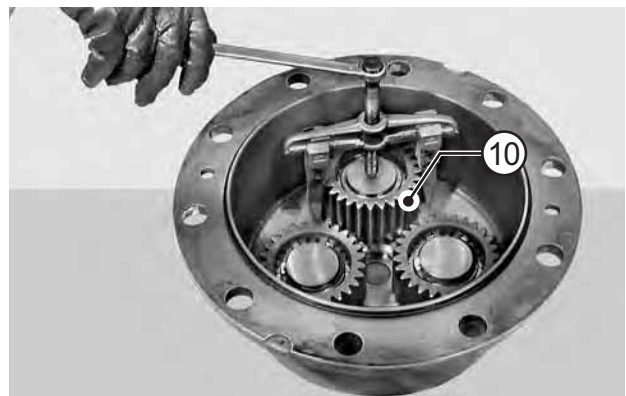

FIGURE 12: Using a puller, remove the planetary gears (10).

NOTE:

Write down direction of installation of planetary gears.

DISASSEMBLY

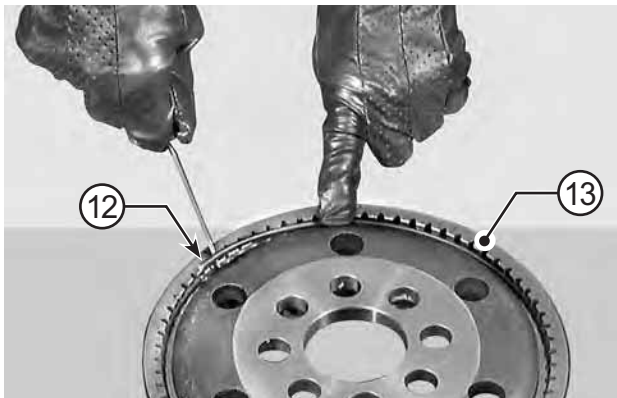

FIGURE 13: Remove the ring gear (13) snap ring (12).

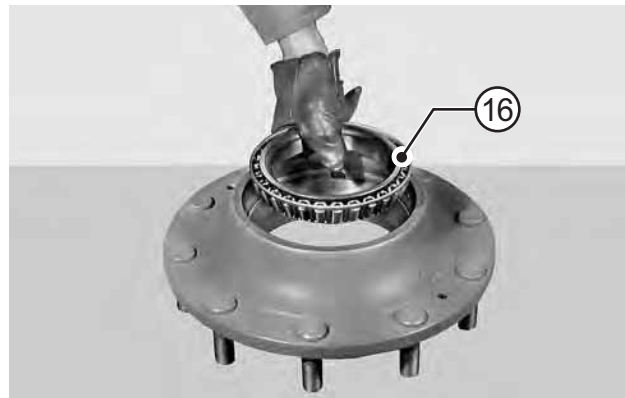

FIGURE 16: Remove inner bearing (16).

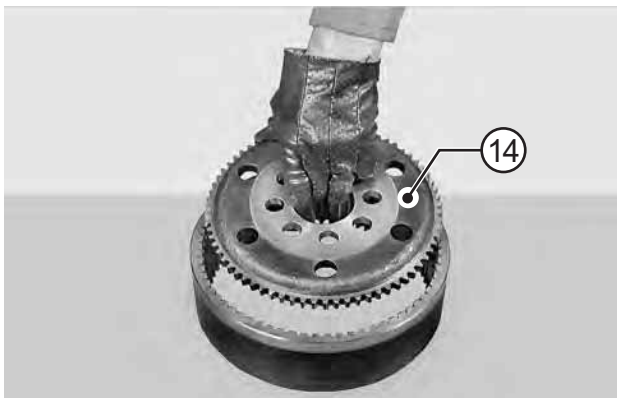

FIGURE 14: Remove ring gear flange (14).

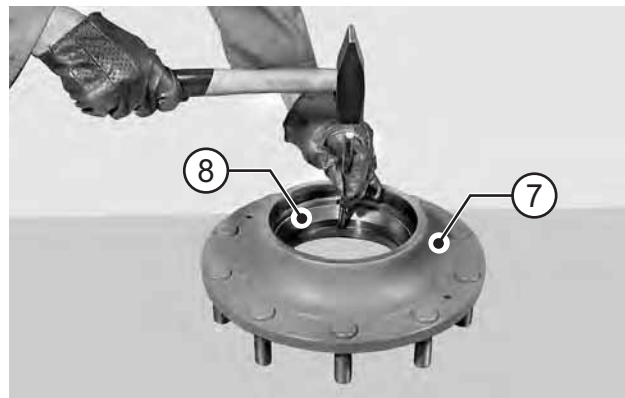

FIGURE 17: Remove the outer thrust blocks of bearings (8) and (16) by inserting and hammering a pin driver in the slots provided on the hub (7).

NOTE:

Hammer alternately to avoid thrust block clamping and deformation.

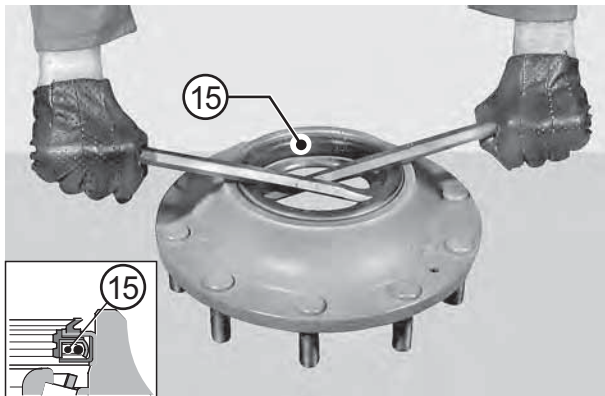

FIGURE 15: Remove seal ring (15) from wheel hub (7).

NOTE:

Mark the seal ring position.

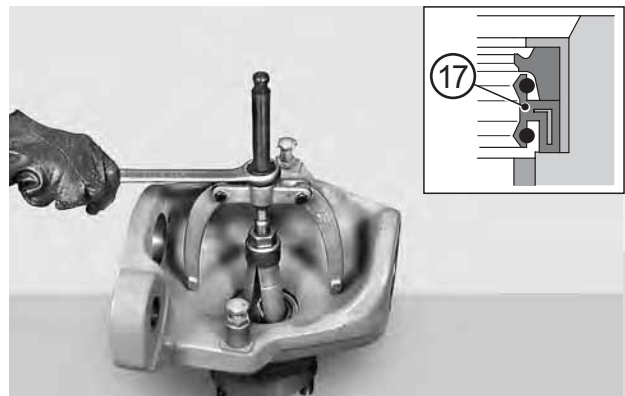

FIGURE 18: Using a puller, remove the seal ring (17) from steering case (3).

NOTE:

Write down seal ring orientation.

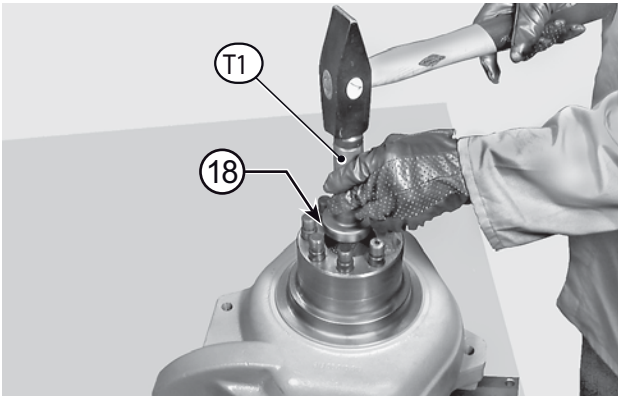

FIGURE 19: Using driver T1 (See drawing T1 p. 57), extract the guide bushing (18) of twin u-joint. Only if necessary, remove any damaged studs (19), which need to be replaced.

ASSEMBLY

ASSEMBLY

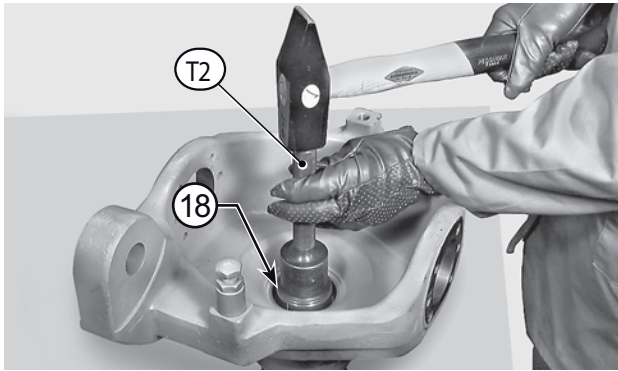

FIGURE 20: Fit the bushing (18) in the steering case (3) using tool T2 (See drawing T2 p. 57).

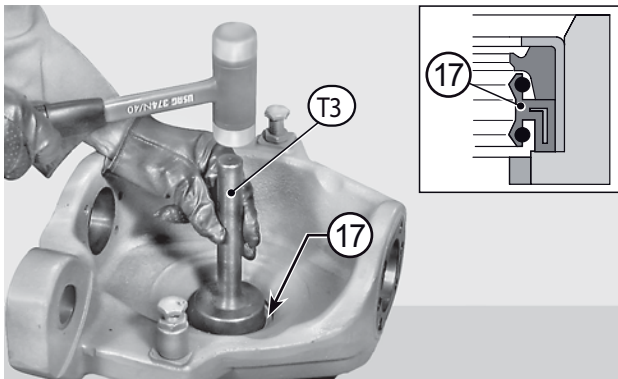

FIGURE 21: Apply a coat of AREXONS rubber cement to the outer metal surface of the snap ring (17). Position the seal ring and, using tool T3 (See drawing T3 p. 58), fit it in the appropriate seat.

CAUTION

Check direction of installation carefully.

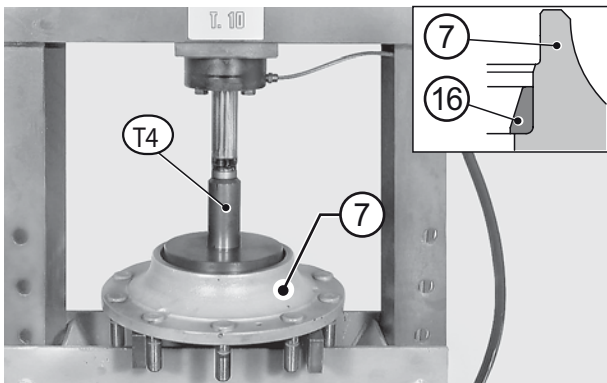

FIGURE 22: Position the wheel hub (7) under a press; lubricate the outer seat of bearing and, using tool T4 (See drawing T4 p. 59), install the thrust block of bearing (16).

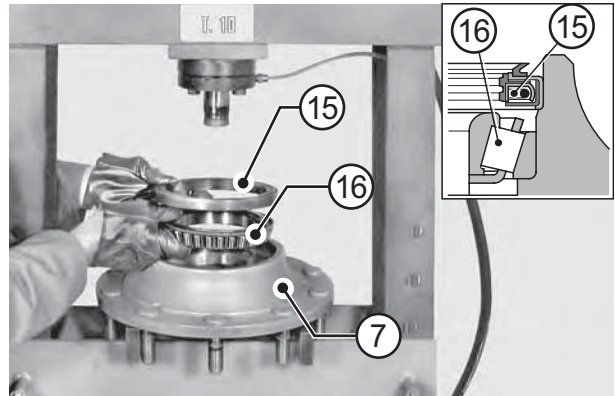

FIGURE 23: Install bearing (16). Apply Arexons seal rubber cement to the outer surface of seal ring (15). Position the seal ring (15) in the hub (7).

CAUTION

Check ring orientation carefully.

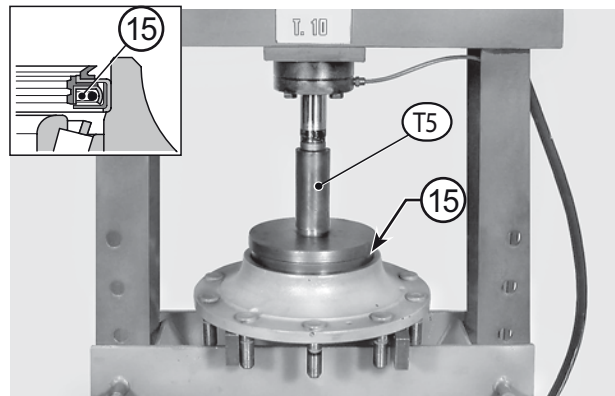

FIGURE 24: Position tool T5 (See drawing T5 p. 60) and press the seal ring (15) into its seat.

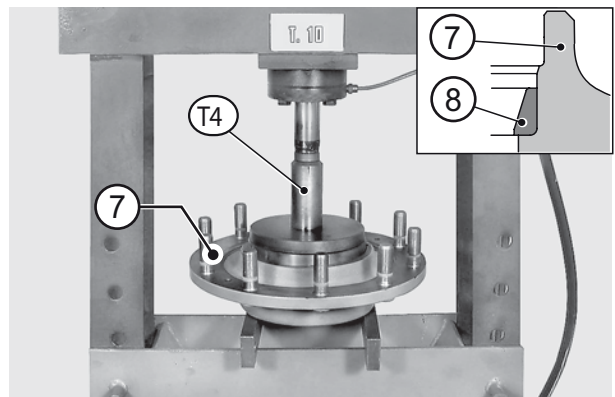

FIGURE 25: Turn the hub over (7), lubricate bearing seat and, using tool T4 (See drawing T4 p. 59) install the thrust block of bearing (8).

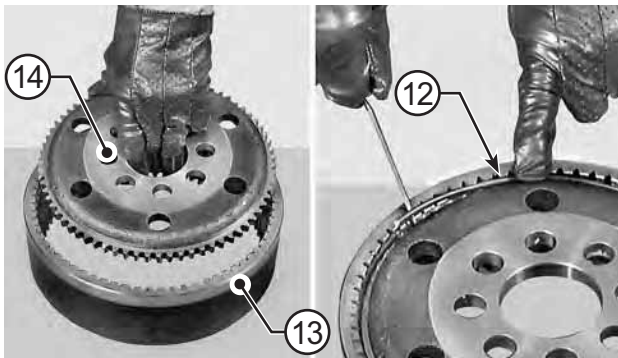

FIGURE 26: Fit the flange (14) in the ring gear (13) and lock into position with snap ring (12).

NOTE:

Check that snap ring (12) is fully inserted in the slot of ring gear (13).

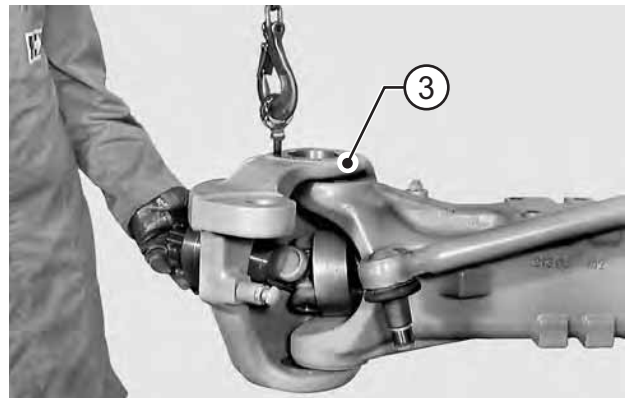

FIGURE 29: Oil the seal ring and bushing. Slip the steering case (3) onto the twin u-joint. Fit the pivot pins and connect the steering bar.

For details, see COMPLETE STEERING CASE p. 27 and STEERING CYLINDER p. 61.

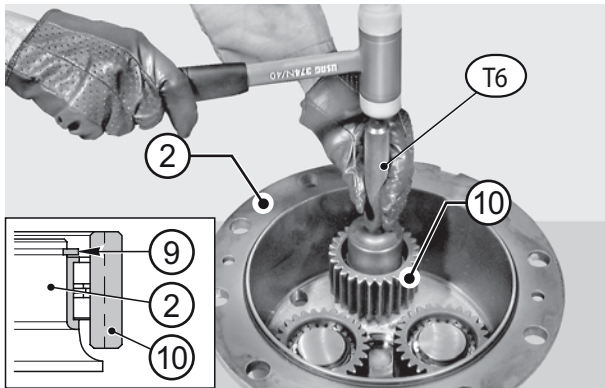

FIGURE 27: Mount gears (10) onto the pins of the planetary cover (2).

To insert gears, use tool T6 (See drawing T6 p. 60).

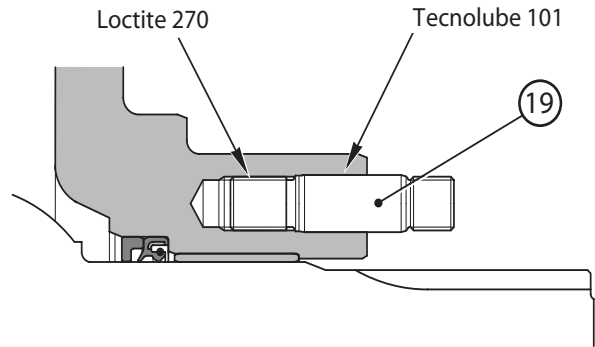

FIGURE 30: Only if studs have been removed, apply a coat of Loctite 270 to the fast end of studs (19) and apply Tec nolube 101 to ground nut end. Tighten studs (19) as far as they will go.

CAUTION

The radiused part of bearings' inner ring must face the bottom of the pin.

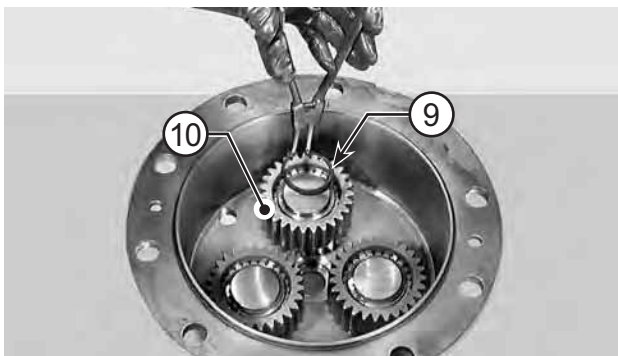

FIGURE 28: Lock gears (10) into position by installing the snap rings (9).



FIGURE 31: Install the wheel hub (7) onto the steering case (3).

ASSEMBLY

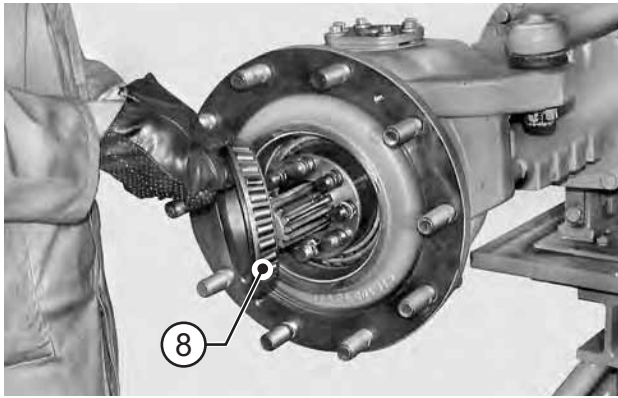

FIGURE 32: Install the outer bearing (8).

NOTE:

Push the bearing as far as it will go by tapping with a plastic hammer all around the rim.

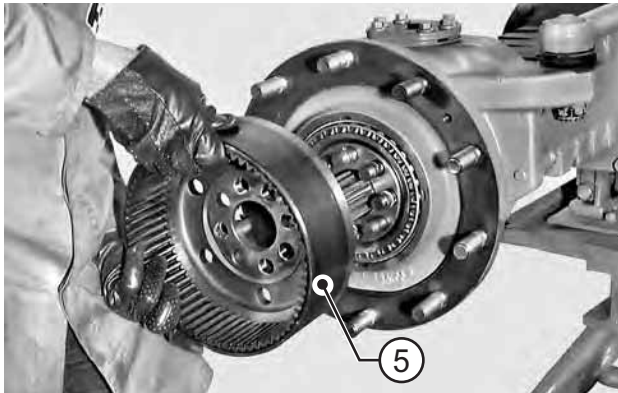

FIGURE 33: Install the complete ring gear flange (5).

NOTE:

To engage the flange (5), use a plastic hammer and hammer alternately on several equidistant points.

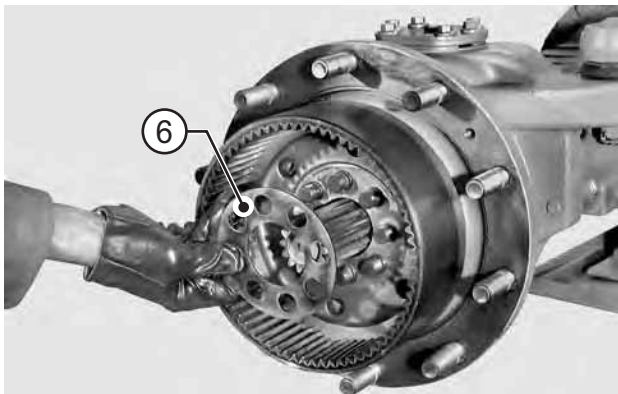

FIGURE 34: Ensure that faces are thoroughly cleaned, and then mount the safety flange (6).

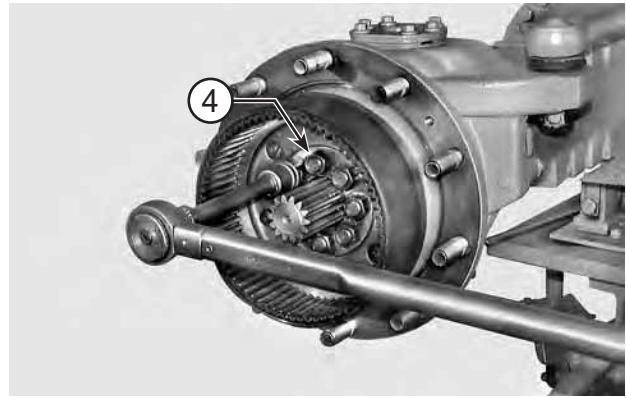

FIGURE 35: Apply Loctite 242 to the studs and tighten nuts (4) in two stages using the criss-cross method. Initial tightening torque: 250 N·m. Final tightening torque: 460 - 465 N·m.

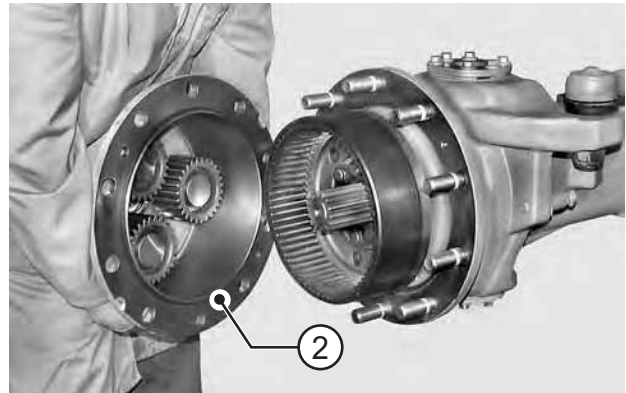

FIGURE 36: Fit the planetary cover (2) on the wheel hub (7).

CAUTION

Check condition and position of o-ring (11).

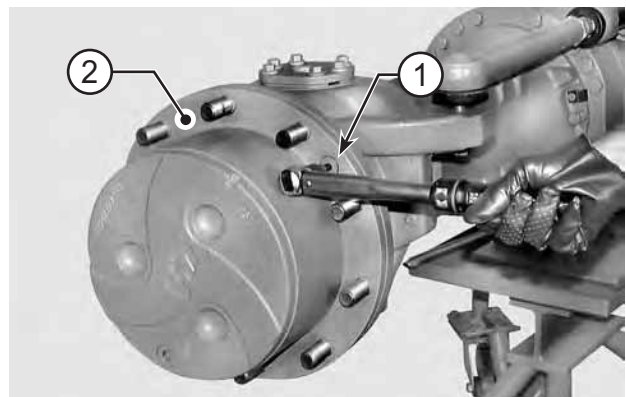
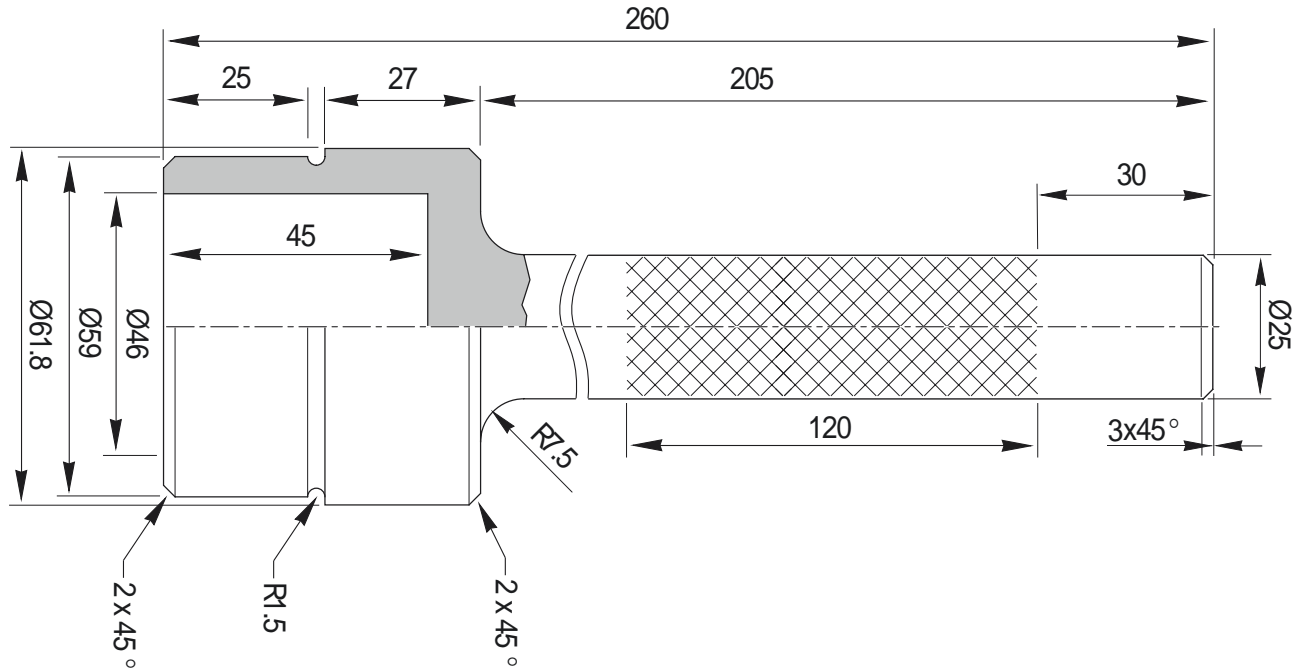

FIGURE 37: Lock the planetary cover (2) with screws (1) to 40 - 50 N·m.

SPECIAL TOOLS

T1

P/N: 2364



T2

P/N: 3348

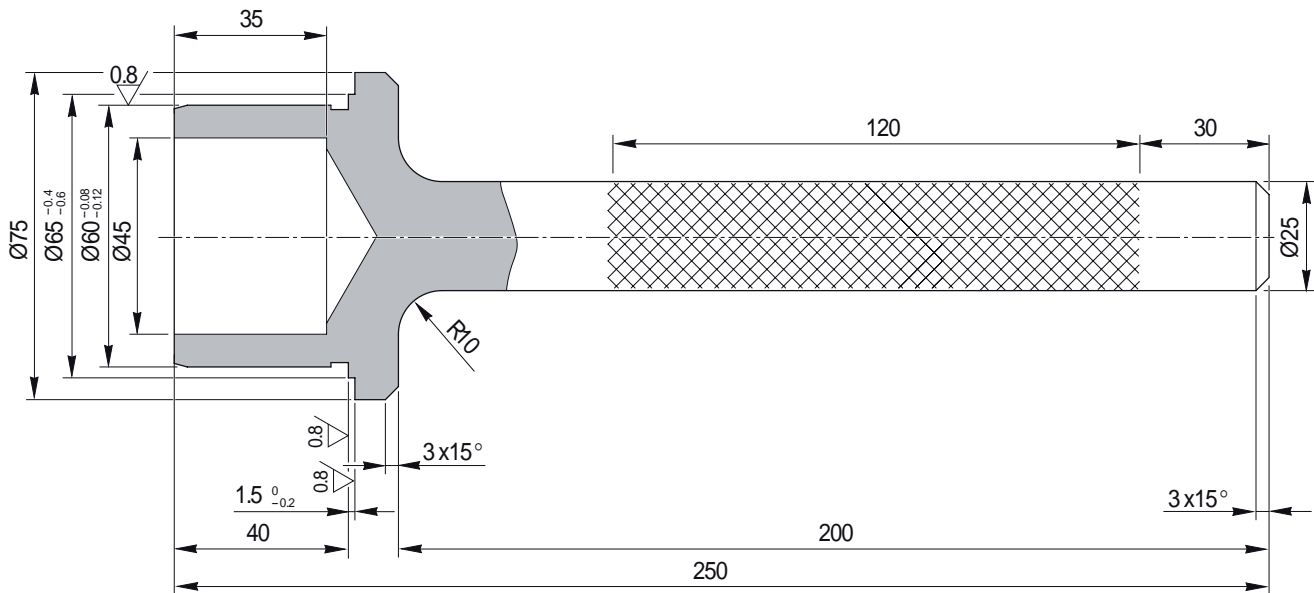

SPECIAL TOOLS

T3

P/N: 2365

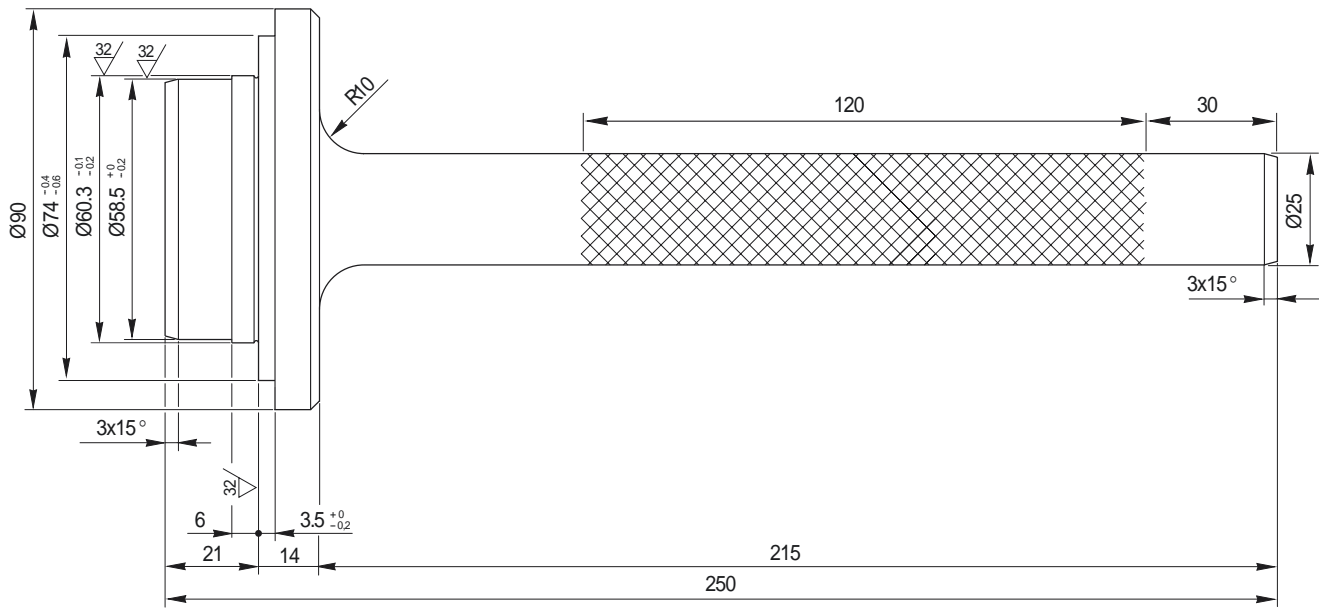

STEERING CYLINDER

EXPLODED VIEW

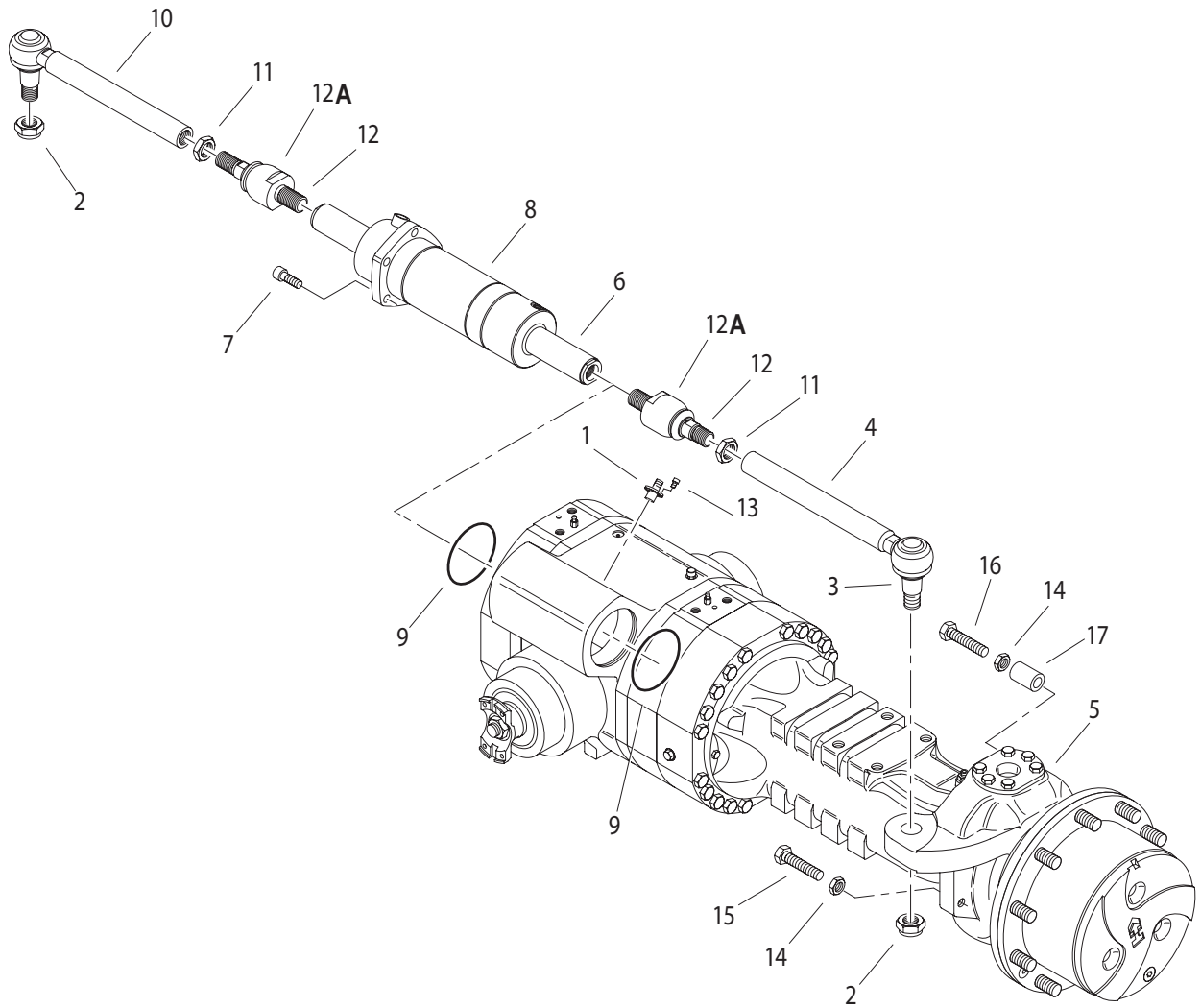

DISASSEMBLY

DISASSEMBLY

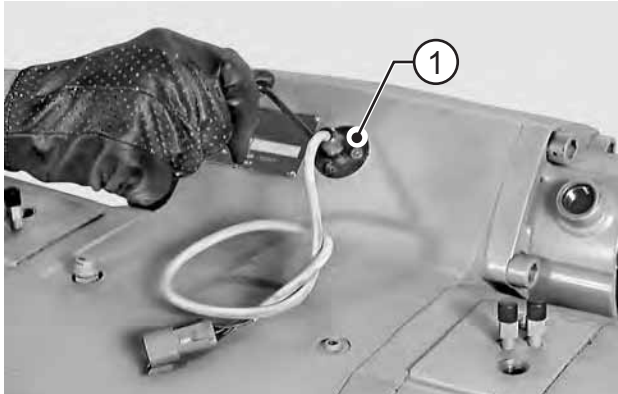

FIGURE 1: If required, remove the steering piston stroke centering sensor (1).

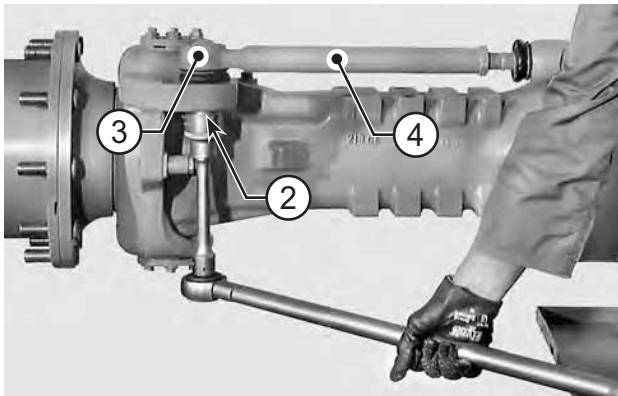

FIGURE 2: Loosen the check nuts (2) on the joints (3) of the steering bars (4) and remove nuts.

NOTE:

Should the joint rotate, hold it with a wrench inserted in the seat provided.

CAUTION

The self-locking nuts (2) must be replaced once every 5 disassemblies.

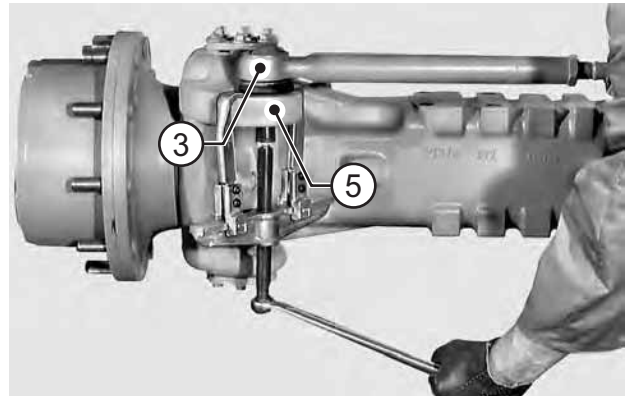

FIGURE 3: Using a puller, disconnect the tapered pins of the joints (3) from the steering cases (5).

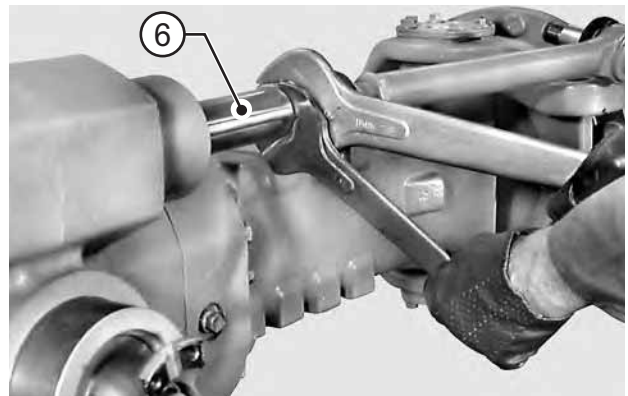

FIGURE 4: Disconnect left and right steering bars from piston (6).

CAUTION

To ease bar removal, heat the threaded portion of the piston to approximately 212 °F [100 °C] with a heat gun.

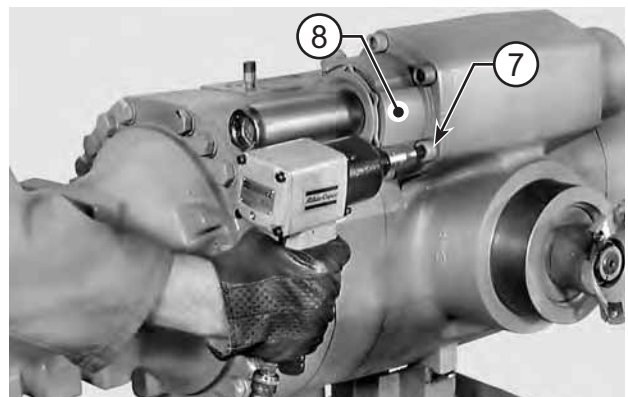

FIGURE 5: Loosen and remove the check screws (7) of steering cylinder (8).

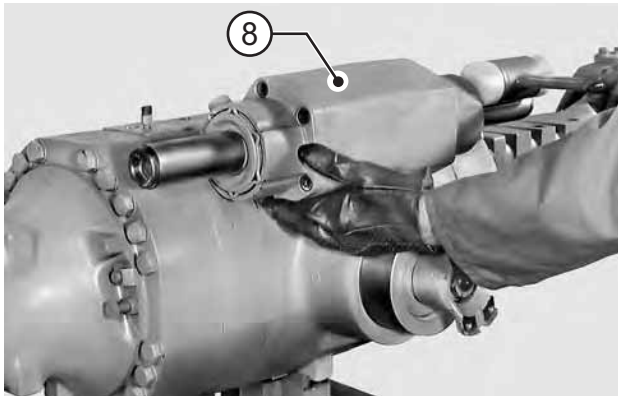

FIGURE 6: Extract the steering cylinder (8) using a plastic hammer.

NOTE:

For cylinder disassembly, see **STEERING CYLINDER** p. 61.

CAUTION

Before attempting to disassemble the unit, drain the oil in the cylinder chambers completely.

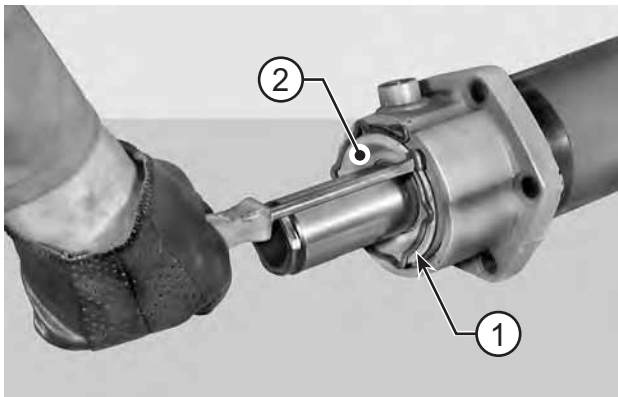

FIGURE 7: Using a screwdriver, remove the cylinder head (2) snap ring (1).

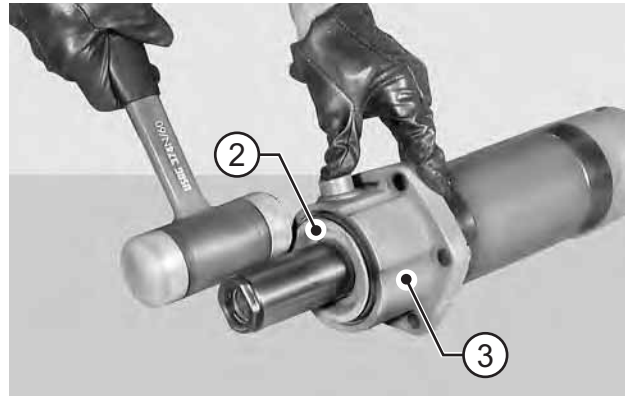

FIGURE 8: Lightly tap the cylinder head (2) with a plastic hammer to push it inside the cylinder (3).

NOTE:

Insert the cylinder head flush with the cylinder.

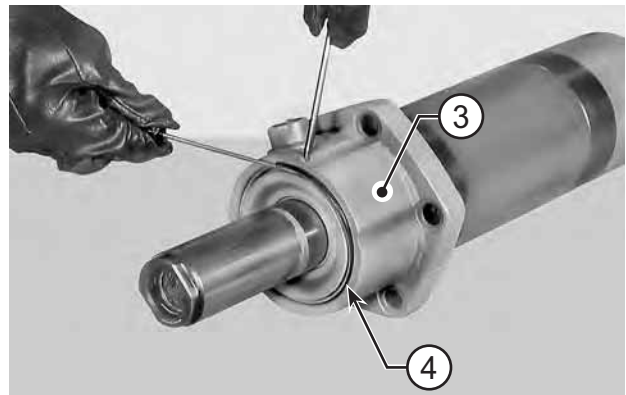

FIGURE 9: Using a punch, force the stop ring (4) located inside the cylinder (3) and extract ring using a screwdriver.

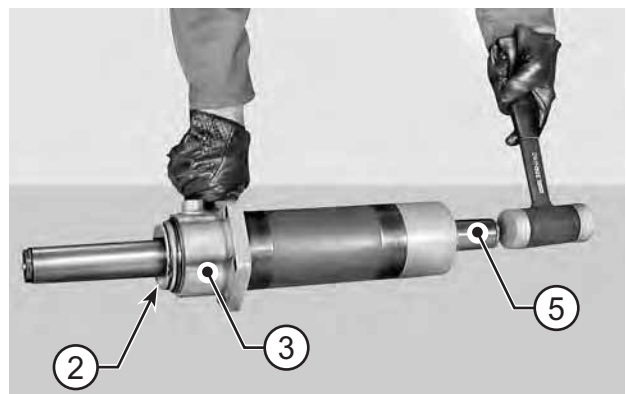

FIGURE 10: Using a plastic hammer, hammer the piston (5) so it strikes against the head (2). Continue until the head (2) is ejected from the cylinder (3).

DISASSEMBLY

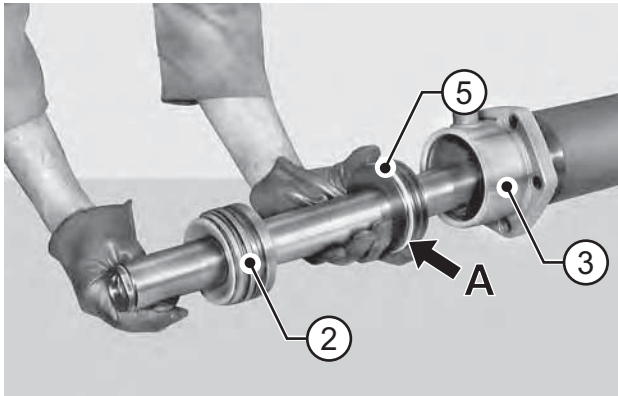

FIGURE 11: Take the cylinder unit (3) apart by extracting the head (2) first, followed by the piston (5). Remove all seals, anti-extrusion rings, and scraper rings from head (2), cylinder (3), and piston (5).

⚠ CAUTION

During disassembly document the direction of seal ring "A" on the piston (5) as some models are assembled differently.

📌 NOTE:

- 1 - All seals must be replaced at each disassembly.**
- 2 - Pay particular attention not to damage seal seats and piston beds.**

ASSEMBLY

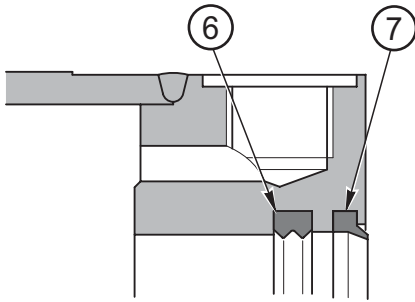

FIGURE 12: Grease and install the piston rod seal ring (6) and scraper ring (7) into cylinder (3).

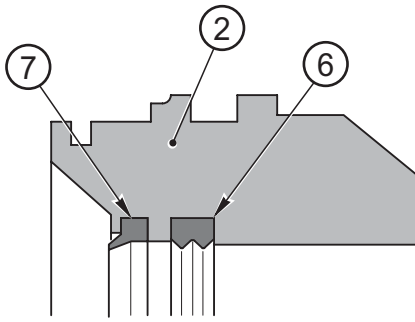

FIGURE 13: Grease and install the piston rod seal ring (6) and scraper ring (7) into the head (2).

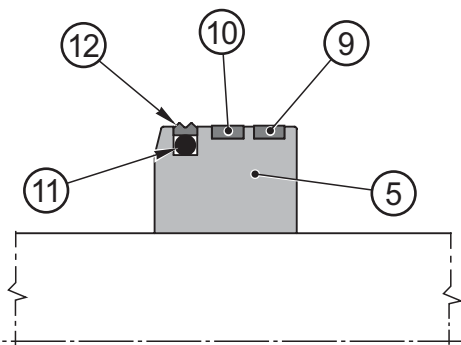

FIGURE 14: Fit seal (8) on the outside of the head (2).

CAUTION

- 1 - To ease installation, grease the outer surface of the piston.
- 2 - Do not roll the seal (8).

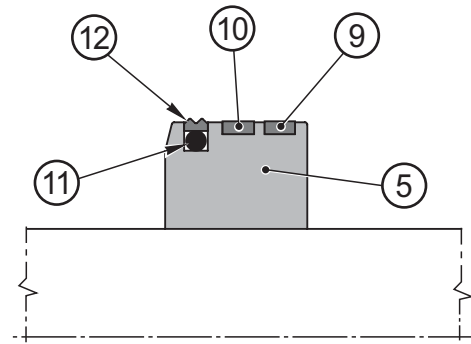

FIGURE 15: Prepare piston (5) by fitting it with guide ring (9), magnetic ring (10), o-ring (11), and seal (12).

CAUTION

- 1 - To ease installation, lubricate with grease.
- 2 - If a centring sensor is not required, the magnetic ring (10) can be replaced with an additional guide ring (9).

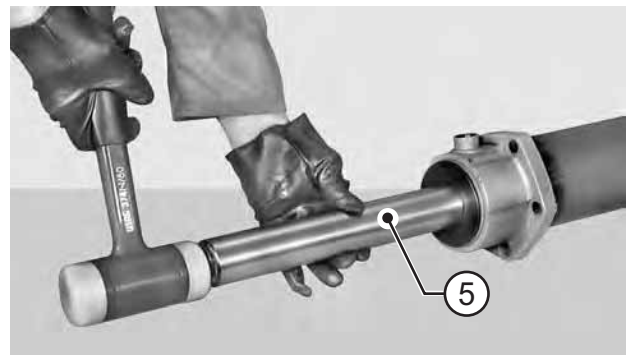

FIGURE 16: Install the piston (5) into the cylinder approximately 150 mm using a plastic hammer.

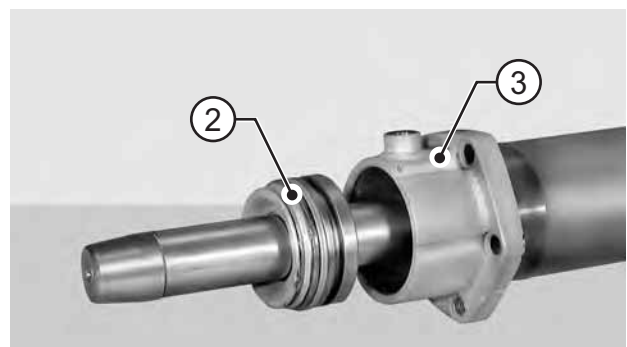

FIGURE 17: Grease the seals of the head (2). Slip the head onto the piston and, using a plastic hammer, introduce head into cylinder (3).

NOTE:

Install the head flush with the cylinder.

ASSEMBLY

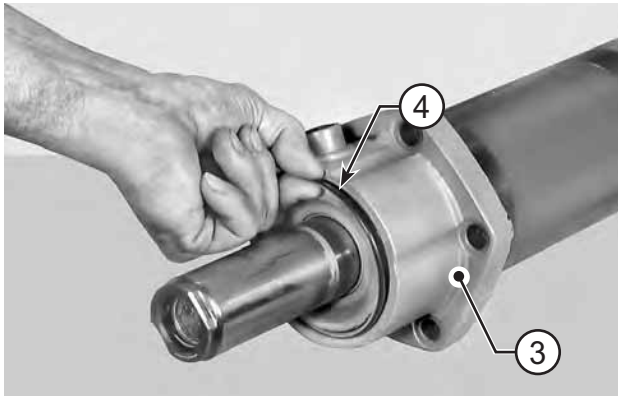

FIGURE 18: Install the stop ring (4) and ensure that it sets in the seat of cylinder (3).

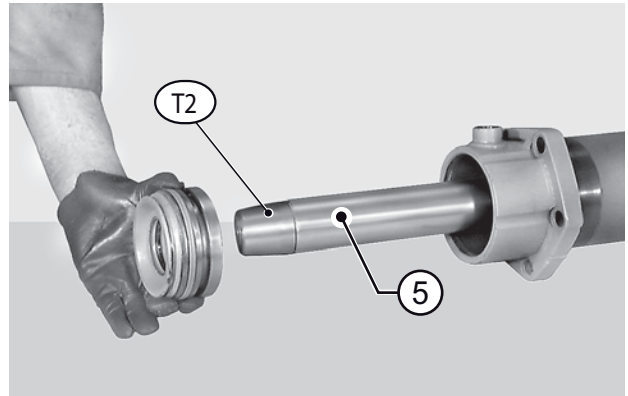

FIGURE 21: Remove tool T2 (See drawing T2 p. 71) and apply it to the opposite side of the piston (5).

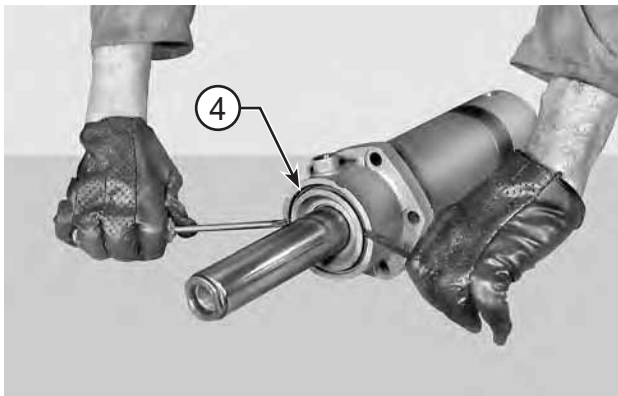

FIGURE 19: Using two screwdrivers or levers, force the head until it is seated against the stop ring (4).

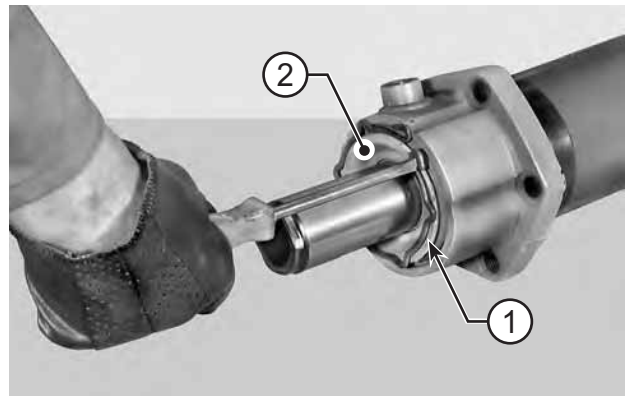

FIGURE 22: Install the snap ring (1) of head (2). If necessary, force it into the seat with a punch and hammer.

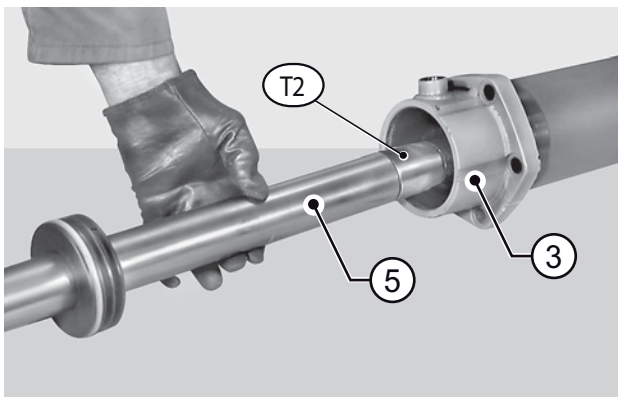

FIGURE 20: Apply tool T2 (See drawing T2 p. 71) to the piston rod on non-head side (2) and center rod into cylinder (3) to fit it into piston (5).

NOTE:

Lightly grease seals and cylinder.

CAUTION

Make sure the snap ring (1) fits snugly in its seat.

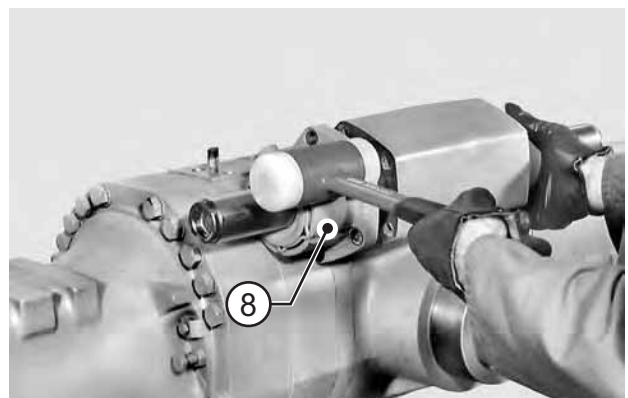

FIGURE 23: Check the condition of the axle unit's o-rings (9). Grease piston seats with TecnoLube Seal 101 and install cylinder using a plastic hammer.

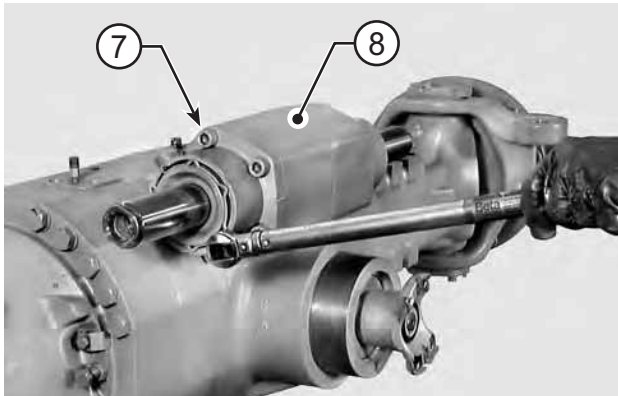

FIGURE 24: Block cylinder (8) with screws (7) coated with Loctite 242 and tighten to 180 - 200 N·m.

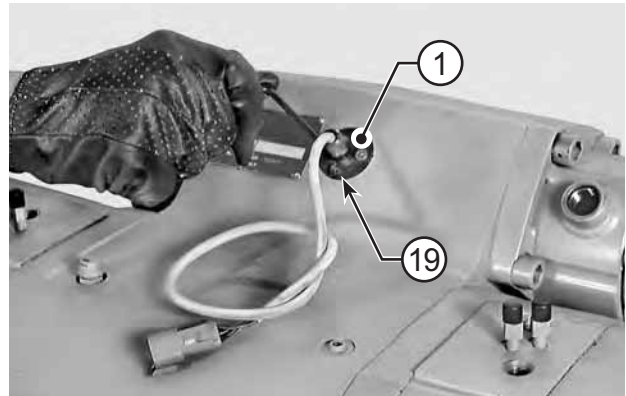

FIGURE 27: If required, install the steering piston stroke centering sensor (1) and tighten screws (13) to 5 - 6 N·m

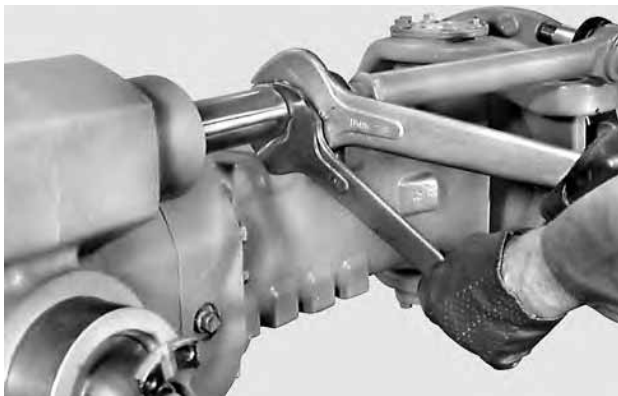

FIGURE 25: Apply Loctite to the threaded portion of the steering bars and connect the bars by tightening the ends in the piston rod. Tightening torque: 430 - 470 N·m.

⚠ CAUTION

If required, eliminate the action of the negative brake.

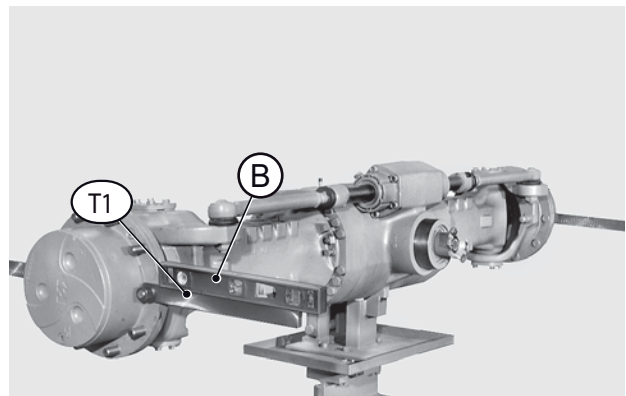

FIGURE 28: Apply tools T1 (See drawing T1 p. 71) onto the wheel hubs and lock tools. Check that tools are perfectly flat and parallel to each other using a level "B".

⚠ CAUTION

Remove grease from the threads using an activator before applying the thread locking compound.

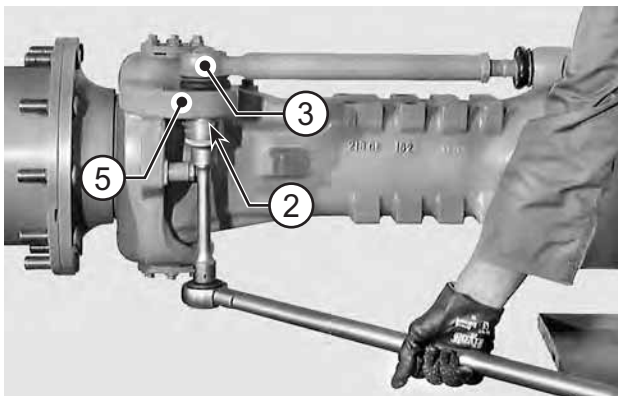

FIGURE 26: Introduce the pins (3) in the steering cases (5) and lock into position with nuts (2) tightened to a torque of 350 - 390 N·m.

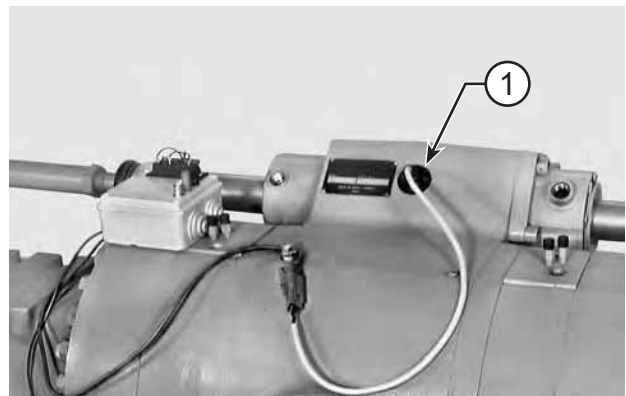

FIGURE 29: Connect the sensor (1) to the control device according to either of the following diagrams.

ASSEMBLY

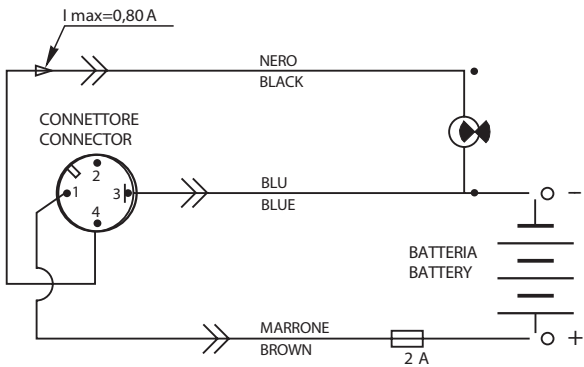

FIGURE 30: Sensor wiring diagram for STANDARD version.

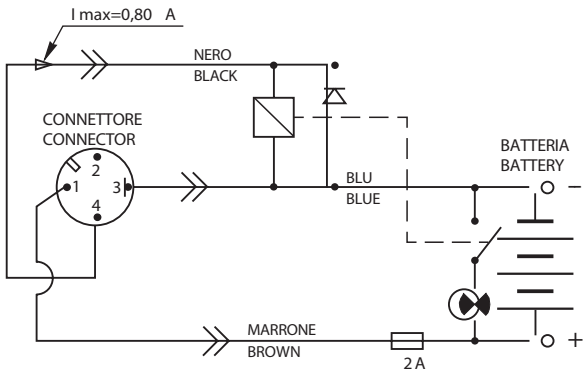

FIGURE 31: Sensor wiring diagram for OPTIONAL version.

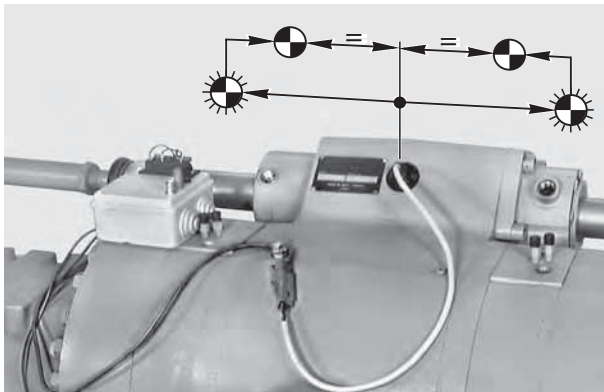

FIGURE 32: Center by slowly moving the piston first in one direction, then in the opposite one. Position the piston in the middle point of the stroke, which is determined by the control device signalling lamp turning on and switching off in the reverse stage.

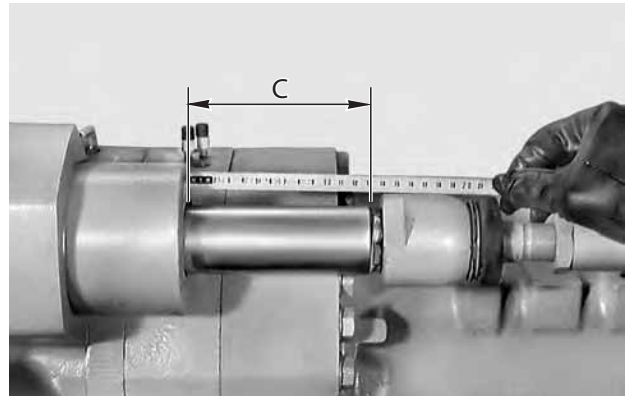

FIGURE 33: Check distance "C" of piston on either of the two sides and write down distance dimension to check subsequent adjustments.

NOTE:

For cylinders without sensors, piston must be centered based on maximum stroke.

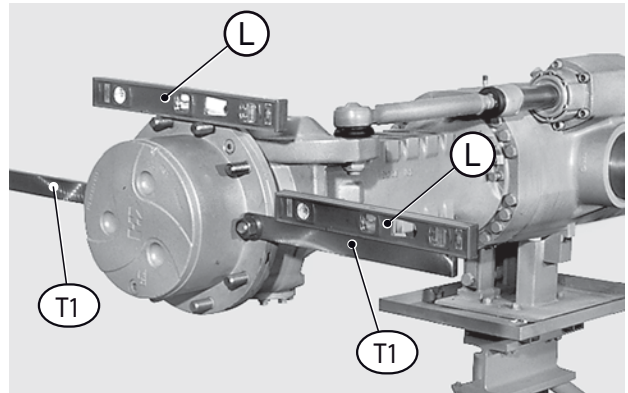

FIGURE 34: Lay level "L" on two upper studs and line them up. Apply tools T1 (See drawing T1 p. 71) to the two horizontal studs; hold them in position with two nuts, level them, and finally lock into position.

CAUTION

Make sure that tools T1 (See drawing T1 p. 71) perfectly adhere to wheel face.

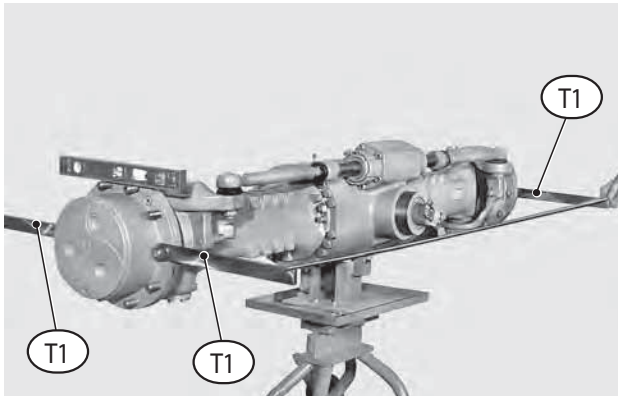

FIGURE 35: Without moving the piston, check front and rear distance between the edges of tools T1 (See drawing T1 p. 71) Maximum allowed difference: 1 - 1.5 mm.

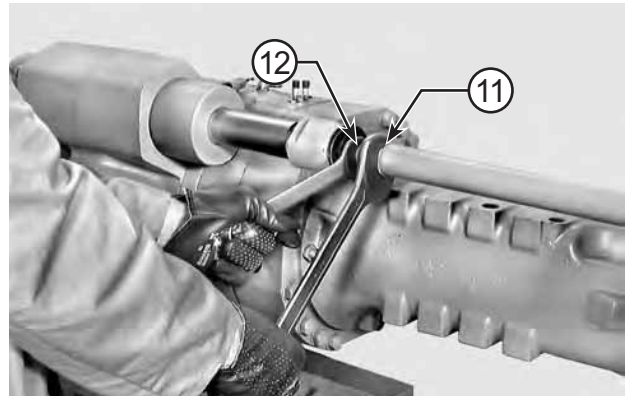

FIGURE 38: Once toe-in has been adjusted, lock nuts (11). Tightening torque for nuts: 328 - 363 N-m.

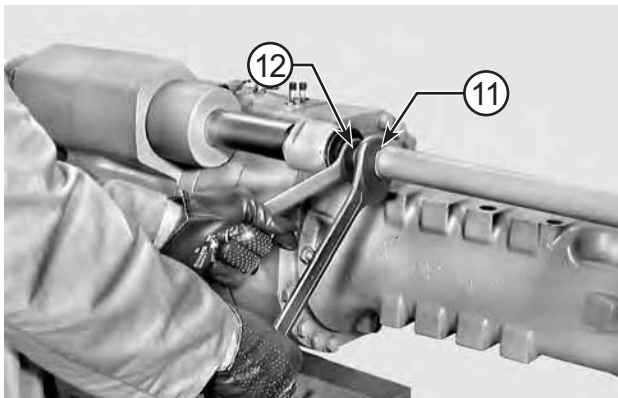

FIGURE 36: TOE-IN
If necessary, adjust alignment after loosening the check nuts (11) of ball pins (12).

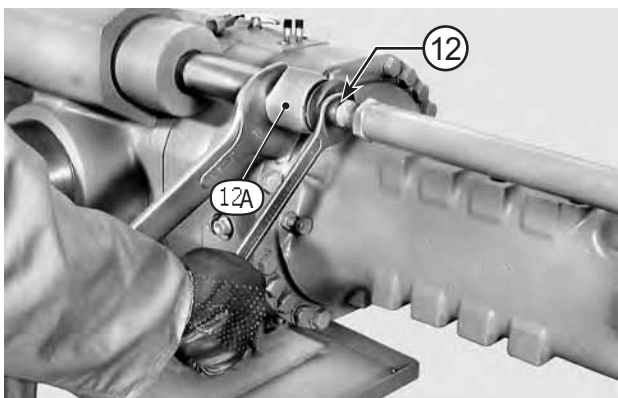

FIGURE 37: Hold joints (12A) tight and rotate the ball pins (12) until tools T1 (See drawing T1 p. 71) become parallel to each other.

NOTE:

- 1 - Loosen the nuts by a few turns.
- 2 - Half a turn of the pin will reduce the front distance by about 3 mm and increase the rear one by about 3 mm.

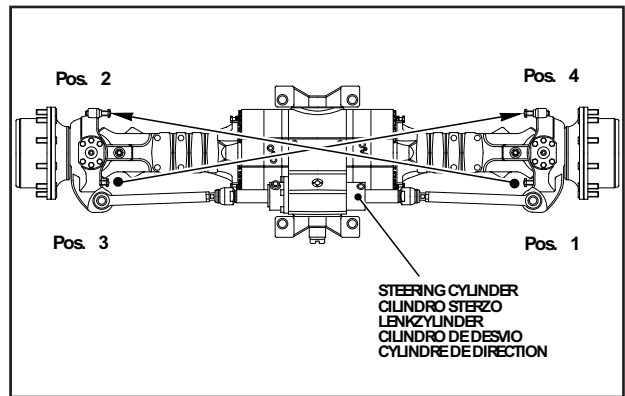

FIGURE 39: ADJUSTING THE STEERING ANGLE
Loosen the nut of one of the adjusting screws on cylinder side.

NOTE:

Perform the same operations on both sides (see diagram).

STEERING ANGLE - ANGOLO DI STERZATURA - EINSCHLAGWINKEL - ANGULACION DE DESVIO - ANGLE DE BRAQUAGE	43°	45°	35°	55°	40°	50°	
DISTANCE - DISTANZA - ABSTAND - DISTANCIA - DISTANCE	"B" (mm)	58.5	53.5	51.6	23.8	36.6	38.2

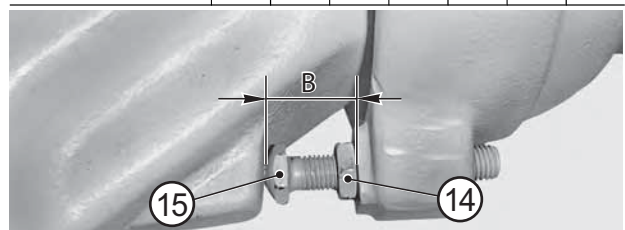

FIGURE 40: Adjust the jutting portion of the screw (15) according to data shown in the table. Lock into position with nut (14) tightened to 145 - 148 N-m.

ASSEMBLY

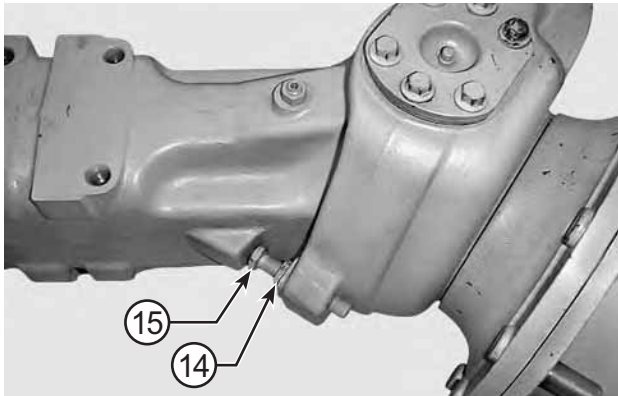

FIGURE 41: Perform one full steering operation until the adjusted screw (15) leans against the arm stop.

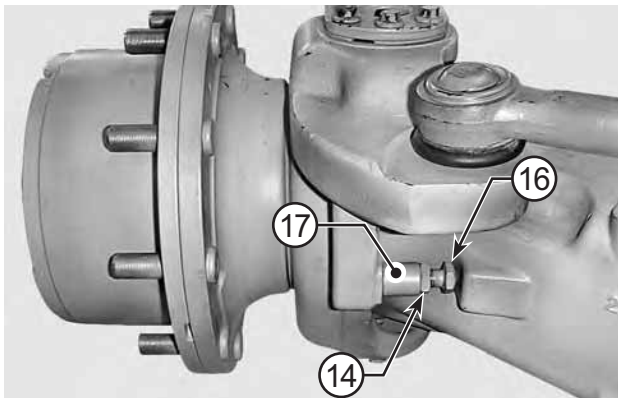

FIGURE 42: While holding the adjustment screw in position against the arm stop, adjust the screw opposite (16), on non-cylinder side, until it leans against the arm stop.

⚠ CAUTION

The screws (15) and (16) must lean against the respective arm stops all at the same time.

DIFFERENTIAL UNIT

EXPLODED VIEW

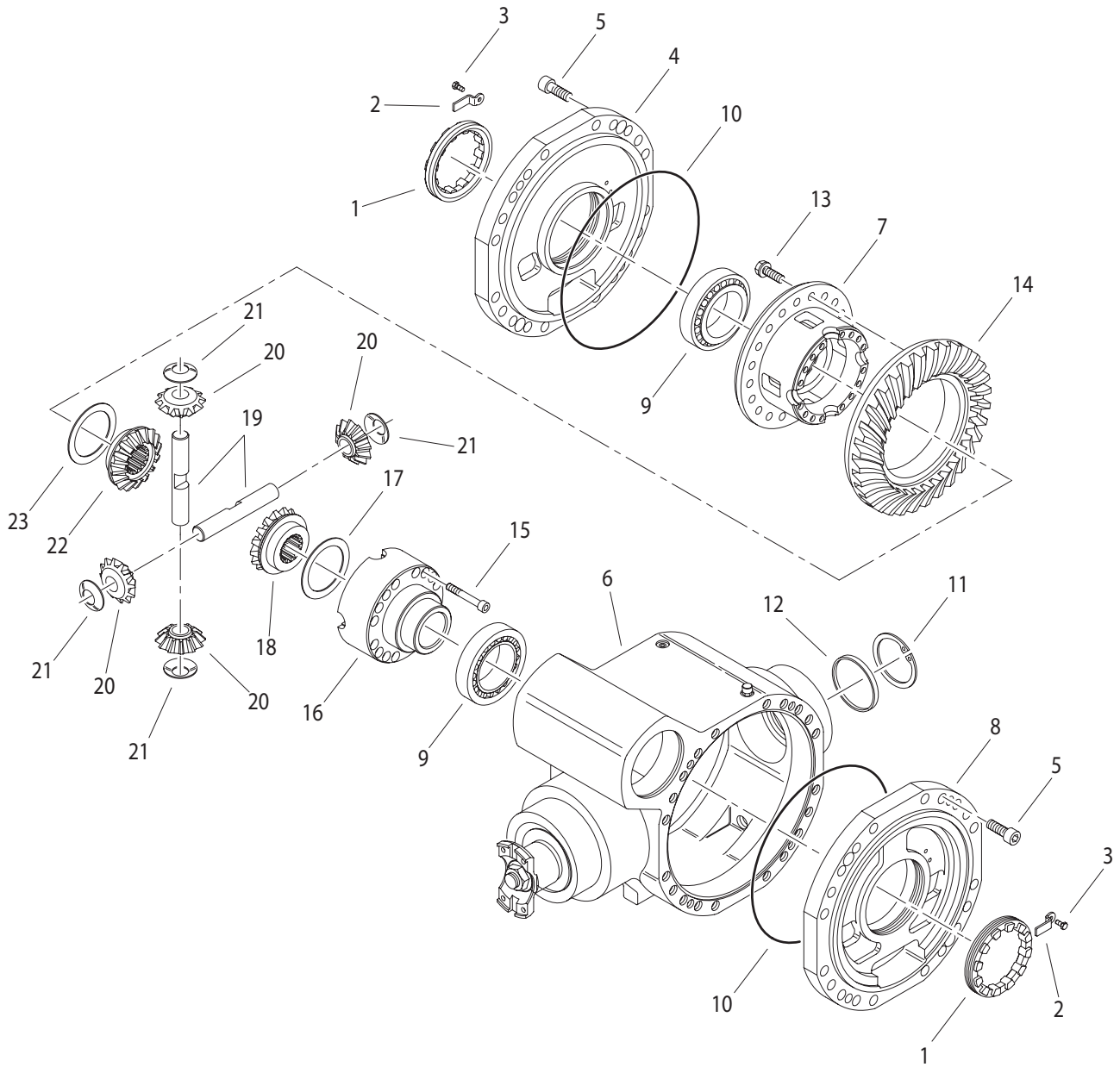

DISASSEMBLY

DISASSEMBLY

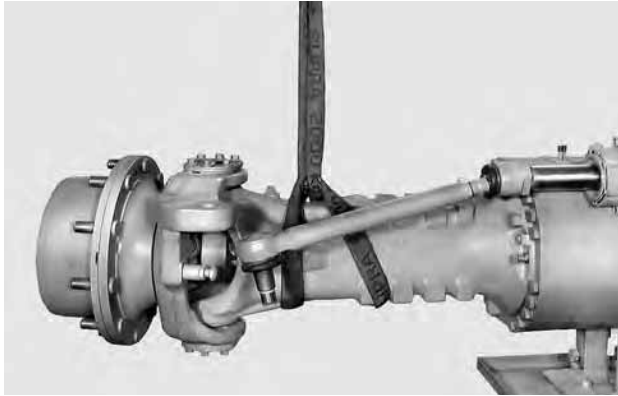

FIGURE 1: Remove the entire arms and negative brake cylinders. For details, see CHECKING WEAR AND REPLACING THE BRAKING DISCS p. 17.

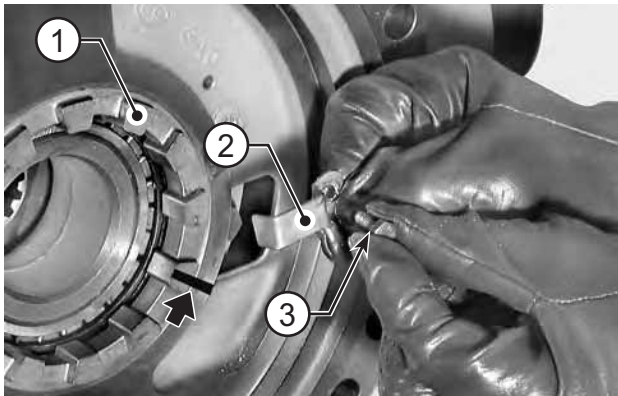

FIGURE 2: Only if removing or adjusting is needed, mark the position of the ring nuts (1). Remove screws (3) and ring nut checks (2).

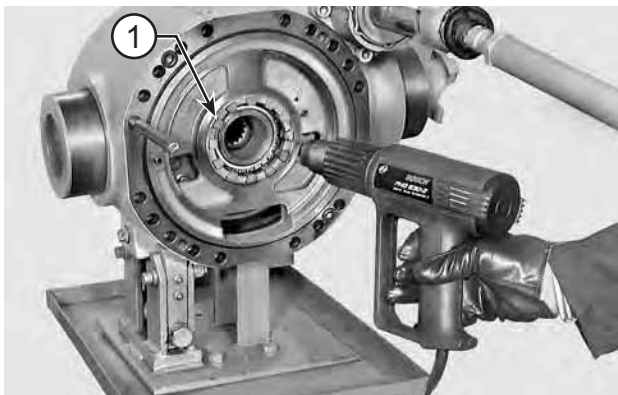

FIGURE 3: Only if removing or adjusting is needed, heat the ring nuts (1) uniformly to a temperature of about 176 °F [80 °C].

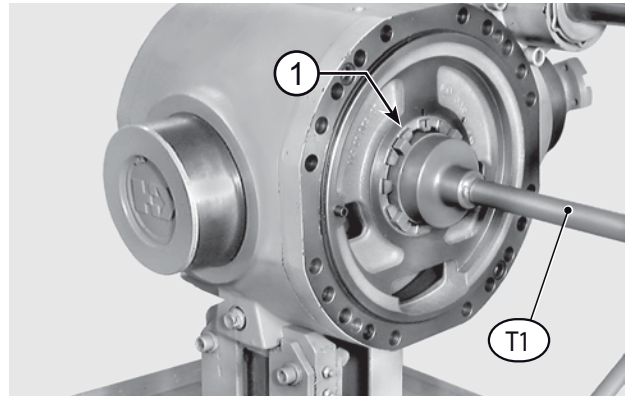

FIGURE 4: Only if removing or adjusting is needed, use tool T1 (See drawing T1 p. 83) to loosen and remove the ring nuts (1).

NOTE:

Remove any trace of sealant from the ring nuts threads and intermediate covers.

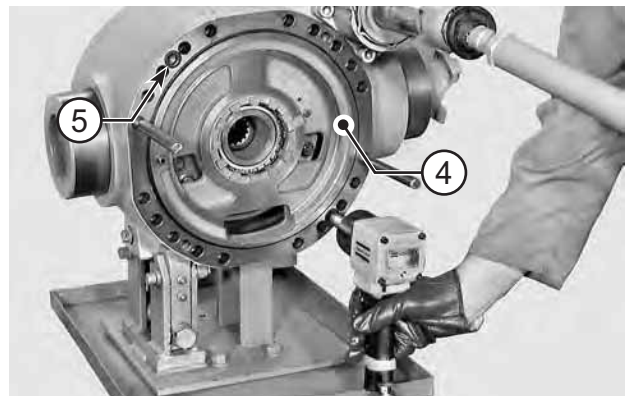

FIGURE 5: Tighten two safety M16 studs in the main body. Loosen and remove the check screws (5) of intermediate cover (4) on ring gear side.

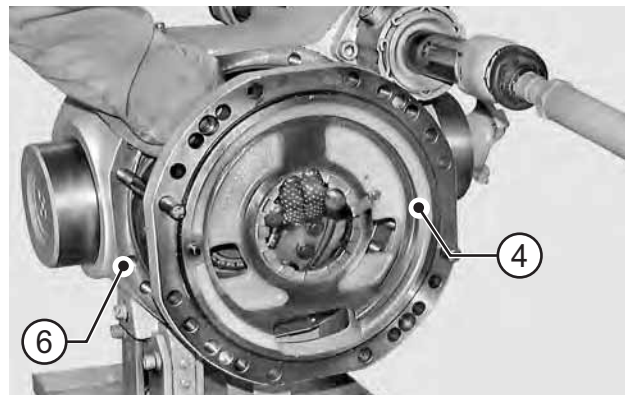

FIGURE 6: Support the differential unit and separate the intermediate cover (4) from the main body (6). Remove cover (4).

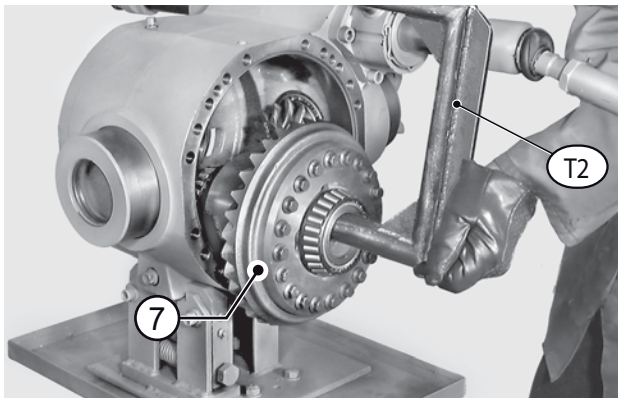

FIGURE 7: Remove the differential unit (7) and place it on a workbench.

NOTE:

Use the tool T2 (See drawing T2 p. 84) to ease removal.

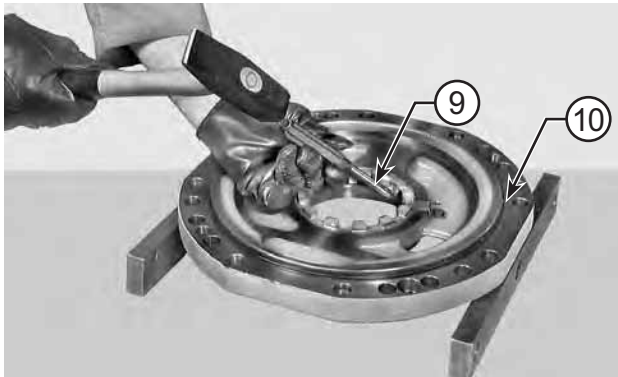

FIGURE 8: If bearings need replacing, remove the outer thrust blocks of bearings (9) from intermediate covers (4) and (8).

NOTE:

Carefully check the o-rings (10).

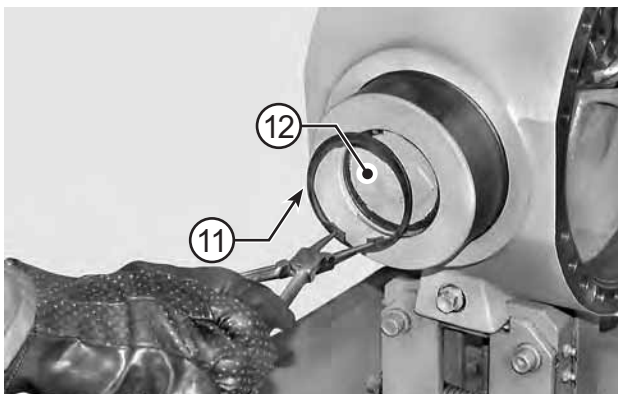

FIGURE 9: Remove snap ring (11) and cap (12).

NOTE:

Replace cap at each disassembly.

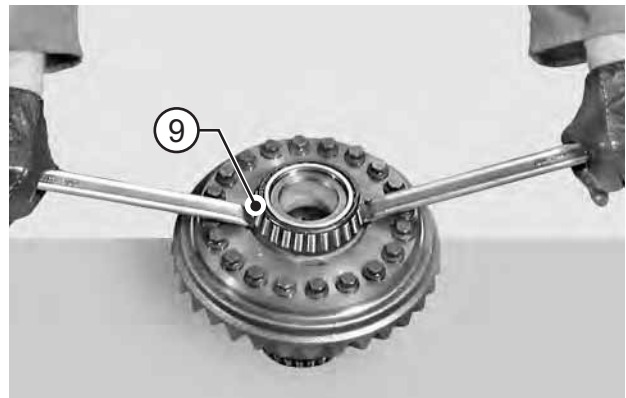

FIGURE 10: DISASSEMBLY

Using two levers, lift bearing (9) on ring gear side by about 8 mm.



FIGURE 11: Loosen and remove the check screws (13) of ring gear (14).

NOTE:

The screws must be replaced at each disassembly.



FIGURE 12: Remove the ring gear (14).

NOTE:

If necessary, use a plastic hammer.

DISASSEMBLY

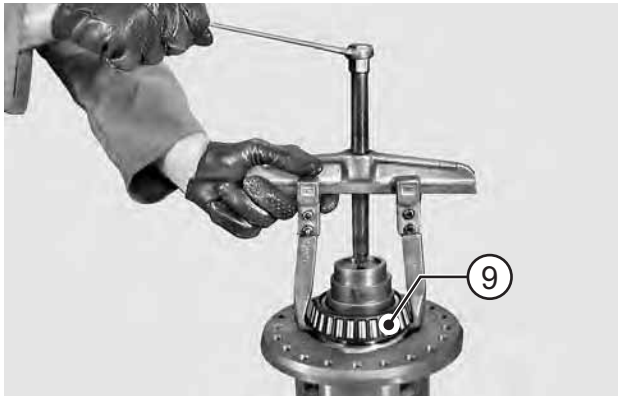

FIGURE 13: Using a puller, remove bearings from ring gear (9) side.

NOTE:

Fit puller in connection with the slots provided.



FIGURE 14: Using a separator and a puller, remove bearing from non-ring gear side.

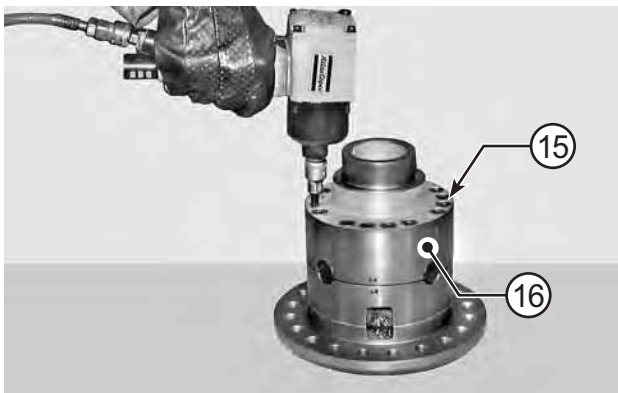

FIGURE 15: Loosen and remove check screws (15) from differential box (16).

NOTE:

The screws must be replaced at each disassembly.

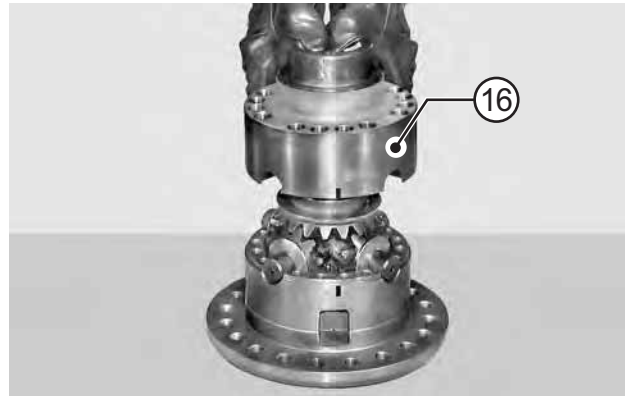

FIGURE 16: Remove the half-box (16).

CAUTION

Mark reference marks for joining the two halves.

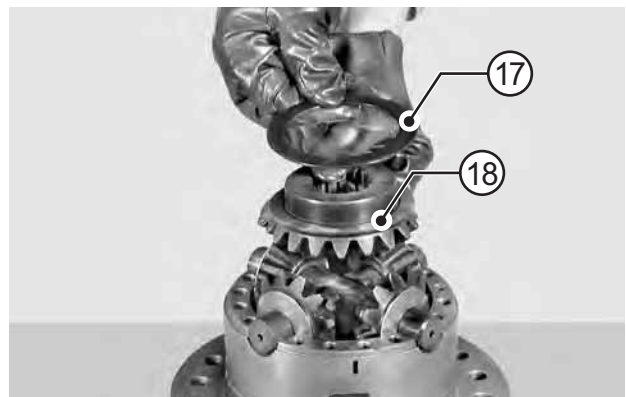

FIGURE 17: Remove shoulder (17) and first planetary gear (18).

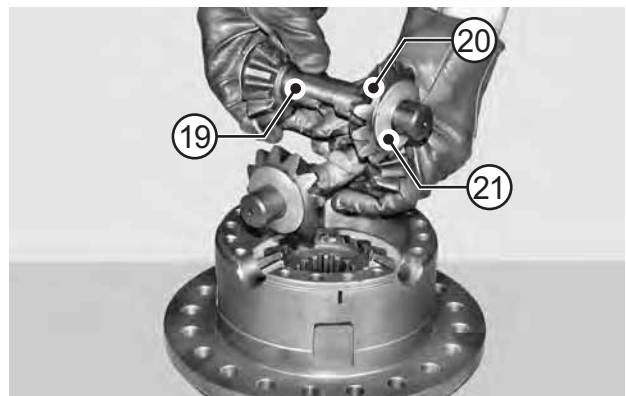

FIGURE 18: Remove shafts (19), complete with planetary gears (20) and spherical shoulder washers (21).

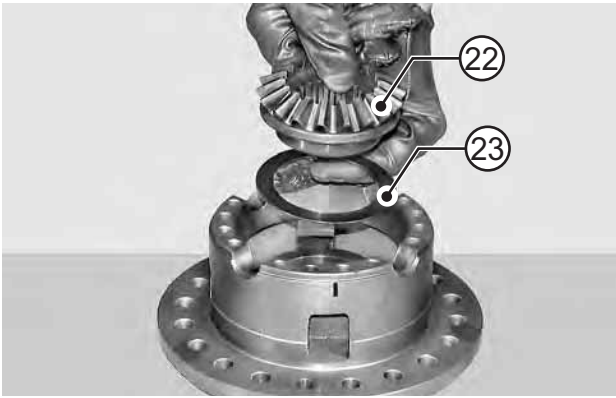

FIGURE 19: Remove the 2nd planetary gear (22) and shoulder ring (23).

INSTALL AND ADJUST

INSTALL AND ADJUST

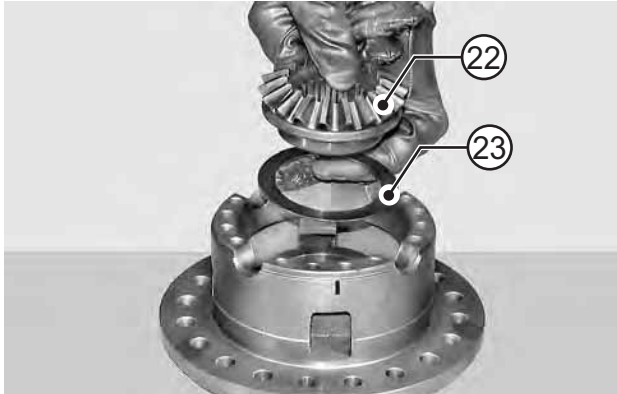

FIGURE 20: ASSEMBLY
Install the shoulder ring (23) and planetary gear (22) into the half-box (7).

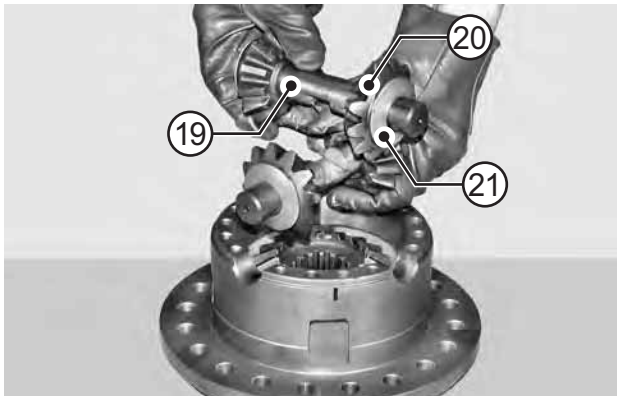

FIGURE 21: Install the planetary gears (20) and spherical shoulder washers (21) onto the shafts (19). Install the assemblies in the half-box (7).

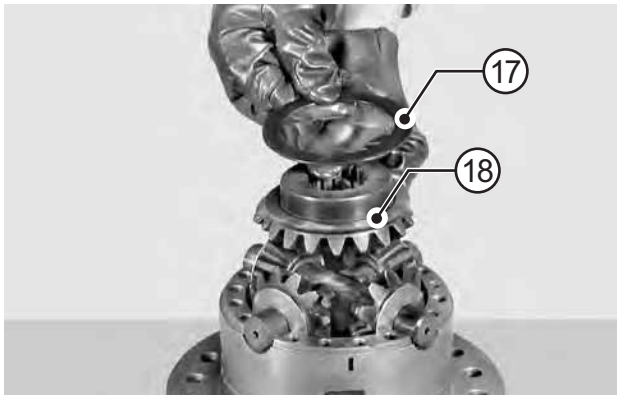

FIGURE 22: Install the planetary gear (18) and shoulder ring (17).

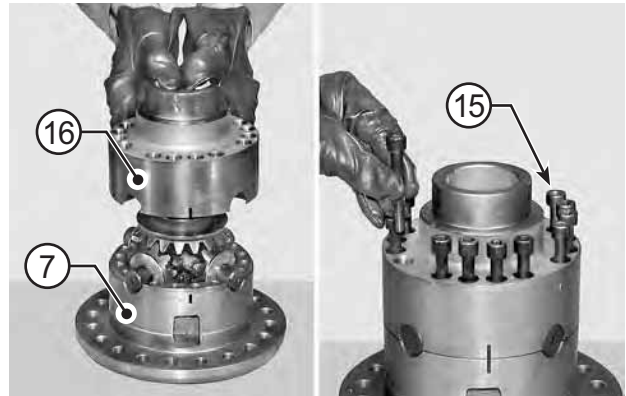

FIGURE 23: Mount the locking half-box (16) onto the half-box (7) and lock it with screws (15) coated with Loctite 270. Tighten temporarily by hand.

⚠ CAUTION

- 1 - The match marks on the two half-boxes must correspond.
- 2 - Use only new screws.

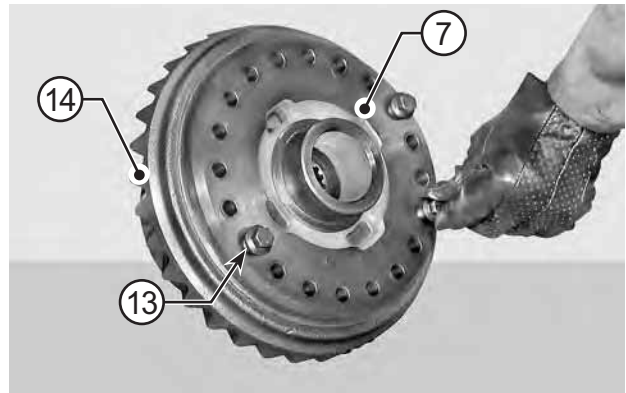

FIGURE 24: Mount the ring gear (14) and fasten it to the differential box (7) with screws (13) tightened temporarily by hand.

⚠ CAUTION

Use only new screws.

INSTALL AND ADJUST

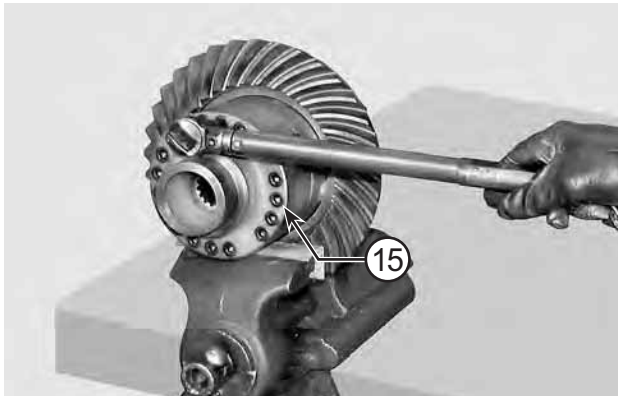

FIGURE 25: Fit the complete differential unit in a vice and tighten the screws (15) holding the two half boxes together to a torque of 140 - 154 N·m.

⚠ CAUTION

Tighten screws using the criss-cross method.

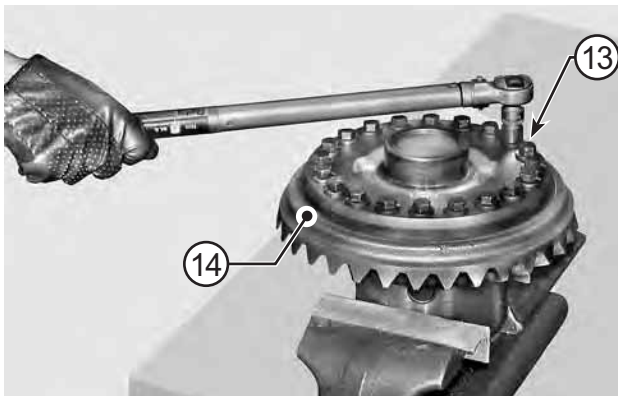

FIGURE 26: Lock the ring gear (14) by tightening the screws (13) to a torque of 115 - 142 N·m.

⚠ CAUTION

Tighten screws using the criss-cross method.

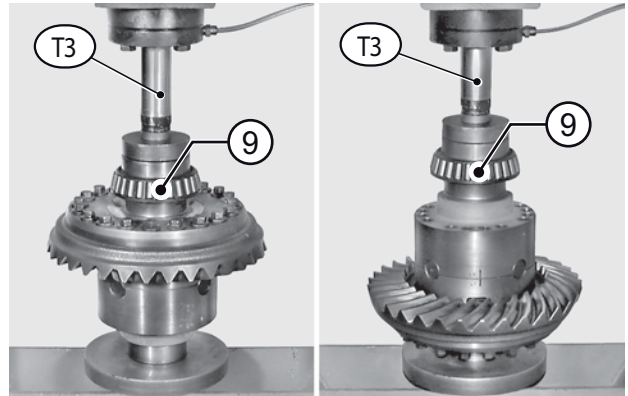

FIGURE 27: Position the differential unit under a press and fit it with bearings (9) using tool T3 (See drawing T3 p. 84).

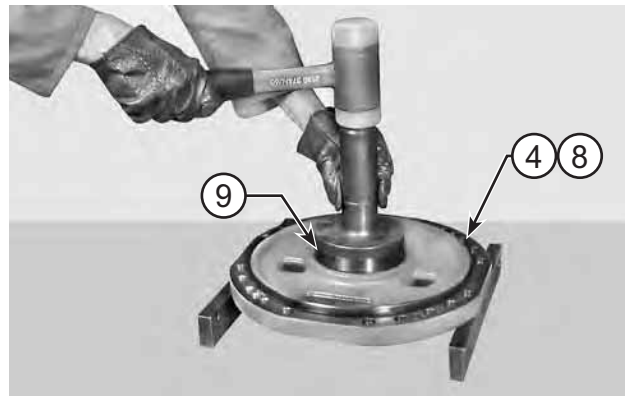

FIGURE 28: INSTALLATION
If bearings (9) are replaced, introduce the thrust blocks into intermediate covers (4) and (8).

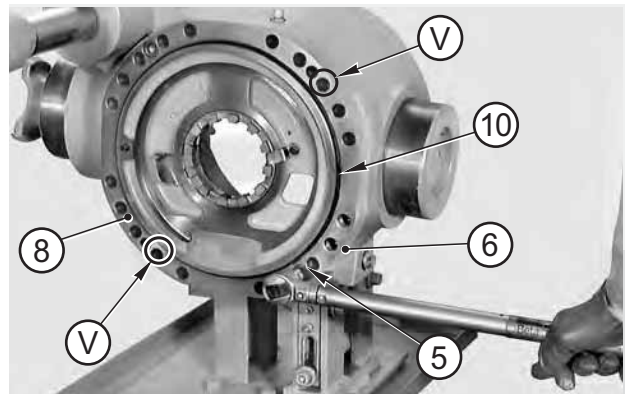

FIGURE 29: Fit the non-ring gear side of main body (6) complete of pinion with intermediate cover (8). Lock cover with screws (5) coated with Loctite 242 and with two service screws "V" (M16X50) tightened to a torque of 130 - 143 N·m.

ⓘ NOTE:

Check the condition of the o-ring (10).

INSTALL AND ADJUST

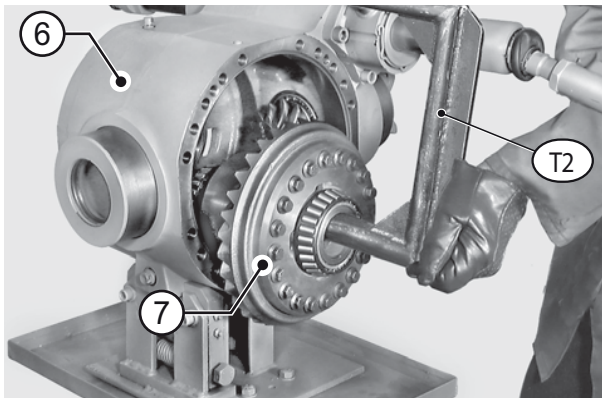

FIGURE 30: Using tool T2 (See drawing T2 p. 84), position the differential unit (7) into the main body (6).

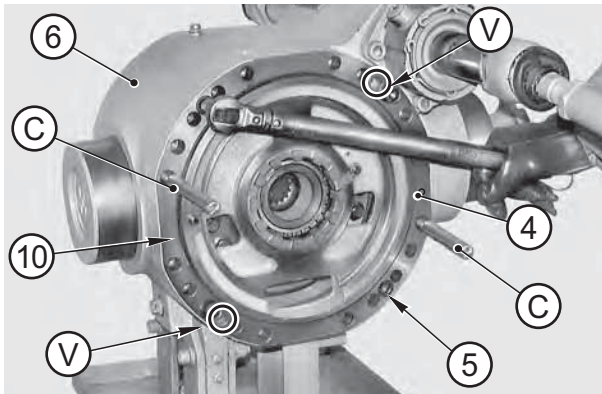

FIGURE 31: Tighten the two safety studs "C" into the main body (6) and install the intermediate cover (4). Lock into position with screws (5) treated with Loctite 242 and two service screws "V" (M16X50) to a torque of 130 - 143 N·m.

NOTE:

Check the condition of o-ring (10).

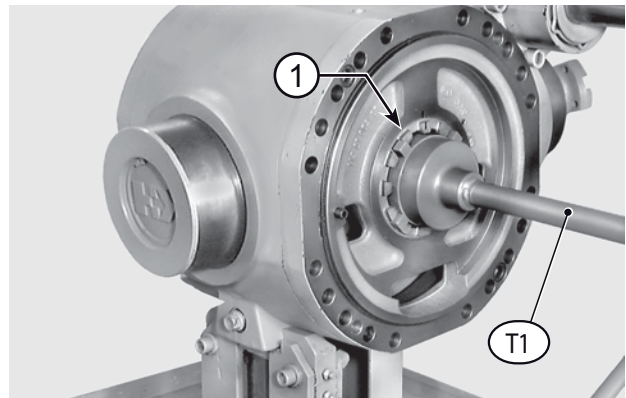

FIGURE 32: Only if the differential clearance and preload adjustment ring nuts have been removed, tighten the ring nuts (1) by 3 turns approximately. Coat with Loctite 222 and tighten in the relative intermediate covers.

Tighten the ring nut (1) on ring gear side until clearances between pinion and ring gear are zeroed. Then, loosen by about 1/4 - 1/2 turn.

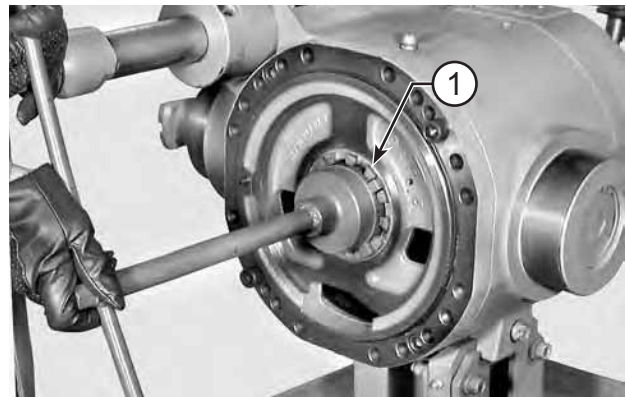

FIGURE 33: Only if ring nuts have been removed, preload bearings with ring nut (1) on non-ring gear side in order to increase the torque of the pinion.

CAUTION

In the case of used bearings, check thrust torque; in the case of new bearings, check continuous torque.

INSTALL AND ADJUST



FIGURE 34: Apply torque meter TM to pinion nut and check that torque will increase by 20 - 40 Ncm as a result of differential bearing preload.

Example: pinion torque: 120 - 130 Ncm
Pinion + differential torque: 140 - 170 Ncm.

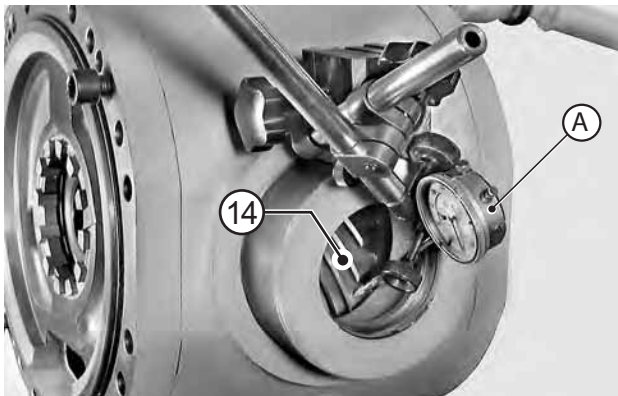

FIGURE 35: Introduce a dial indicator "A" with long tracer through the hole provided for the cap (12). Position the tracer on the side of a tooth of the ring gear, approximately 5 mm from the outer rim; preload by about 1 mm and zero the dial indicator.

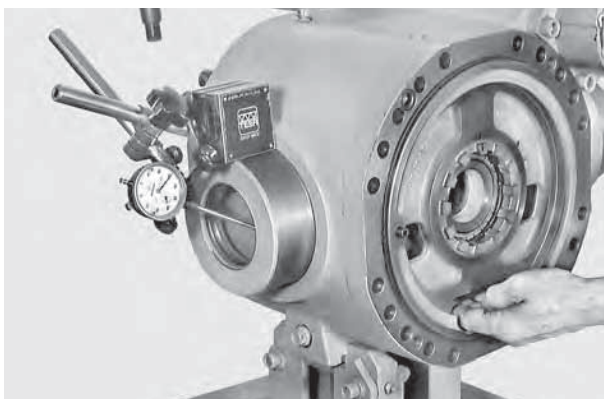

FIGURE 36: As you hold the pinion in position, move the ring gear (14) manually in both directions to check clearance between pinion and ring gear. Standard clearance. See table

RATIO - RAPPORT VERHÄLTNIS - RAPORTE - RAPPORT	CLEARANCE - GIOCO - SPIEL JUEGO - JEU	
	MIN.	MAX.
9 ÷ 29	0,25	0,33
9 ÷ 33	0,25	0,33
11 ÷ 34	0,25	0,33

FIGURE 37: CAUTION! Difference between minimum and maximum clearance for whole circumference must not exceed 0.09 mm.

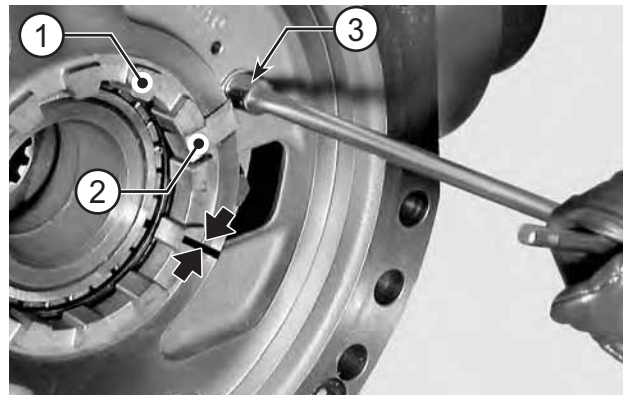

FIGURE 38: If torque and/or pinion-ring gear clearance is not within tolerance values and the ring nuts have not been removed, mark the position of the ring nuts (1) and remove the safety plates (2).

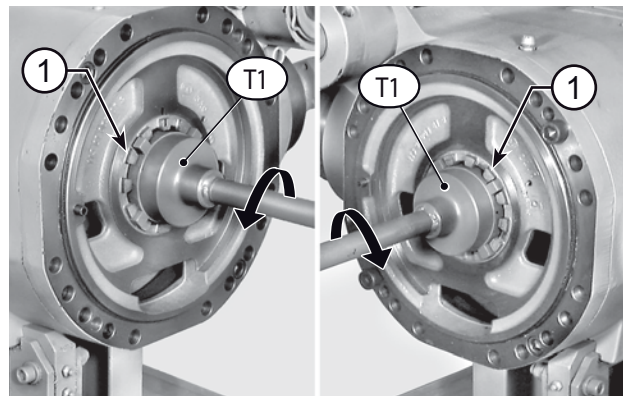

FIGURE 39: Adjusting clearance between pinion and ring gear.

To INCREASE: loosen the ring nut on ring gear side and tighten the ring nut on non-ring gear side by the same measure.

To DECREASE: perform the same operations inversely. To rotate ring nuts, use special wrench T1 (See drawing T1 p. 83).

INSTALL AND ADJUST

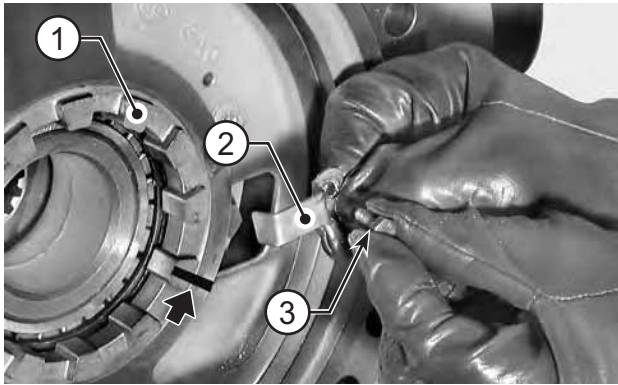

FIGURE 40: Install the stops (2) for the ring nuts (1). Engage stops in the slot next to the holes provided for the check screws. Coat screws (3) with Loctite 242 and tighten to a torque of 7 - 10 N·m.

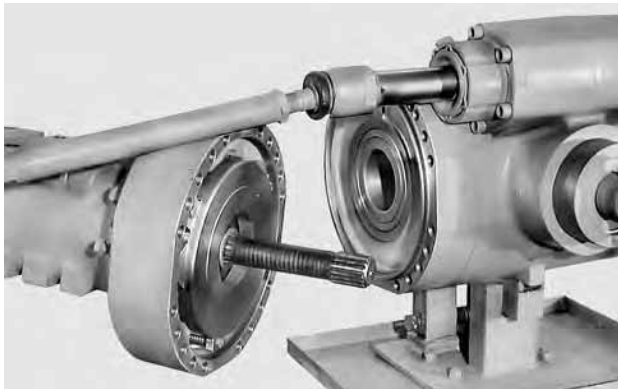
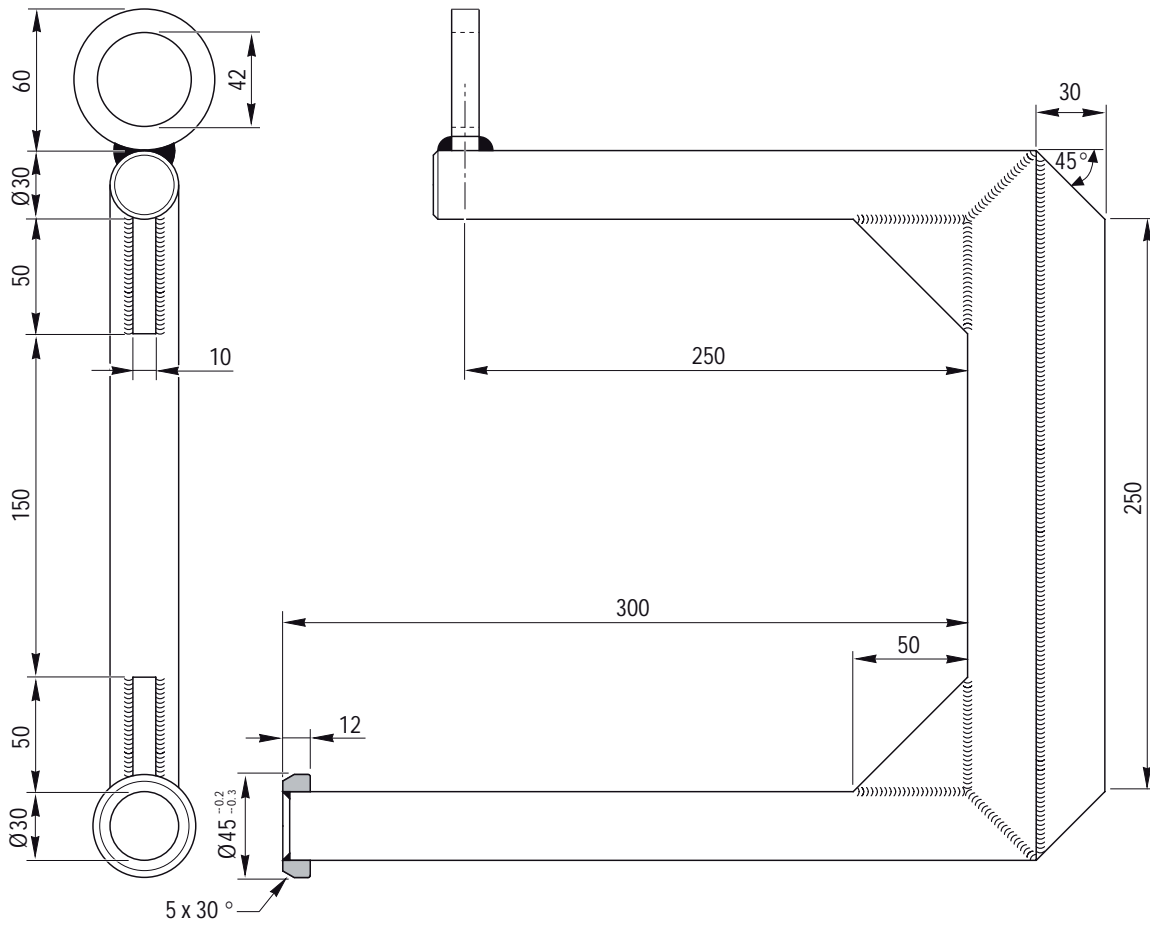

FIGURE 41: Install negative brake cylinders and arms. For details, see CHECKING WEAR AND REPLACING THE BRAKING DISCS p. 17.

SPECIAL TOOLS

T2

P/N: 2370



T3

P/N: 2371

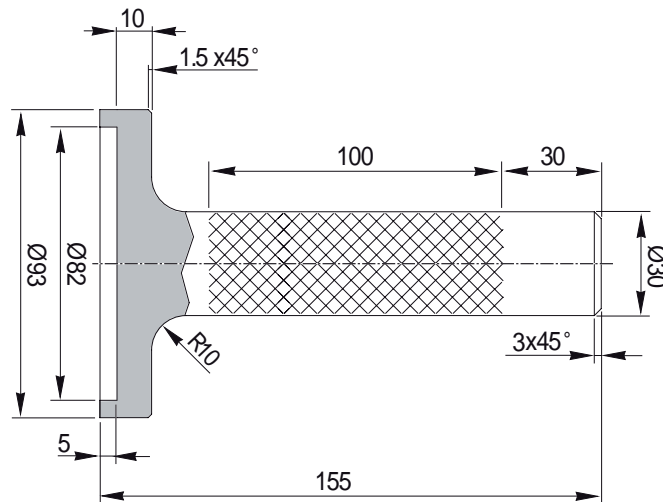

BEVEL PINION

EXPLODED VIEW

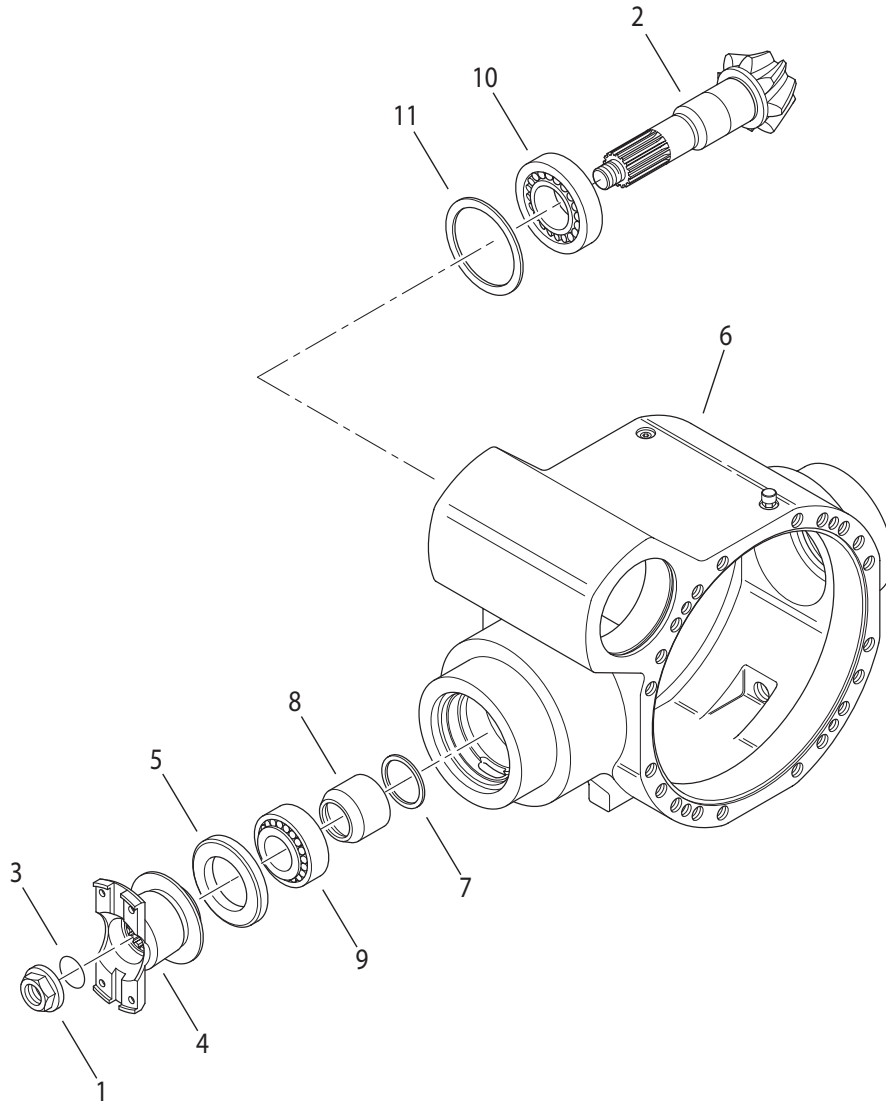

DISASSEMBLY

DISASSEMBLY



FIGURE 1: Remove the arms, negative brake cylinders and differential unit.
For details, see CHECKING WEAR AND REPLACING THE BRAKING DISCS p. 17 and DIFFERENTIAL UNIT p. 73.

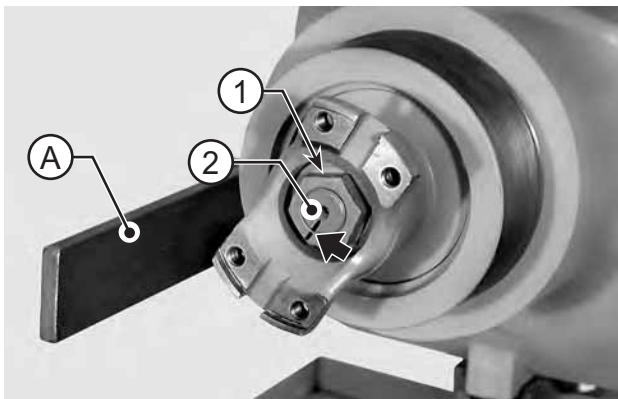

FIGURE 2: Make match marks across the joint seam between nut (1) and pinion (2) and apply a reaction bar "A" to the main body.

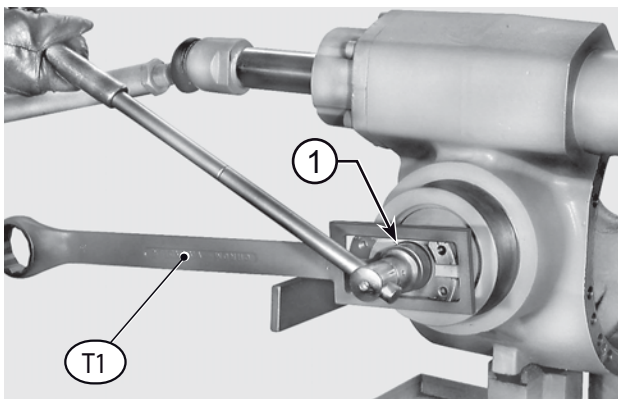

FIGURE 3: Apply wrench T1 (See drawing T1 p. 94) to hold the pinion tight and, using a socket wrench, loosen nut (1).

⚠ CAUTION

If disassembly proves hard, heat the nut (1) with a heat gun to a temperature of about 176 °F [80 °C].



FIGURE 4: Remove nut (1) and o-ring (3).

📌 NOTE:

If the nut is heated to assist removal, then the o-ring must be replaced.

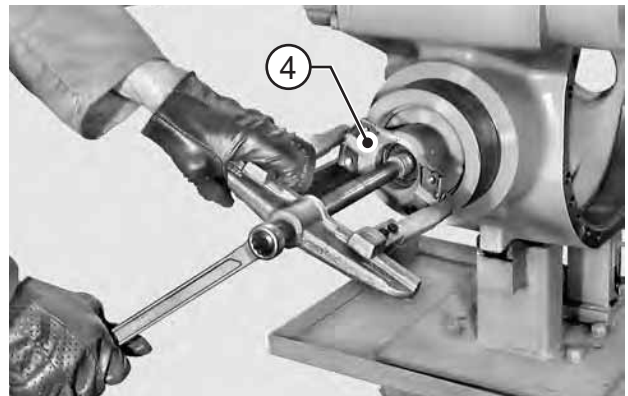

FIGURE 5: Using a puller, pull out and remove the flange (4).

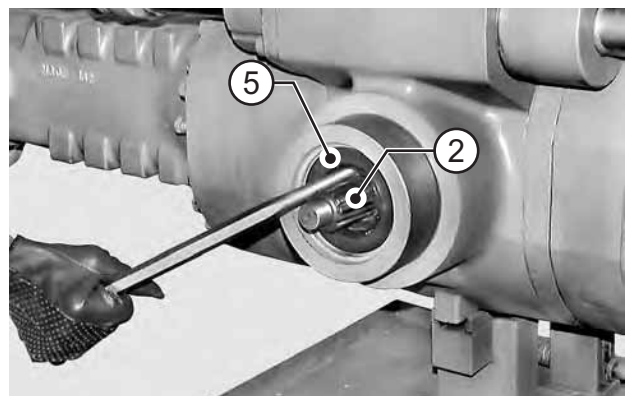

FIGURE 6: If only the seal ring (5) of pinion (2) is to be replaced, pull ring out using a screwdriver or a lever.

NOTE:

- 1 - Do not damage ring seat and pinion.
- 2 - Replace the seal ring and install the new one using tool T4 (See drawing T4 p. 97) once AREXSONS rubber cement has been applied to the outer surface; smear with Loctite 270 the pinion thread and tighten nut (1) up to the marks.

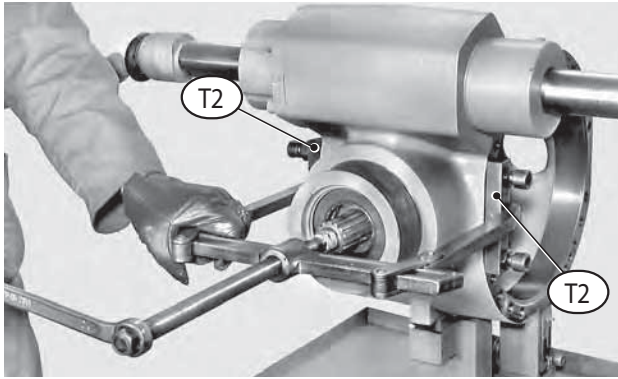

FIGURE 7: Apply small blocks T2 (See drawing T2 p. 95) to the main body (6) and, using a puller, remove the entire pinion (2).

NOTE:

Outer bearing and thrust blocks remain in the main body (6).

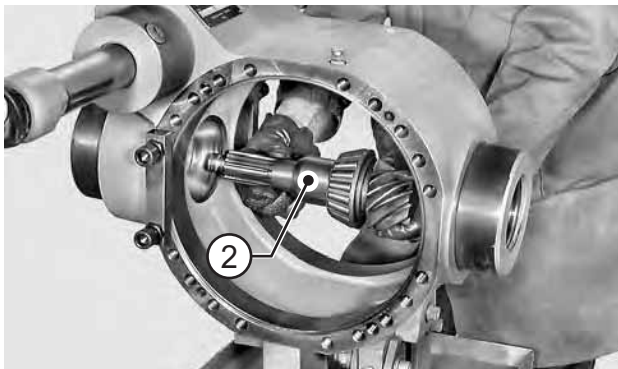

FIGURE 8: Remove pinion (2), calibrated spacer (7), and spacer (8).

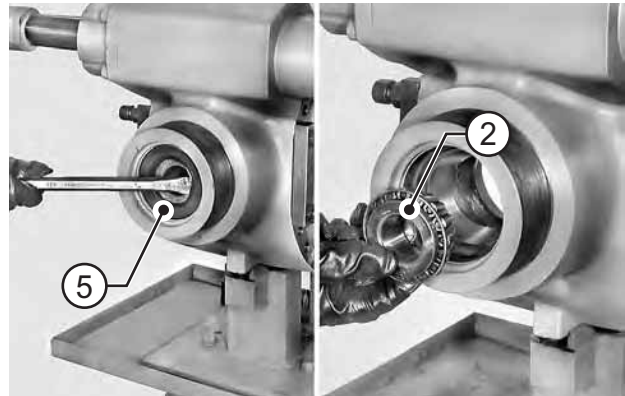

FIGURE 9: Remove the seal ring (5) of pinion (2) and outer bearing (9).

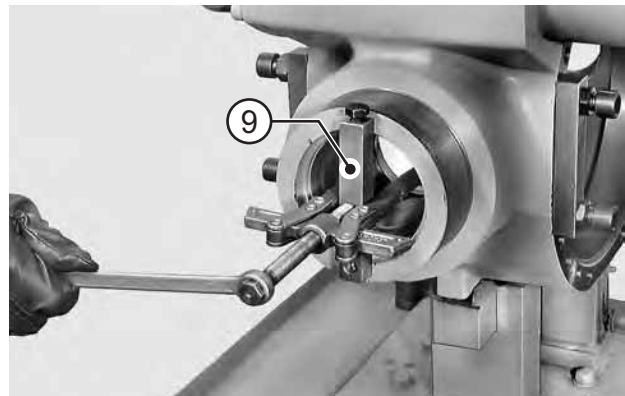

FIGURE 10: Using a puller for inner parts, remove the thrust block of outer bearing (9).

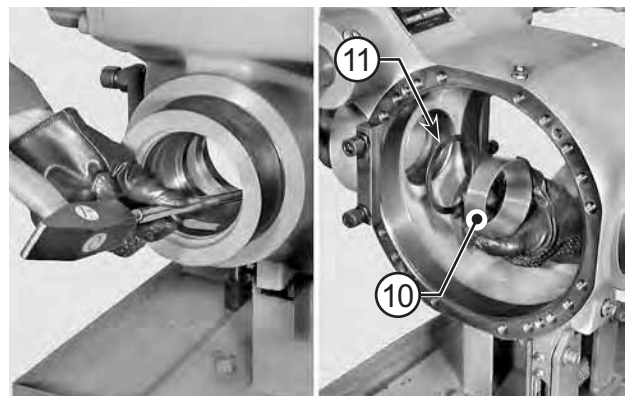

FIGURE 11: Using a punch of soft material, remove the thrust block of inner bearing (10) and shims (11).

DISASSEMBLY

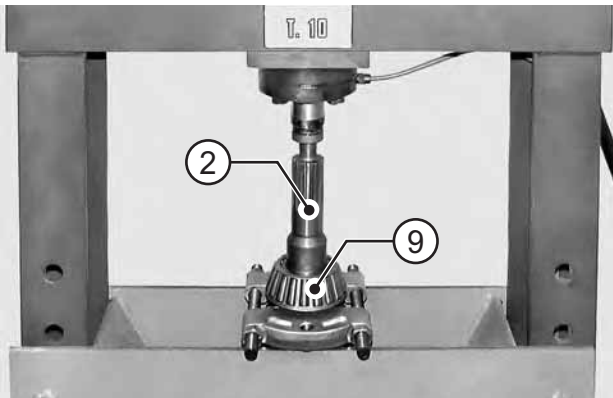

FIGURE 12: Using a separator and a press, remove the inner bearing (9) from the pinion (2).

INSTALL AND ADJUST

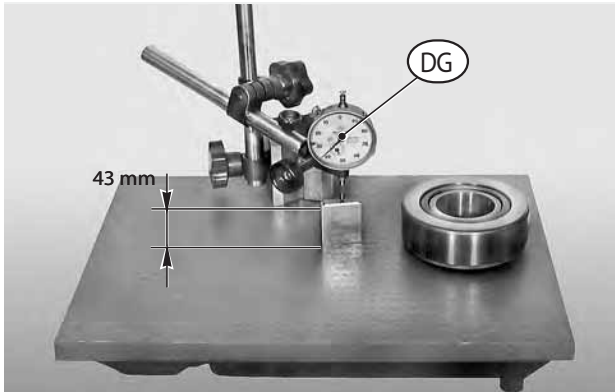

FIGURE 13: CALCULATING PINION CENTER DISTANCE
Using a faceplate, reset a dial indicator "DG" on a calibrated block (whose known thickness is 43 mm). Preload the comparator by about 3 mm.

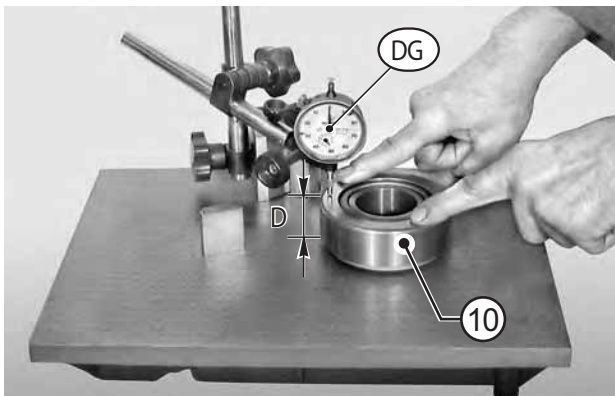

FIGURE 14: Bring inner bearing (10), complete with thrust block, under the dial indicator "DG". Calculate total thickness "D" of bearing by checking deviation compared with the dimension of block.
EXAMPLE: $43 - 0.62 = 42.38 = "D"$.

CAUTION

Press the thrust block centrally and carry out several measurements by rotating the thrust block.

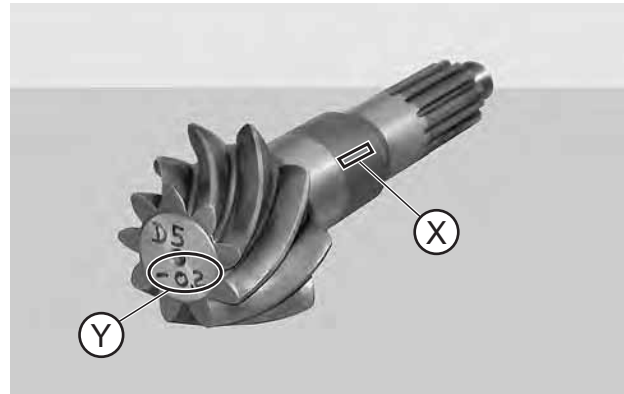

FIGURE 15: Check nominal dimension "X" as marked on the pinion. Add up to or subtract from "X" the variation indicated as "Y" to obtain the actual center distance "I".
EXAMPLE: $I = 153 - 0.2 = 152.8$

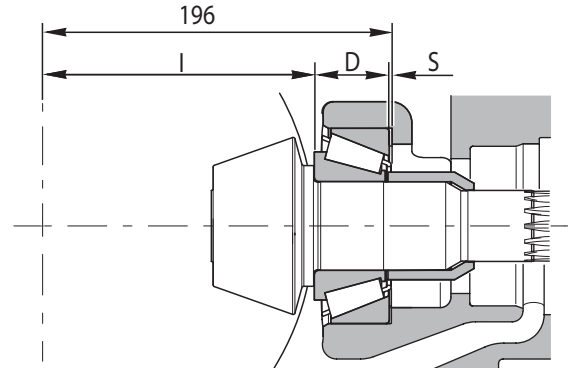

FIGURE 16: Calculate shims "S" for insertion under the thrust block of the inner bearing using the following formula:
 $S = 196 - (I + D)$ where: 196 = fixed dimension
I = actual pinion Center distance
D = Total bearing thickness;
EXAMPLE: $S = 196 - (152.8 + 42.38) = 0.82$ mm.



FIGURE 17: Subtract 0.05 - 0.07 mm from the resulting S value, until the value is rounded off to the lower 5/100.
EXAMPLE: $S = 0.82 = 0.75$ mm.
Make up the pack of shims "S".

INSTALL AND ADJUST

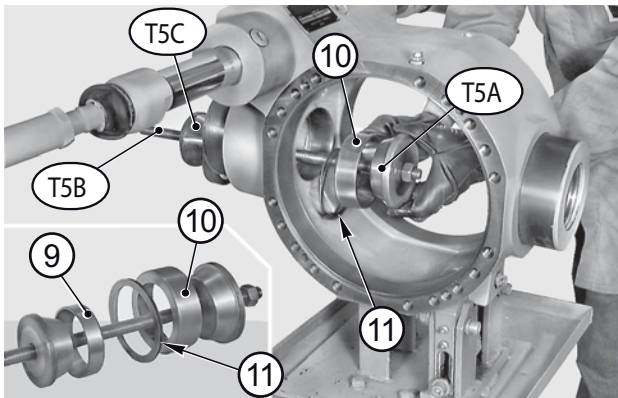

FIGURE 18: Assemble driver T5A (See drawing T5 p. 98), thrust block of inner bearing (10) and pack of shims (11) onto tension bar T5B (See drawing T5 p. 98) Introduce the tension bar into the main body and mount the thrust block of outer bearing (9) and driver T5C (See drawing T5 p. 98).

NOTE:

Grease shims to hold in position.



FIGURE 19: Connect the tension bar to the press and push the thrust blocks of bearings (9) and (10) into their seats. Disconnect from the press and remove tension bar and drivers.

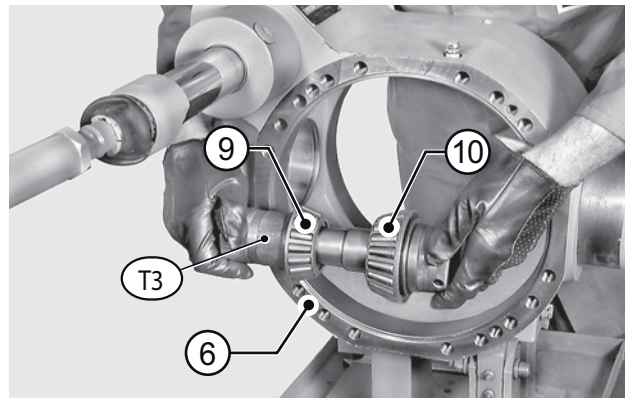

FIGURE 20: CALCULATING PINION BEARINGS ROLLING TORQUE
Introduce tool T3 (See drawing T3 p. 96) complete with bearings (9) and (10) into the main body (6); tighten by hand until a rolling torque is definitely obtained.

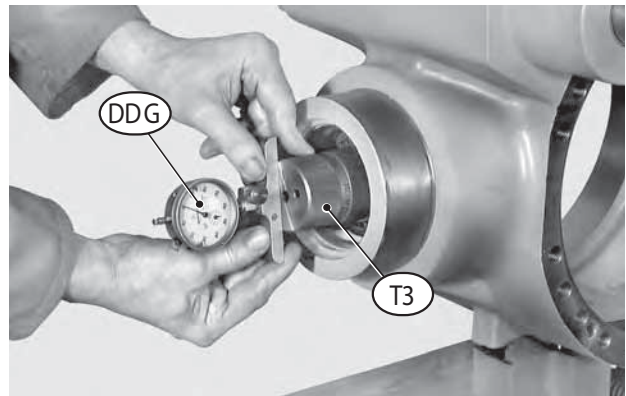

FIGURE 21: Introduce the tracer of a depth gauge "DDG" into either side hole of tool T3 (See drawing T3 p. 96). Reset the comparator with a preload of about 3 mm.

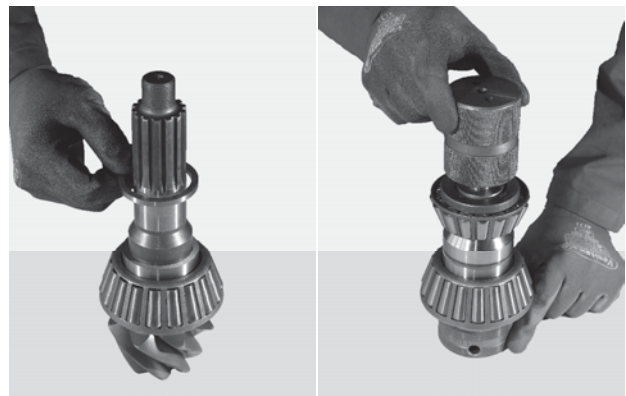

FIGURE 22: Remove the comparator and remove tool and bearing kits from the main body. Reinstall every part, also introducing a spacer (8) between bearings (9) and (10). Tighten the entire pack by hand.

INSTALL AND ADJUST

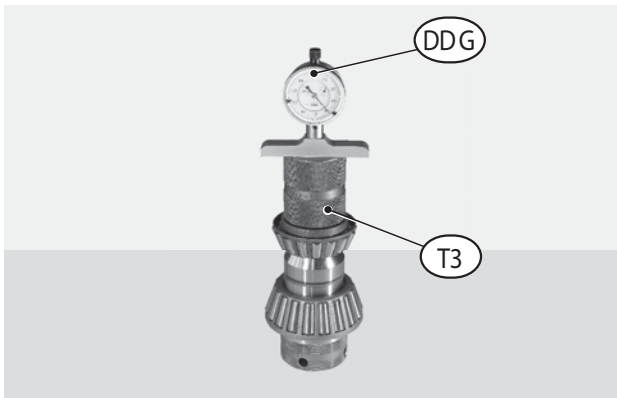

FIGURE 23: Introduce depth gauge "DDG" in tool T3 (See drawing T3 p. 96) and measure deviation "H" from the previous reset.
EXAMPLE: "H" = 1.19 mm.

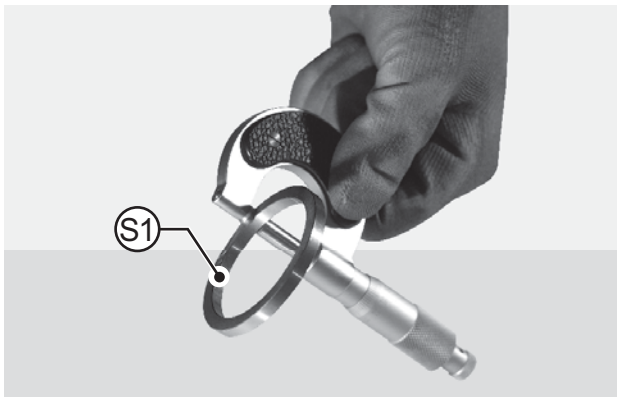

FIGURE 24: Deviation "H" must be added to a set value of 0.12 - 0.15 mm to obtain the calibrated spacer "S1" (7) for insertion between inner bearing (10) and spacer (8). Dimension "S1" must be rounded off to the higher 5/100.
EXAMPLE: $S1 = H + X = 1.19 + (0.12 - 0.13) = 1.33 = 1.35$ mm.

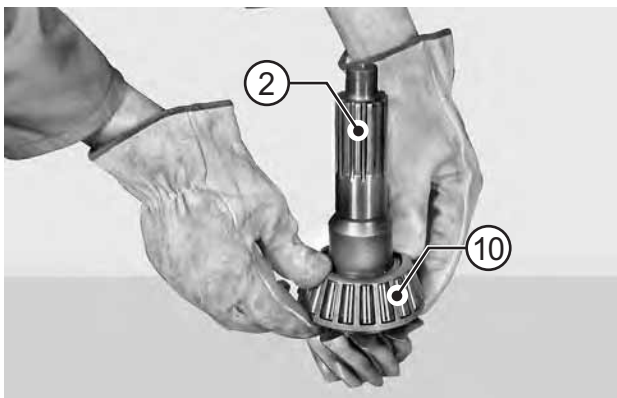

FIGURE 25: Heat the inner bearing (10) to about 212 °F [100 °C] and fit it onto the pinion (2).

NOTE:

Once the bearing has cooled down, lightly lubricate bearing (10) with SAE85W90 oil.

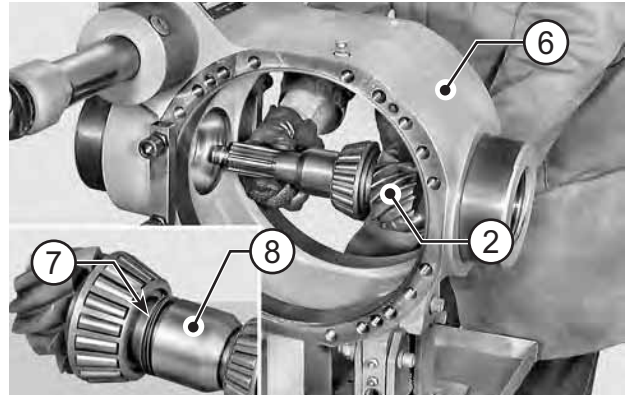

FIGURE 26: Fit the pinion (2), calibrated spacer (7) and spacer (8) in the main body (6).

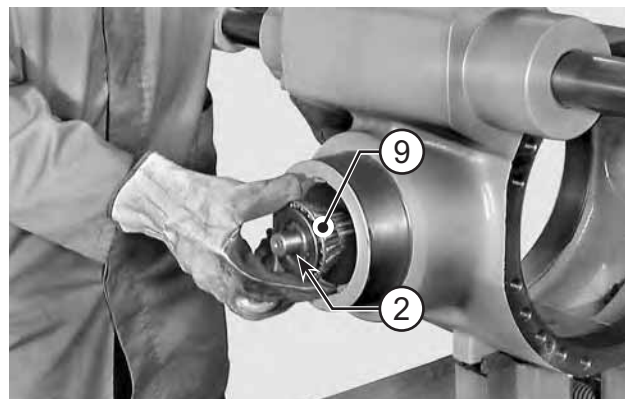

FIGURE 27: Heat the external bearing (9) to a temperature of about 212 °F [100 °C] and fit it on to the pinion (2) to complete the pack as shown in the figure above.

NOTE:

Lightly lubricate bearing (10) with SAE85W90 oil.

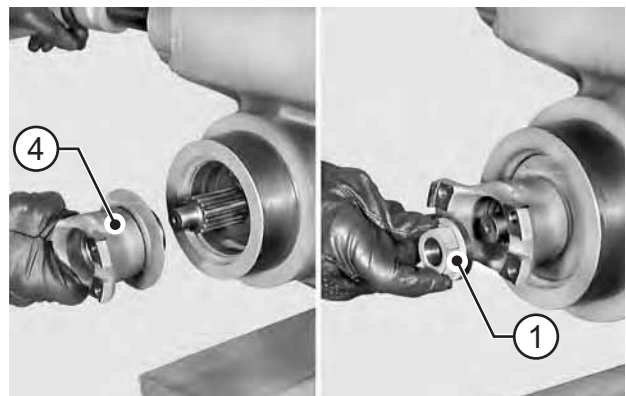

FIGURE 28: Install flange (4) and nut (1).

INSTALL AND ADJUST

⚠ CAUTION

Do not mount the seal ring (5) and o-ring (3) at this stage.

📌 NOTE:

If necessary, use a plastic hammer to align the flange.

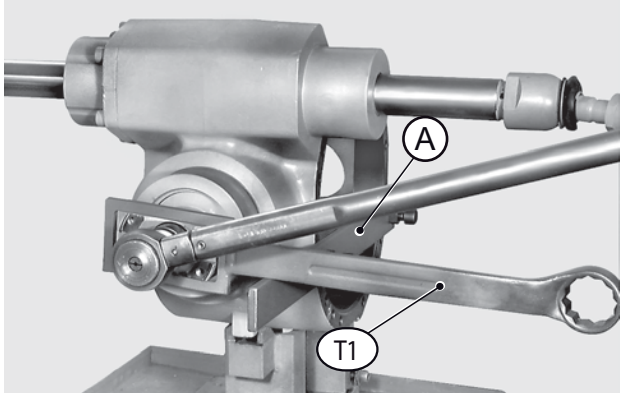

FIGURE 29: From the main body (6), remove the small reaction blocks T2 (See drawing T2 p. 95) for pinion extraction and install reaction bar "A".

Engage tool T1 (See drawing T1 p. 94) on the flange and tighten nut (1) to the minimum permitted torque.

Permitted torque: 600 - 800 N·m.

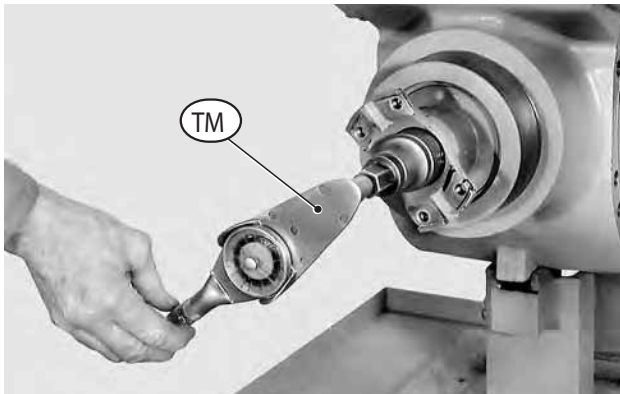

FIGURE 30: Apply a torque meter "TM" onto pinion nut (1) and check pinion torque. Torque: 120 - 150 Ncm

⚠ CAUTION

If torque exceeds maximum value, increase calibrated spacer "S1" (7) between bearing (10) and spacer (8). If torque does not reach the set value, increase the tightening torque of nut (1). Do this in several stages until the maximum permitted value of 800 N·m is reached.

If torque does not reach minimum value, reduce calibrated spacer "S1" (7).

In order to be able to calculate increase or reduction in calibrated spacer "S1" it should be taken into account that for every 0.01 mm. variation in calibrated spacer (7), pinion (2) torque varies by 60 Ncm.

Before completing the installation of the pinion and relative seals, install the differential unit.

For details, see DIFFERENTIAL UNIT p. 73.

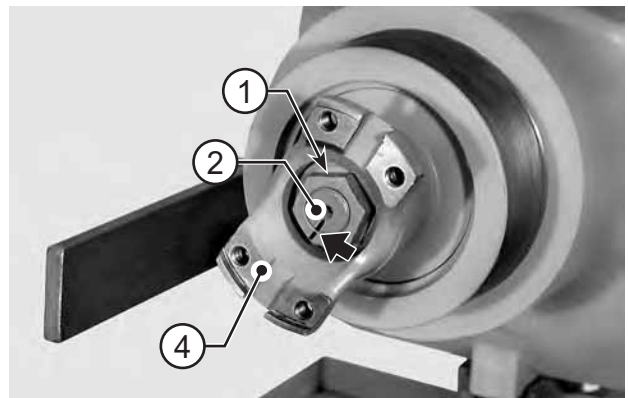

FIGURE 31: Make positional marks across nuts (1) and pinion tang (2); then, remove nut and flange (4).

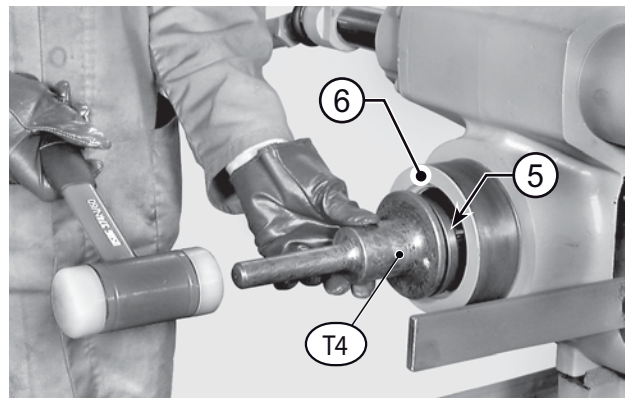

FIGURE 32: Apply Arexons rubber cement to the outer surface of the new seal ring (5) and fit ring in the main body (6) using driver T4 (See drawing T4 p. 97).

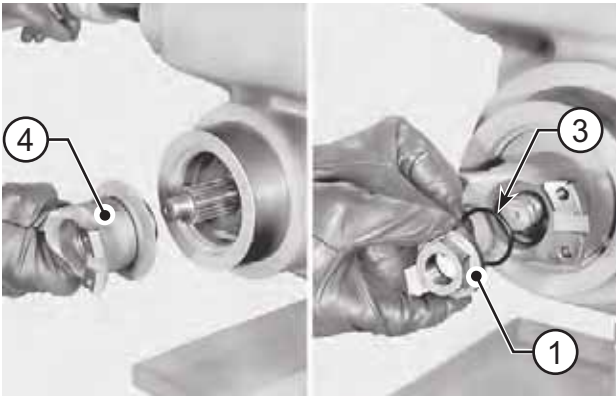

FIGURE 33: Oil seal ring lips and install flange (4). Mount o-ring (3) and apply Loctite 270 to pinion tang; tighten nut (1).

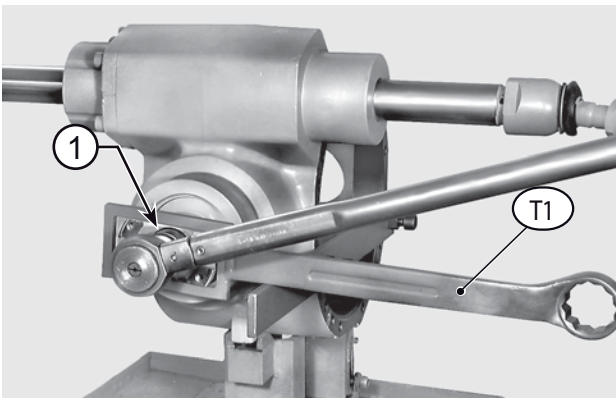

FIGURE 34: Tighten the nut until the match marks line up.

SPECIAL TOOLS

SPECIAL TOOLS

T1

P/N: 2372

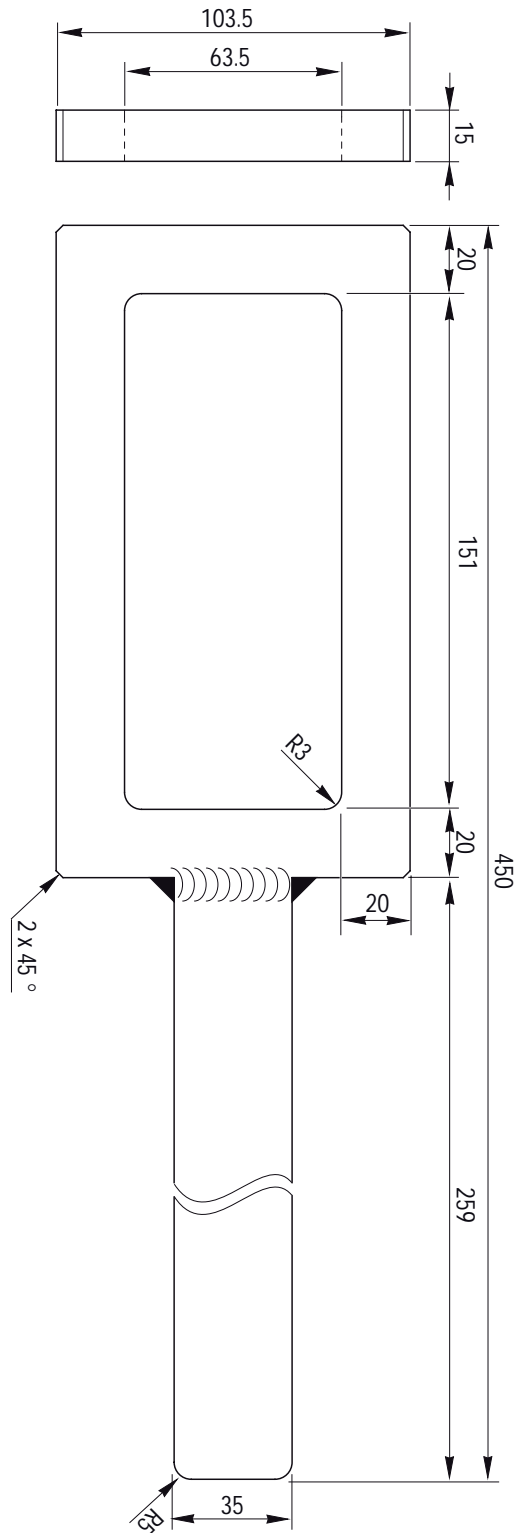

T2

P/N: 2373

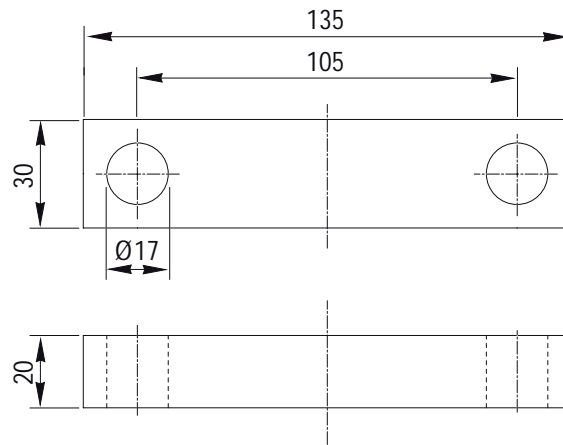

SPECIAL TOOLS

T3

P/N: 2374

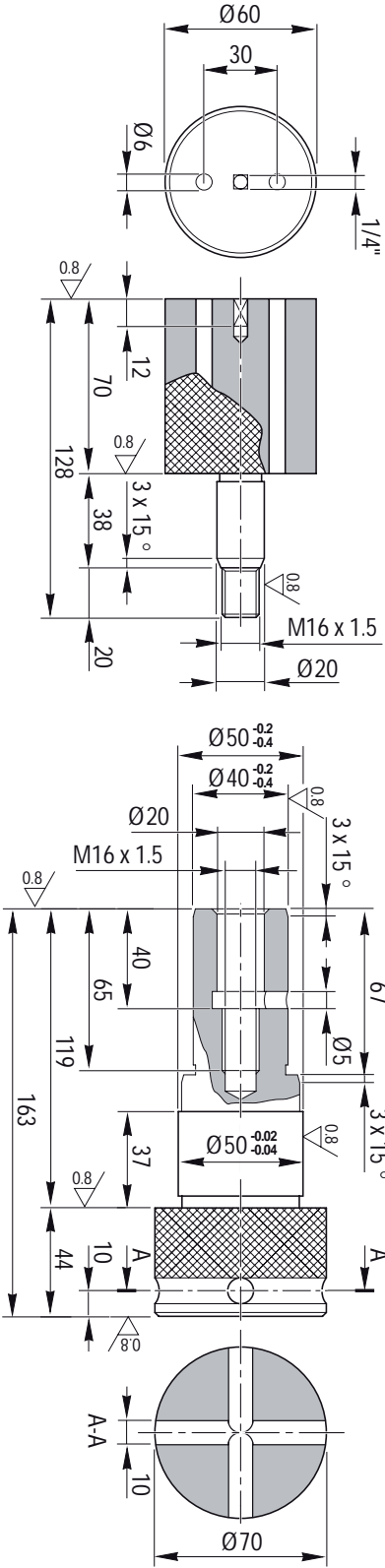

T4

P/N: 2375

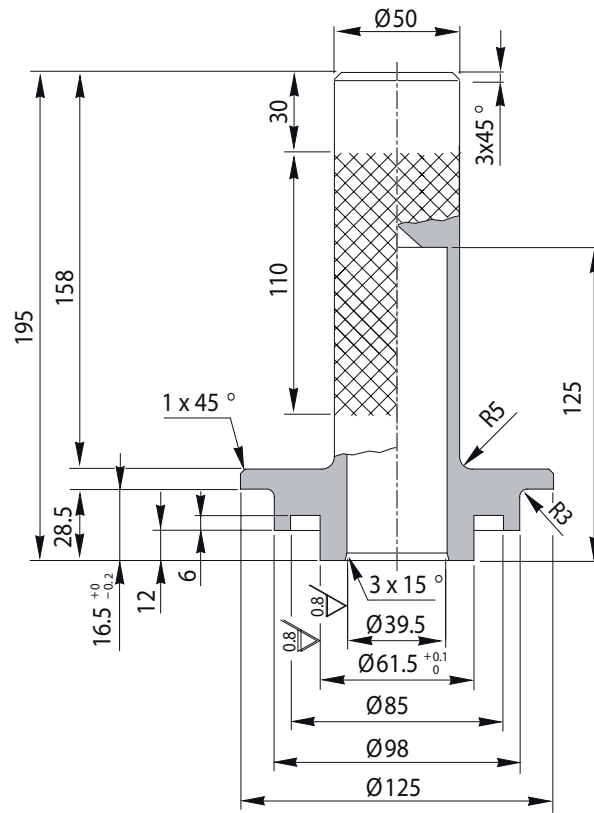

SPECIAL TOOLS

T5

P/N: 2377

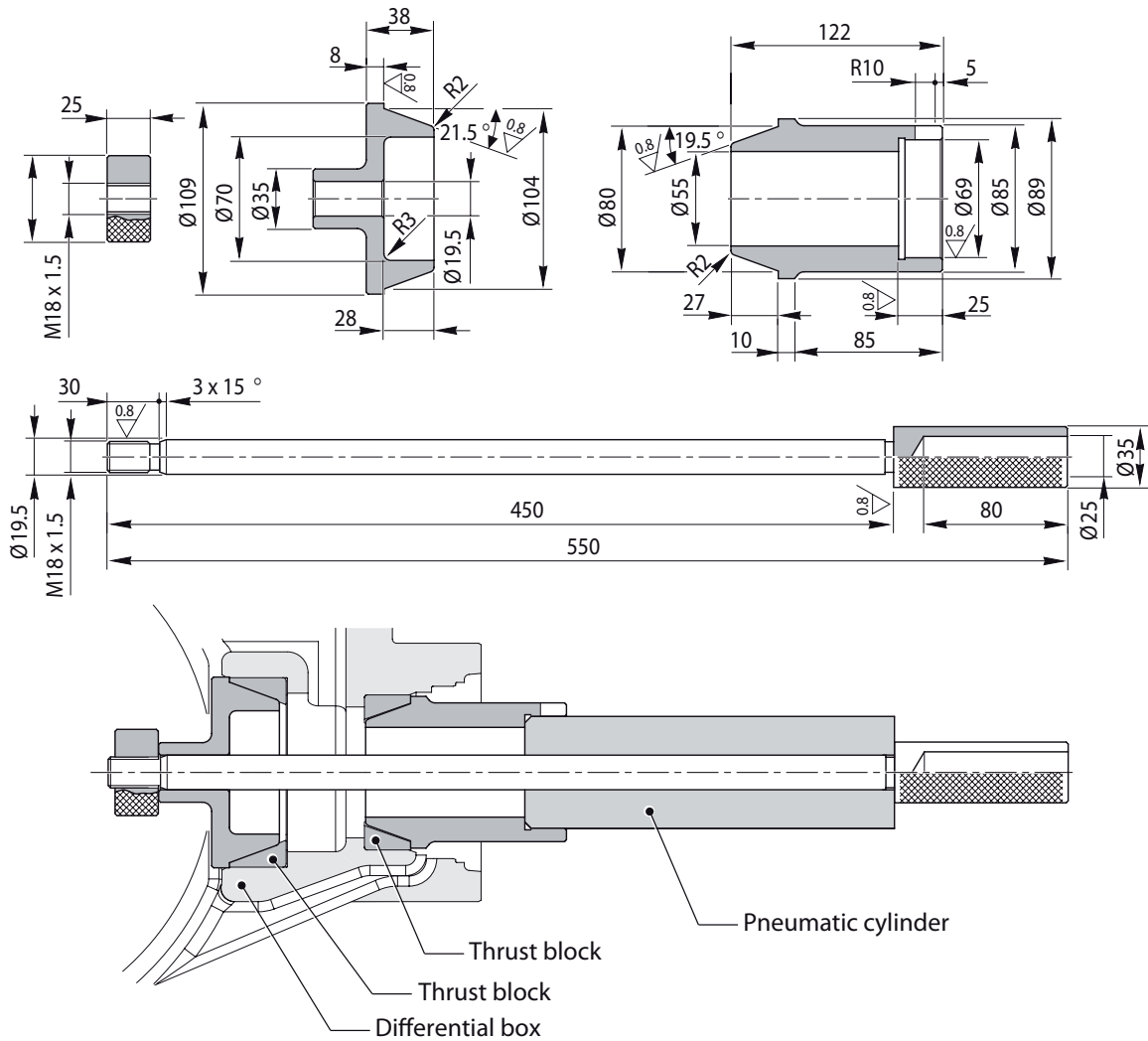

HYDRAULIC DIFFERENTIAL UNIT

EXPLODED VIEW

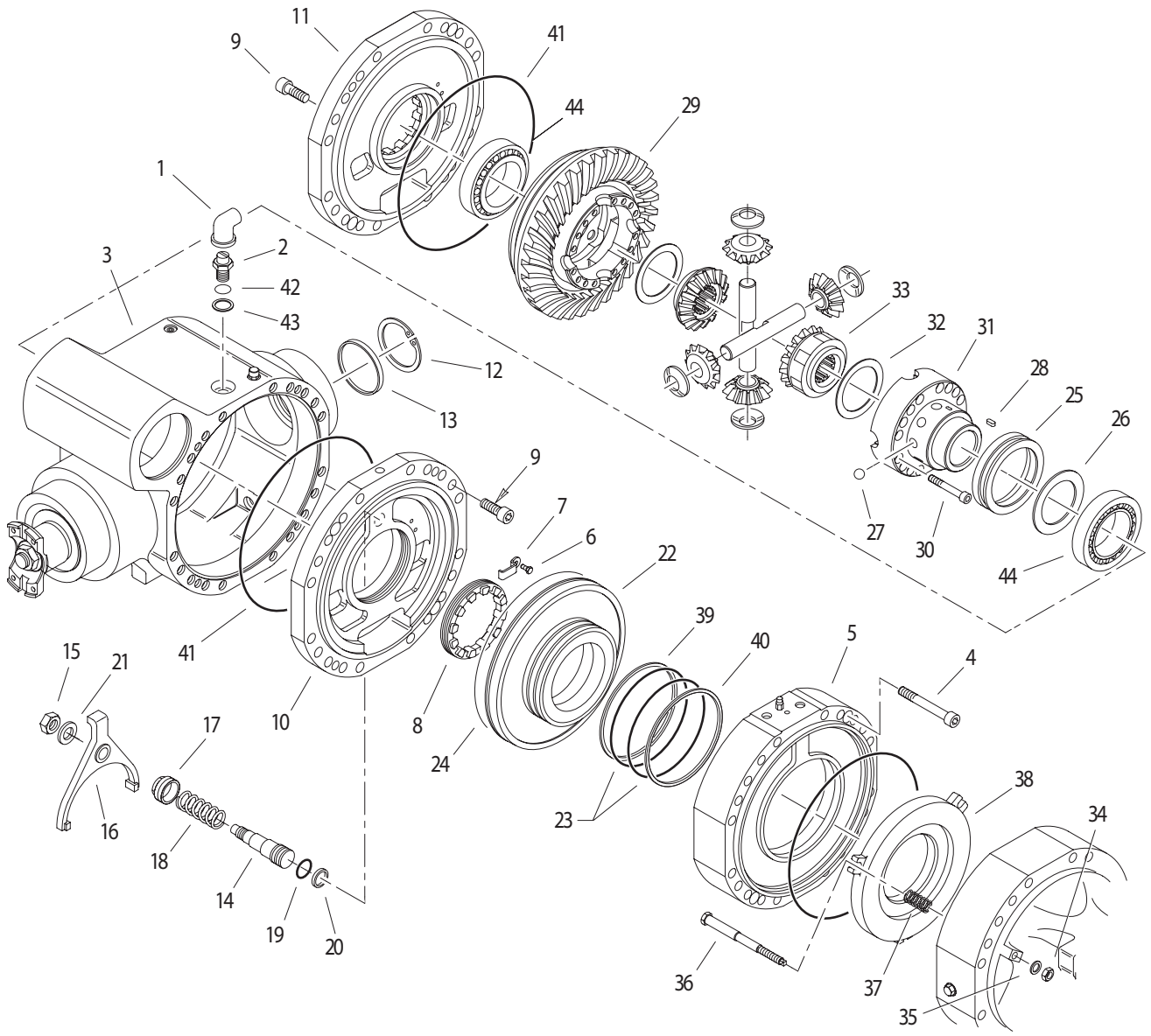

DISASSEMBLY

DISASSEMBLY

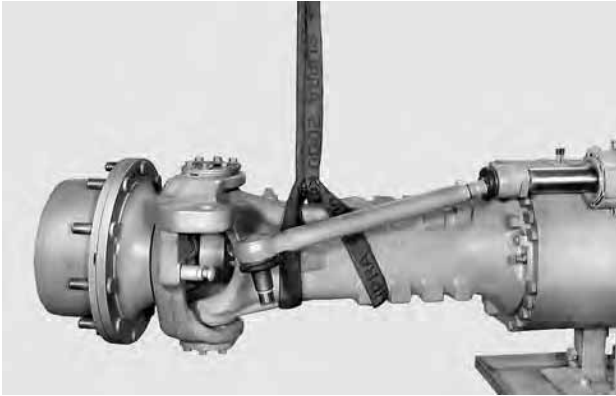

FIGURE 1: Remove the arms. For details, see CHECKING WEAR AND REPLACING THE BRAKING DISCS p. 17.

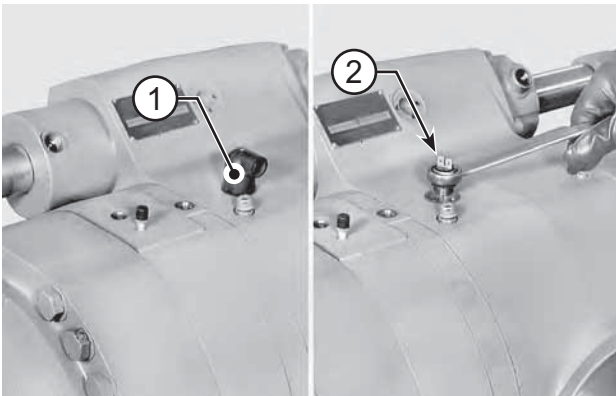

FIGURE 2: Remove both guard (1) and microswitch (2).

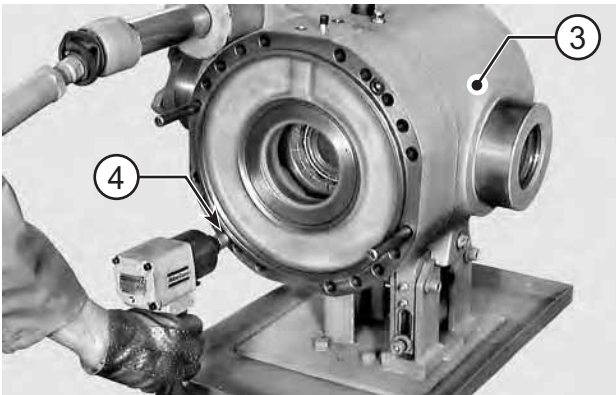

FIGURE 3: Tighten two safety studs "A" (M16) in two opposing holes in the main body (3). Loosen and remove the screws (4).

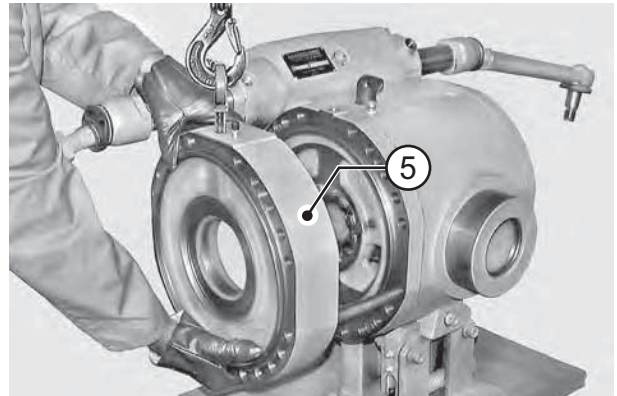

FIGURE 4: Connect to a hoist and remove the complete brake cylinder (5).

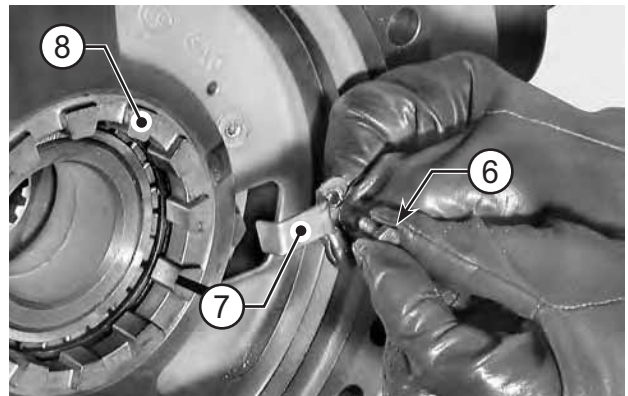

FIGURE 5: Remove screws (6) and safety plates (7) from adjustment ring nuts (8).

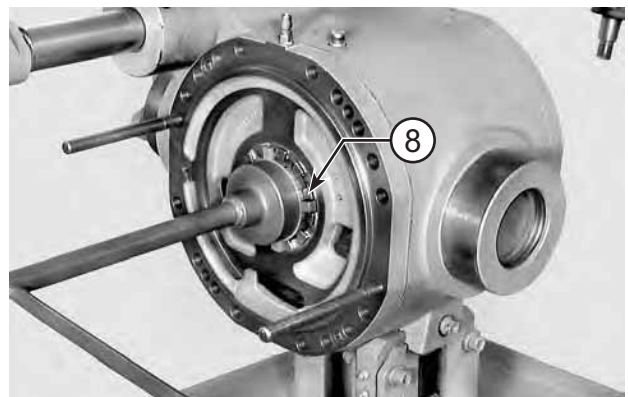

FIGURE 6: Only if locking piston seal is replaced: make positional marks across the adjustment ring nut on non-ring gear side. Loosen the ring nut (8) by about 6 mm (4 turns).

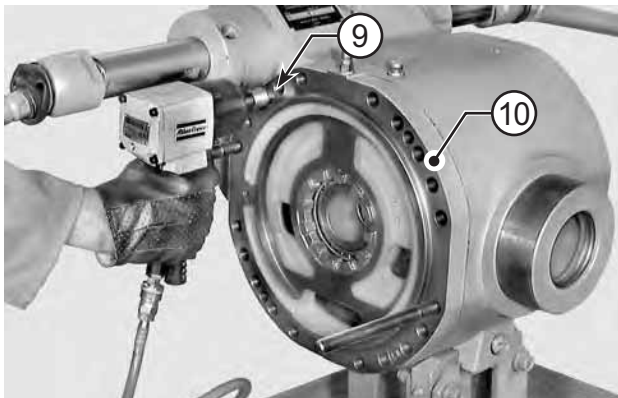

FIGURE 7: Loosen and remove check screws (9) from intermediate cover (10) and apply a compressed air connection "B" to the lock's pressure intake hole.
Thread: M14x1.5

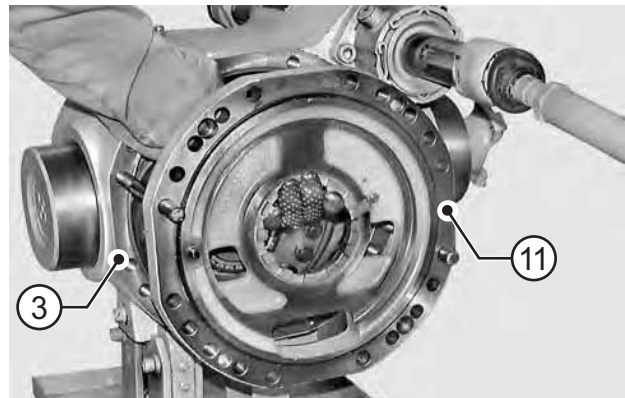

FIGURE 10: Support the differential unit and disconnect intermediate cover (11) from main body (3). Remove cover (11).



FIGURE 8: Introduce low-pressure compressed air through connection "B" and make sure that the lock control piston comes out at end of stroke.
Remove safety studs, rotate cover (10) to an angle of about 45°, and remove cover.

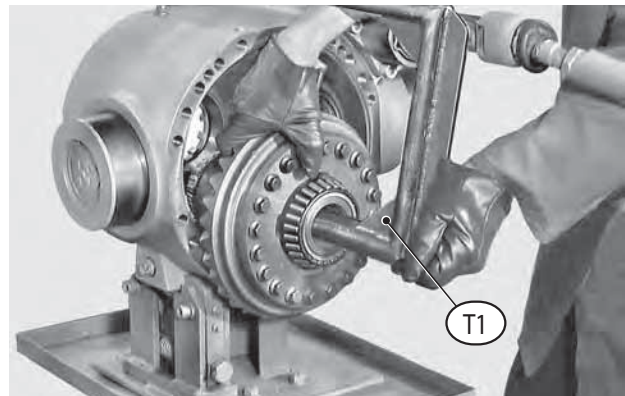

FIGURE 11: Remove the differential unit by using tool T1 (See drawing T1 p. 108) and position the unit on a workbench.

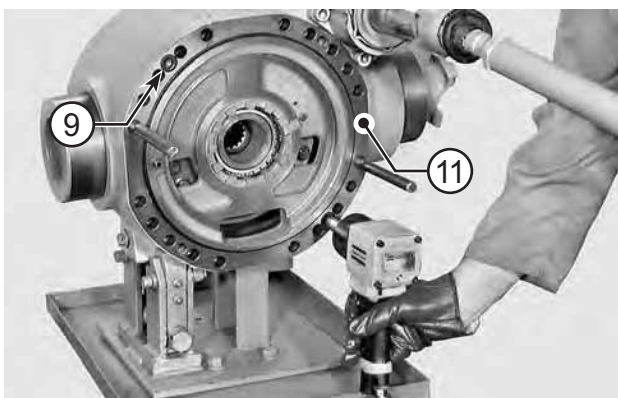

FIGURE 9: Tighten two safety studs "A" (M16) in the main body. Loosen and remove check screws (9) from intermediate cover (11) on ring gear side.

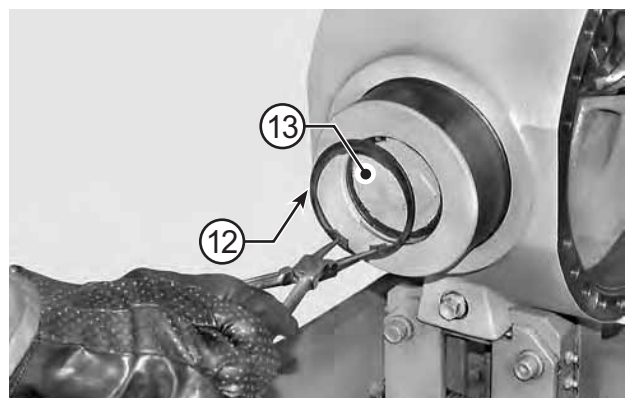

FIGURE 12: Remove the snap ring (12) and locking cap (13).

NOTE:

Replace the cap at each disassembly.

DISASSEMBLY

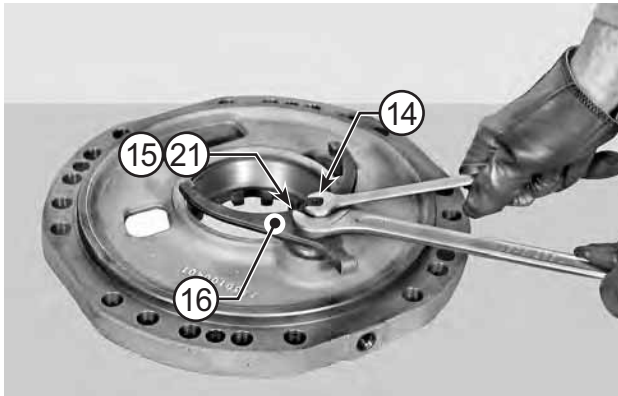

FIGURE 13: CONTROL DISASSEMBLY
While holding piston (14) in position, loosen selector fork (16) check nut (15).
Remove nut (15) and spring washer (21).

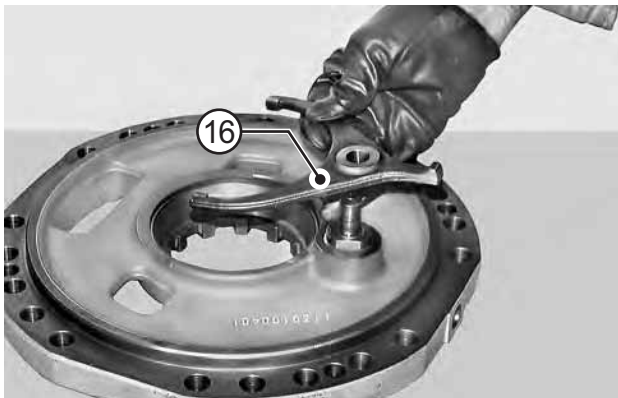

FIGURE 14: Remove selector fork (16).

NOTE:

Write direction of installation and thoroughly inspect pad for wear.

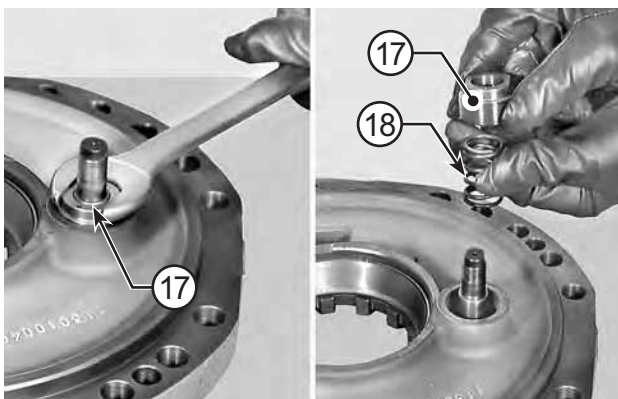

FIGURE 15: Loosen piston stop ring nut (17); remove ring nut and spring (18).

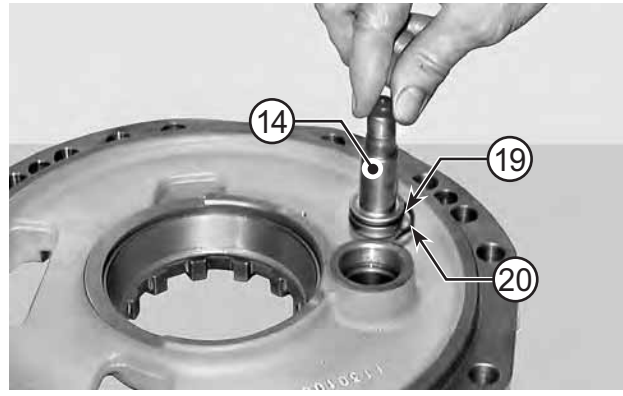

FIGURE 16: Remove piston (14) complete with o-ring (19) and guide pad (21).

NOTE:

Replace pad and o-ring at each disassembly.

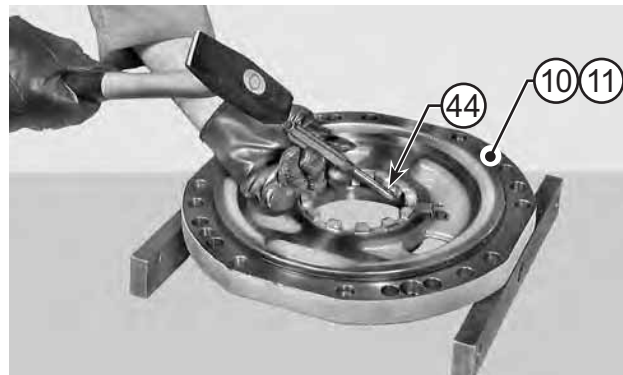

FIGURE 17: If bearings need replacing, remove the outer thrust blocks of bearings (44) from intermediate covers (10) and (11)



FIGURE 18: DISASSEMBLING THE BRAKE PISTON
Gently introduce low-pressure compressed air through the connection of the working brake line and eject the complete piston (22).

NOTE:

Replace seals (23) and (24) and anti-extrusion rings at each disassembly.



FIGURE 19: DISASSEMBLING THE DIFFERENTIAL GEAR
With a puller applied under coupling (25), remove bearing (44) and shoulder (26) for coupling (25).

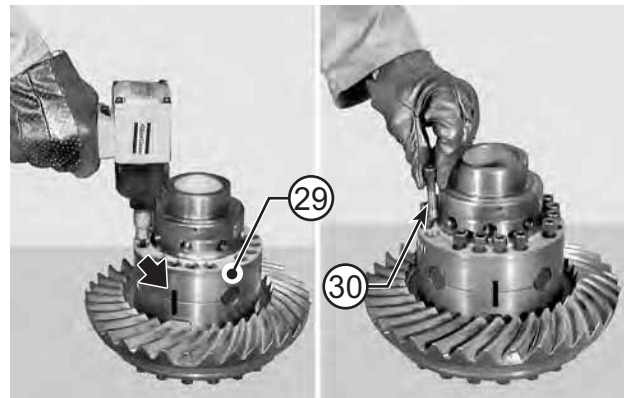

FIGURE 22: Make positional marks on the half-boxes of differential (29); loosen and remove joining screws (30).

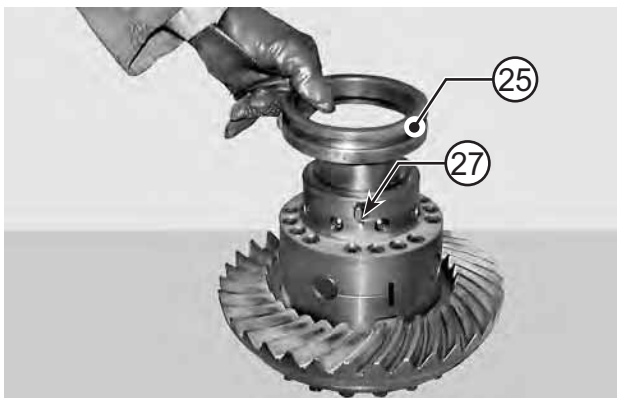

FIGURE 20: Remove coupling (25) and collect the drive balls (27).

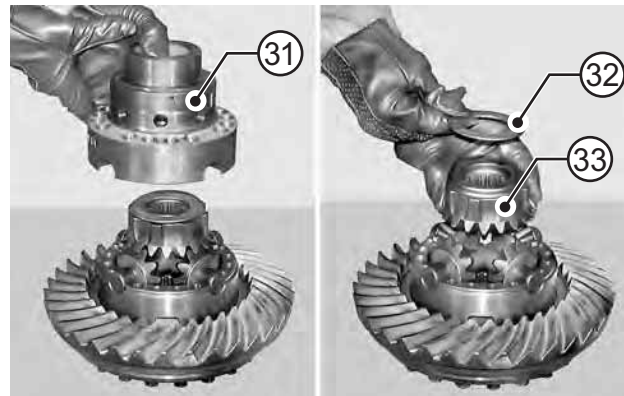

FIGURE 23: Remove upper half box (31), and then remove shoulder ring (32) and planetary gear (33). Complete differential disassembly procedure by following the instructions given in the first part of the manual (see DIFFERENTIAL UNIT p. 73).



FIGURE 21: Only if necessary, remove guide key (28) from coupling (25).

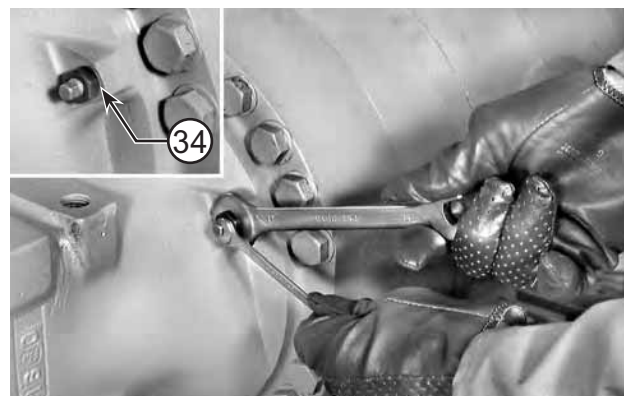

FIGURE 24: REPLACING THE BRAKE DISCS
Loosen and remove lock nuts (34) (qty. 3) and seal washers (35).

DISASSEMBLY

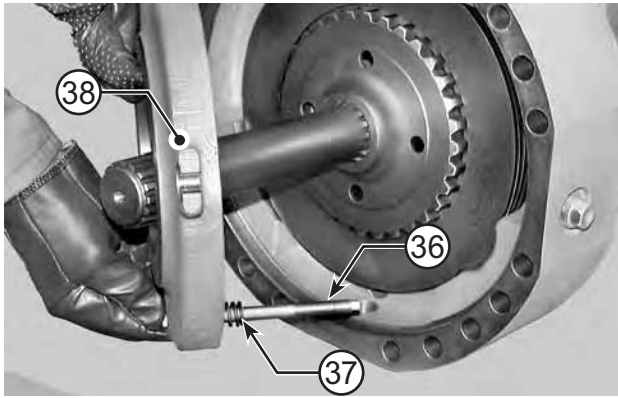

FIGURE 25: Remove screws (36), springs (37), and pressure plate (38).

Proceed by removing the brake discs.

(For details, see CHECKING WEAR AND REPLACING THE BRAKING DISCS p. 17 in the first part of the manual).

ASSEMBLY



FIGURE 26: IF DIFFERENTIAL HAS BEEN DISASSEMBLED Assemble the differential unit (29). For details, see DIFFERENTIAL UNIT p. 73 in the first part of the manual. Put the guide key (28) of coupling (25) in place.

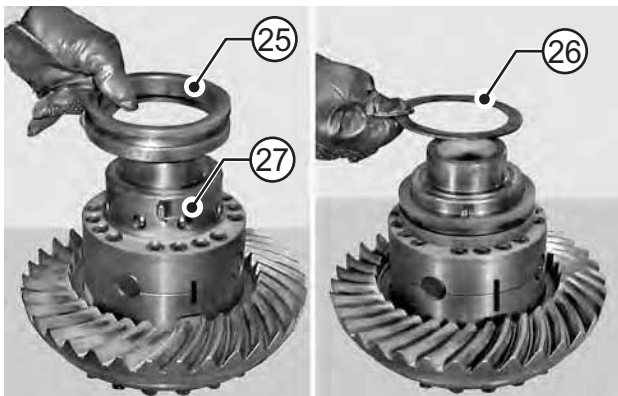

FIGURE 27: Grease the ball slots and fit in the balls (27), coupling (25), and shoulder (26).



FIGURE 28: Heat bearing (44) to approximately 194 °F [90 °C] and install on the differential.

NOTE:

Make sure the bearing is securely engaged.

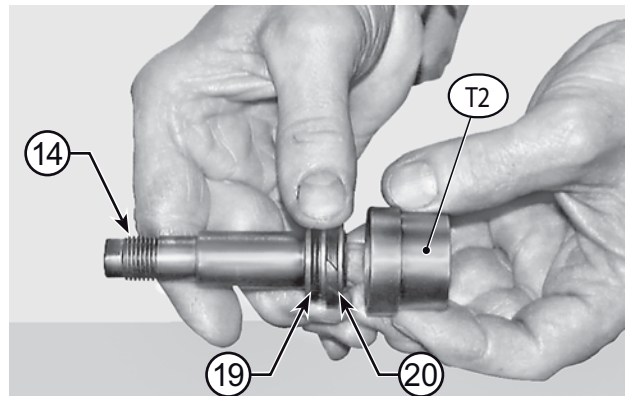

FIGURE 29: ASSEMBLING LOCK CONTROL
Fit o-ring (19) and guide ring (20) onto piston (14). Lubricate the seals and introduce the unit in tool T2 (See drawing T2 p. 109) .

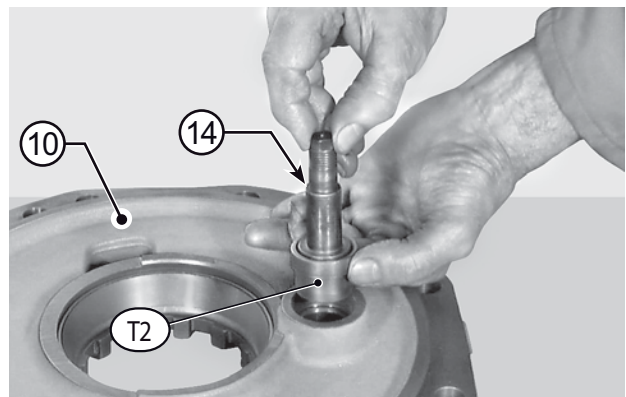

FIGURE 30: Place tool T2 (See drawing T2 p. 109) on the intermediate cover (10) and push piston (14) into its seat.



FIGURE 31: Fit spring (18) and ring nut (17) on piston (14). Tighten the ring nut by a few turns. Apply a coat of Loctite 242 to the ring nut and tighten to a maximum torque of 50 N·m.

ASSEMBLY

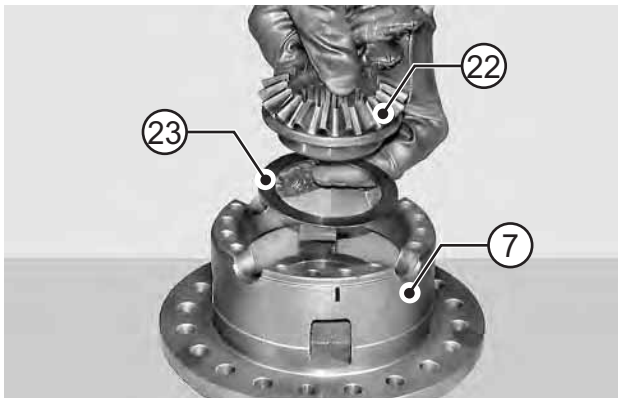

FIGURE 32: Fit selector fork (16) on piston (14) and make sure selector fork orientation is correct.

NOTE:

Microswitch activation cam "A" must face upwards.

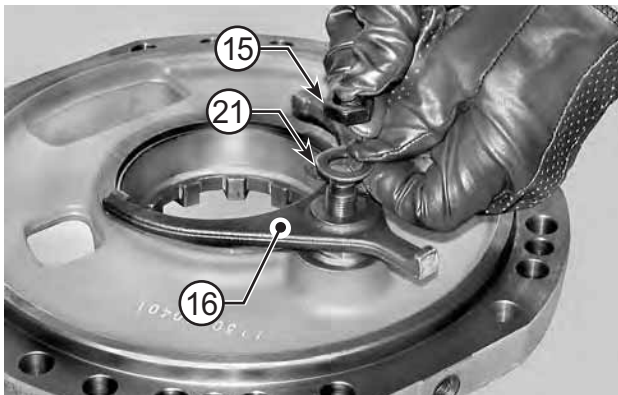

FIGURE 33: Secure selector fork (16) with washer (21) and nut (15).

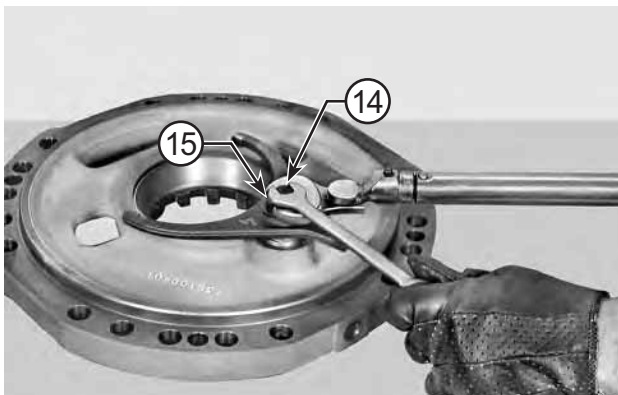

FIGURE 34: While holding piston (14) in position, tighten the nut (15) with a torque wrench to 225 - 230 N·m.

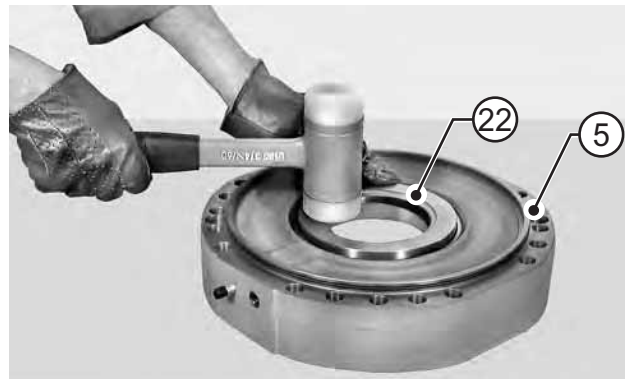

FIGURE 35: ASSEMBLING THE BRAKE PISTON
Fit o-rings (23, 24) and anti-extrusion rings (39) and (40) on piston (22).
Lubricate the seals and introduce piston (22) into cylinder (5).

NOTE:

Thoroughly check the position of anti-extrusion rings (39, 40).

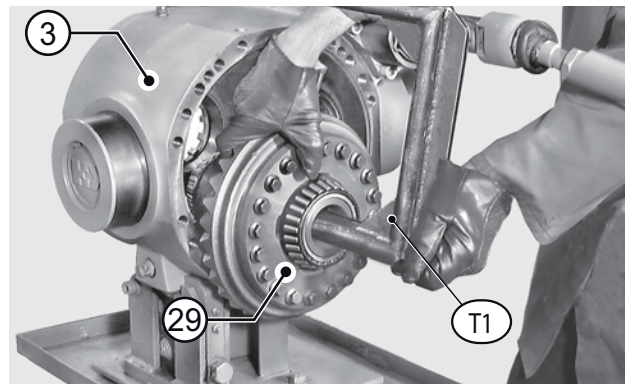

FIGURE 36: Using tool T1 (See drawing T1 p. 108), introduce the whole differential (3) into the main body (29).

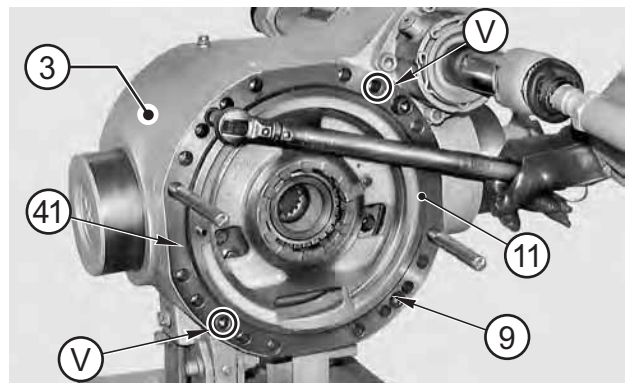

FIGURE 37: Tighten two safety studs in the main body (3) and install the intermediate cover (11).
Lock in position with screws "V" tightened to 130 - 143 N·m.

NOTE:

Check the condition of the o-ring (41).

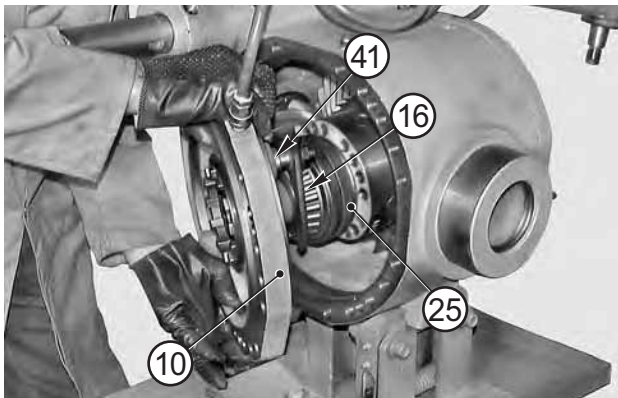

FIGURE 38: Introduce low-pressure compressed air through connection "B" and make sure that the lock control piston comes out at the end of stroke. Rotate the intermediate cover (10) to an angle of about 45°; engage the selector fork (16) in the lock control coupling (25).

NOTE:

Check the condition of the o-ring (41).

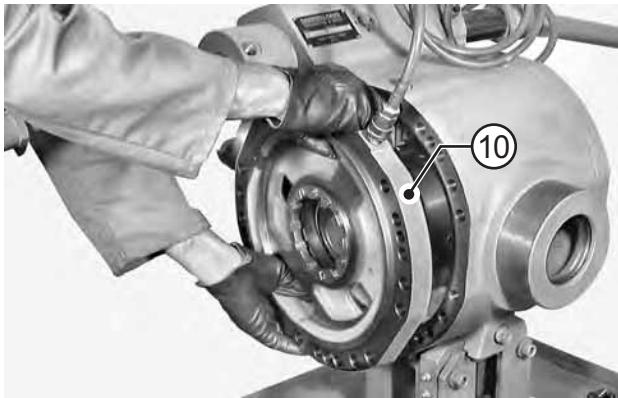

FIGURE 39: As you hold the selector fork in position (16), rotate the intermediate cover into its final position (10). To lock into position, tighten two safety studs "A" in two opposing holes.

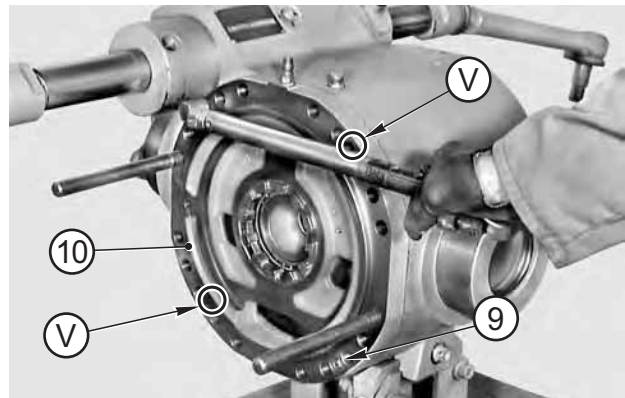

FIGURE 40: Clear any compressed air and finally move the intermediate cover (10) into its seat. Lock into position with nuts "V" tightened to matching torque of 130 - 143 N·m.

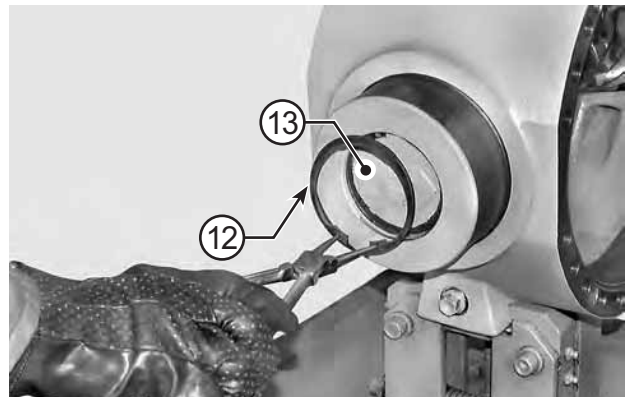

FIGURE 41: If necessary, adjust differential clearances. (See DIFFERENTIAL UNIT p. 73). Install the cap (13) and snap ring (12).

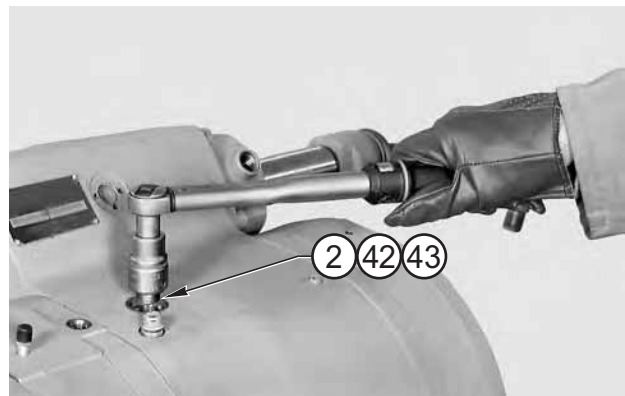

FIGURE 42: Fit the microswitch (2) complete with the o-ring (42) and the relative retainer ring (43). Install the arms. (See CHECKING WEAR AND REPLACING THE BRAKING DISCS p. 17).

SPECIAL TOOLS

SPECIAL TOOLS

T1

P/N: 2370

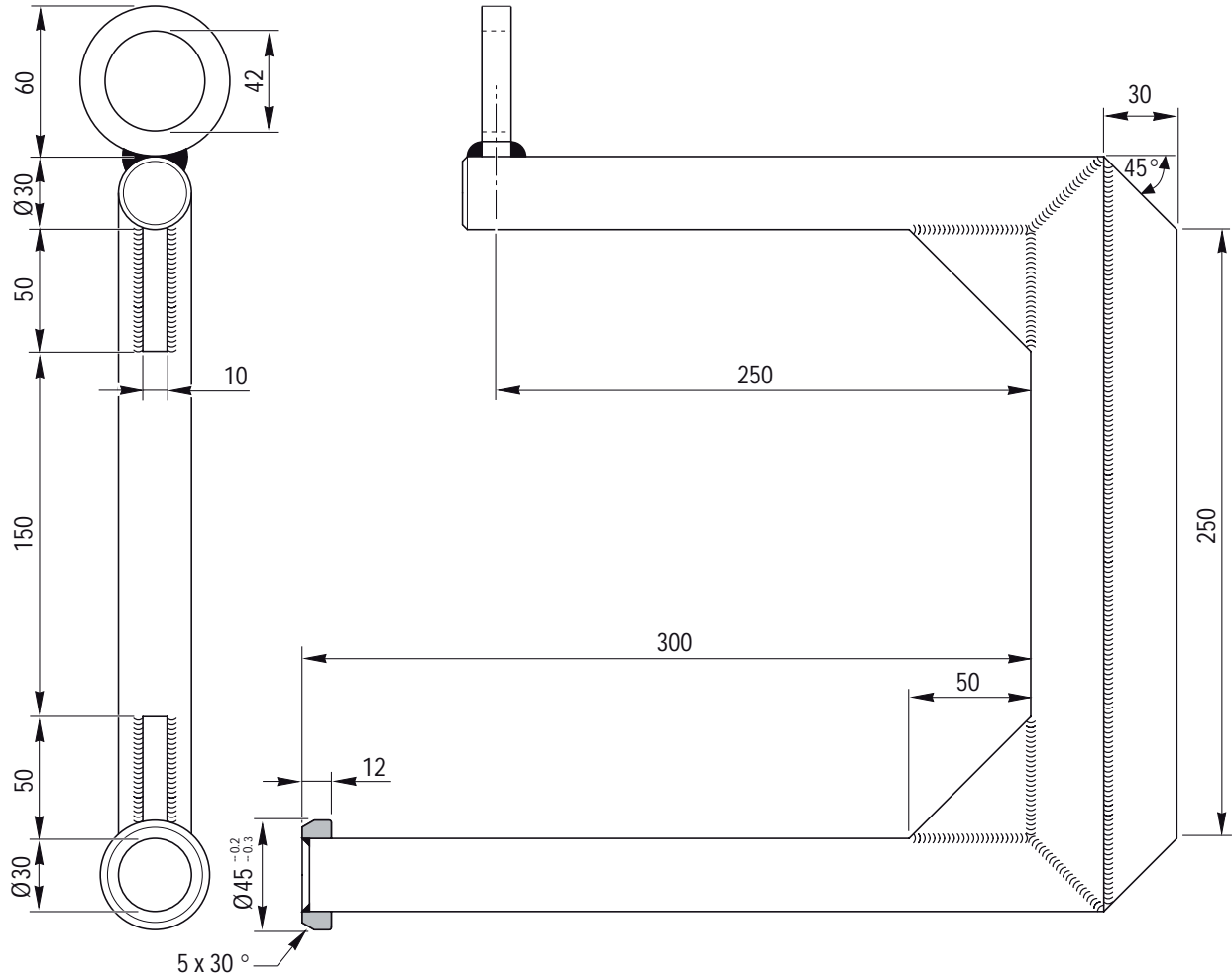

T2

P/N: 2376

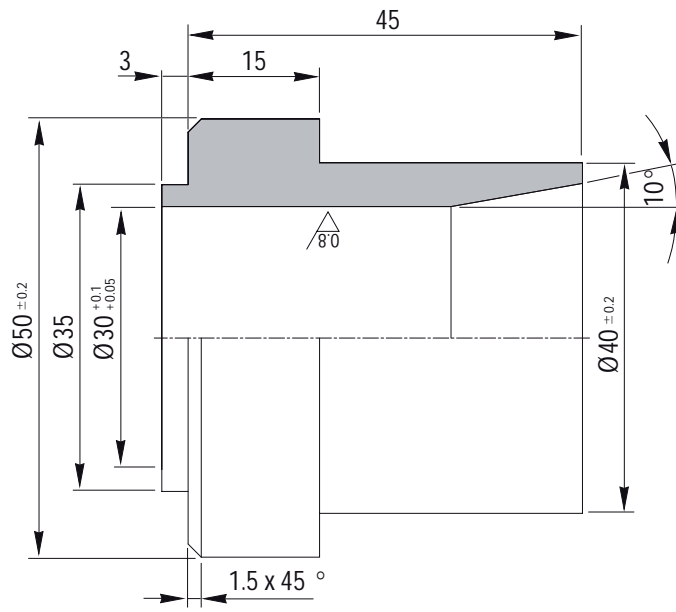

LIMITED SLIP DIFFERENTIAL UNIT 45%

EXPLODED VIEW

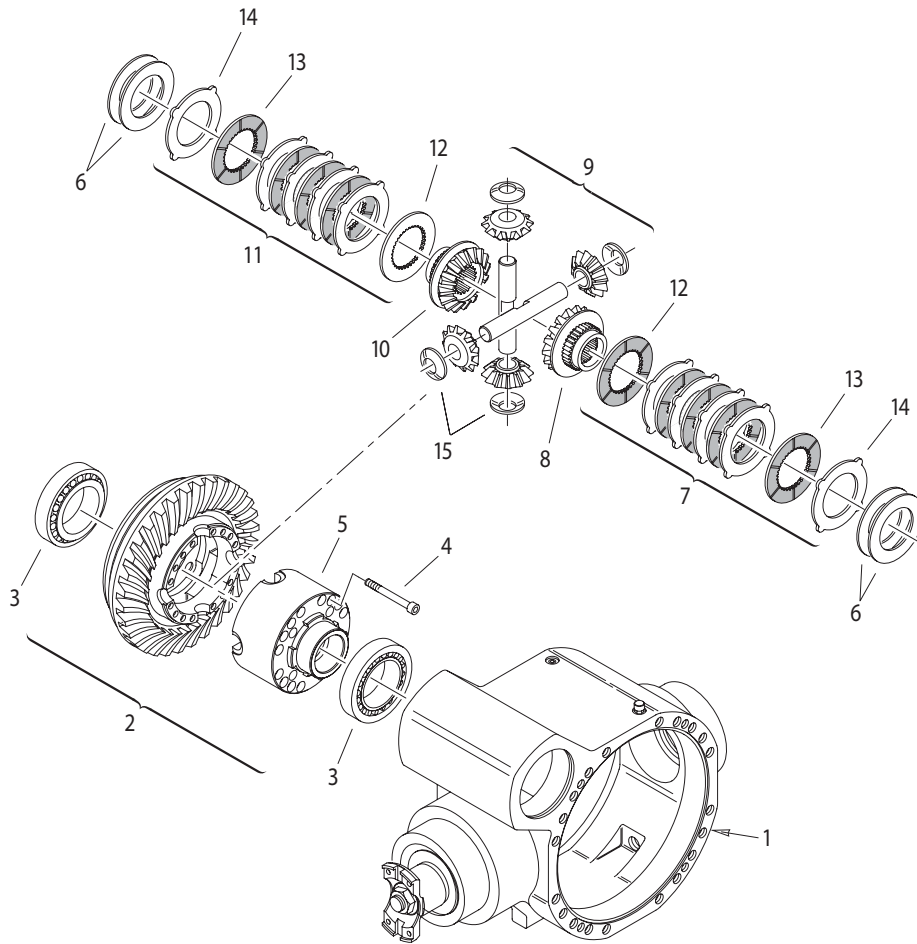

DISASSEMBLY

DISASSEMBLY

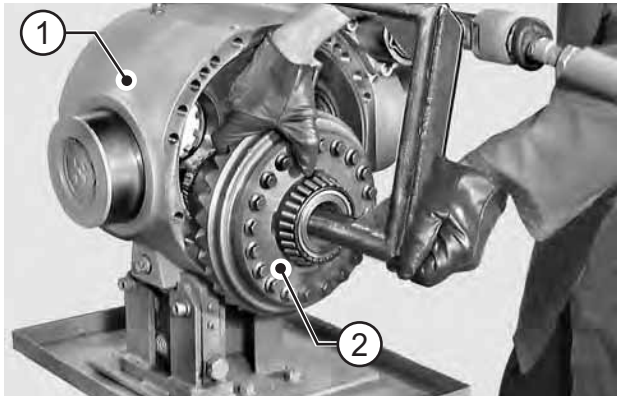

FIGURE 1: Remove the whole differential unit (2) from the main body (1).
(For details, see DIFFERENTIAL UNIT p. 73).

⚠CAUTION

The following section includes clutch replacement procedures only; for ring gear replacement, see DIFFERENTIAL UNIT p. 73.



FIGURE 2: Using a puller, remove bearing (3).

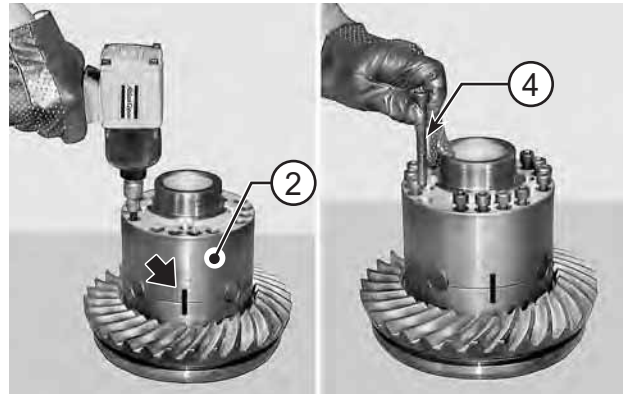

FIGURE 3: Make positional marks on the half boxes of the differential gear (2); loosen and remove joining screws (4).

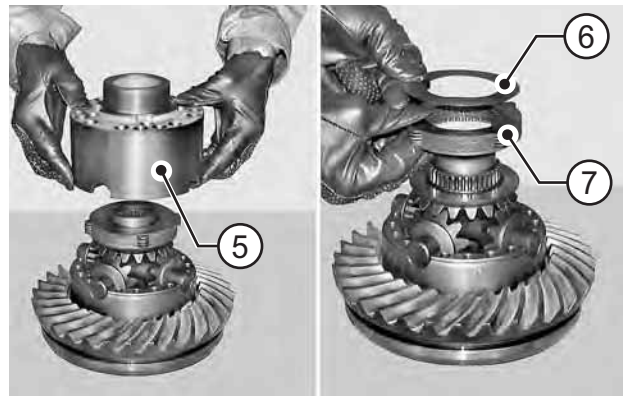

FIGURE 4: Remove the upper half box (5), shims (6), and clutch pack (7).

⚠CAUTION

If the clutch pack does not need replacing, avoid swapping discs position.

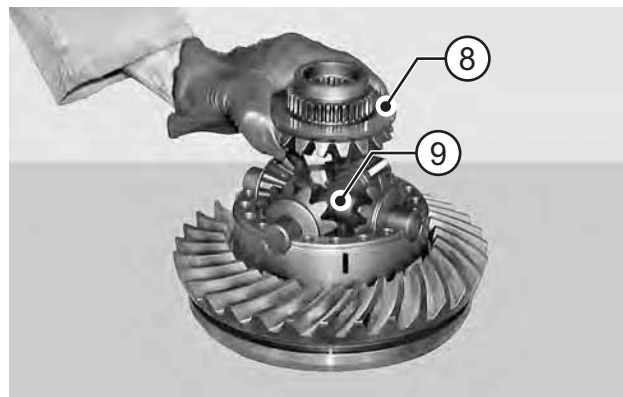

FIGURE 5: Remove the planetary gear (8) and planetary gear set (9).

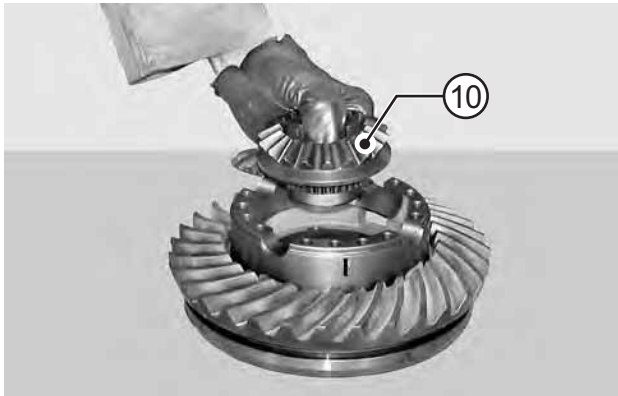

FIGURE 6: Remove the 2nd planetary gear (10).

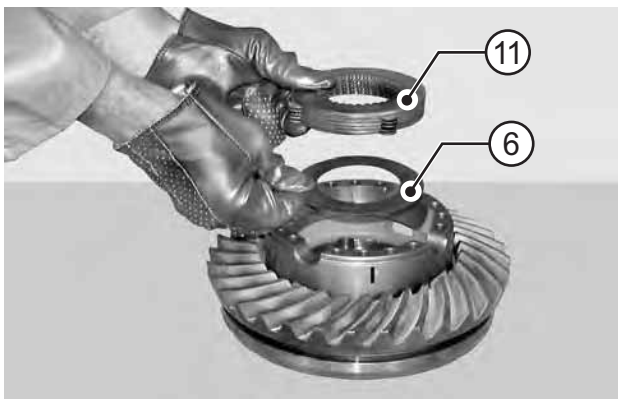

FIGURE 7: Remove the 2nd clutch pack (11) and shim set (6).

⚠ CAUTION

If the clutch pack does not need replacing, avoid swapping discs position.

ASSEMBLY

ASSEMBLY

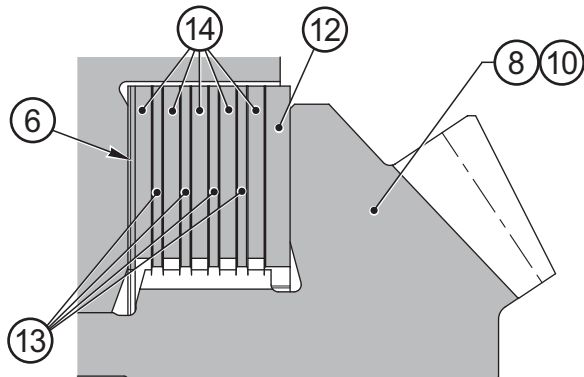

FIGURE 8: Only in case of clutch pack replacement, assemble the packs with increased shims (12), clutch discs (13), intermediate discs (14), and shims (6).

⚠ CAUTION

Add shims (6) until a total size of 17.6 ± 0.05 mm is obtained.

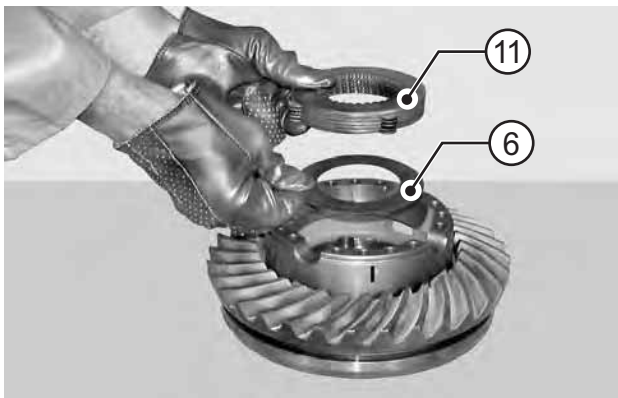

FIGURE 9: Fit shims (6) and clutch pack (11) sequentially.

⚠ CAUTION

When installing the increased shim, place shim so that it leans against the crown wheel (8, 10).



FIGURE 10: Install planetary gear (10).

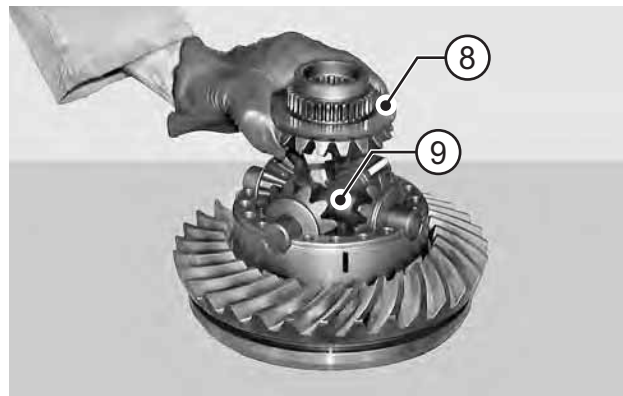

FIGURE 11: Fit the planetary gear set (9). Install second planetary gear (8).

📌 NOTE:

Make sure that spherical thrust washers (15) are present.

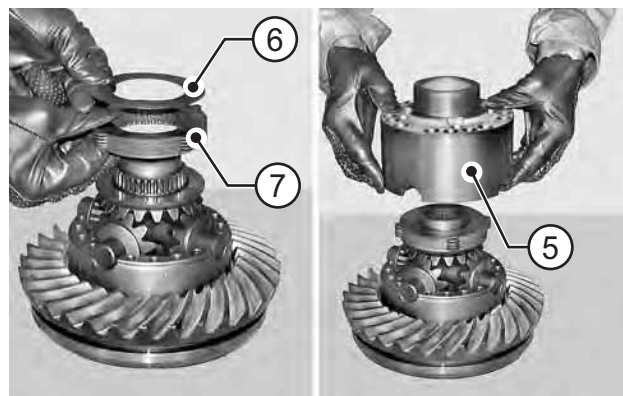

FIGURE 12: Fit increased shim (12), clutch pack (7), and shims (6) onto the planetary gear (8). Fit the upper half box (5) and make sure that the marks line up. Complete the assembling operation and install the differential unit following the procedures described in the first part of the manual under section DIFFERENTIAL UNIT p. 73.

© Copyright 2012 Dana Holding Corporation
All content is subject to copyright by Dana and may not be reproduced in whole or in part by any means, electronic or otherwise, without prior written approval.
THIS INFORMATION IS NOT INTENDED FOR SALE OR RESALE, AND THIS NOTICE MUST REMAIN ON ALL COPIES.

For product inquiries or support,
visit www.dana.com or call 419-887-6445
For other service publications,
visit www.SpicerParts.com/literature.asp
For online service parts ordering,
visit www.SpicerParts.com/order.asp



SPICER[®]
Off-Highway Products